

B-Nimis MC-Pi and BC-Pi Plus series

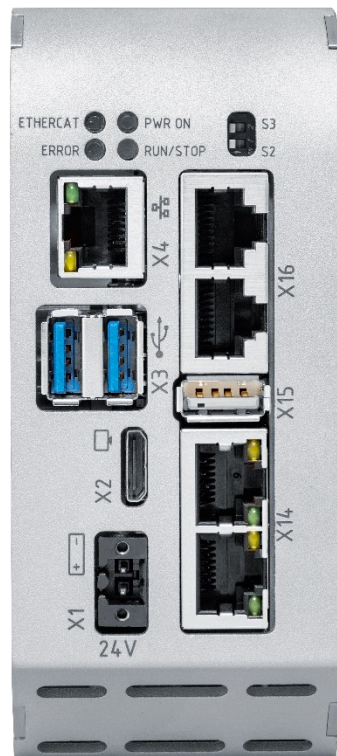

Copyright © Berghof Automation GmbH

Reproduction and duplication of this document and utilisation and communication of its content are prohibited without with our express permission. All rights reserved.

Infringements will result in compensation for damages.

Disclaimer

The content of this document has been checked for conformity with the hardware and software described. It is, however, impossible to rule out all discrepancies. As a result, we cannot be held responsible if the content is not fully compliant. The information in this document is checked regularly and any necessary corrections are included in subsequent editions. Suggestions for improvement are always welcome. Subject to technical modifications.

Trademarks

- CANtrol®// is a registered trademark of Berghof Automation GmbH.
- Microsoft®, Windows® and the Windows® logo are registered trademarks of Microsoft Corp. in the USA and other countries.
- EtherCAT® is a registered trademark and a patented technology, licensed by Beckhoff Automation GmbH, Germany.
- CiA® and CANopen® are registered community trademarks of CAN in Automation e. V.
- ARM® and Cortex® are registered trademarks of ARM Limited.
- PROFINET® is a registered trademark of PROFIBUS Nutzerorganisation e.V.
- Modbus® is a registered trademark of the Modbus-IDA organisation.
- Raspberry Pi is a registered trademark of the Raspberry Pi Foundation.

The rights of all companies and company names mentioned in this document as well as products and product names belong to the respective companies.

Notes about this handbook

This equipment handbook contains information which is specific to the product and valid at the time of printing.

This equipment handbook is only complete in conjunction with the product-related hardware and software manuals required for the specific application.

You can contact us at:

Berghof Automation GmbH

Arbachtalstrasse 26

72800 Eningen

Germany

T +49.7121.894-0

F +49.7121.894-100

Email: controls@berghof.com

www.berghof-automation.com

Berghof Automation GmbH is certified to DIN EN ISO 9001:2015.

Revision log

Version	Date	Description
1.0	23/02/2023	Preliminary version
1.1	05.04.2023	UL Relevant changes, BC-PI-Plus S04 added
1.2	06.09.2023	Supplement Password configuration, Cyber security
1.3	19.08.2024	Type plate description

Table of contents

1.	GENERAL INFORMATION	7
1.1.	Notes about this handbook	7
1.2.	Symbols and visual depictions	8
1.3.	Hazard categories and indications	9
1.4.	Qualified personnel	9
1.5.	Duty of care	10
1.6.	Intended use	11
1.7.	Transport and storage	12
1.8.	Unpacking	12
2.	SAFETY	13
2.1.	Safety-related systems	13
2.2.	Safety instructions	13
2.3.	Cybersecurity	14
3.	PRODUCT DESCRIPTION	15
3.1.	Overview	15
4.	TECHNICAL DATA	16
4.1.	B-Nimis BC-Pi Plus	16
4.2.	B-Nimis MC-Pi Plus	17
4.3.	Scope of delivery and accessories	18
4.4.	Product features	19
5.	ASSEMBLY	21
5.1.	Installation	21
6.	CONNECTION	23
6.1.	Power supply	23
	Connecting the power supply	24
	Properties	24
6.2.	Earthing	25
6.3.	Data connections	26
6.3.1.	Block diagram	26
6.3.2.	Network connection	27
6.3.3.	USB interface	28

6.3.4. EtherCAT	29
6.3.5. RS 485 / RS 232 interface	30
Signal interference and termination	31
GND connections	31
6.3.6. CAN interface	32
7. OPERATION	33
7.1. Switching on and off	33
7.2. Initial start-up of the network	34
7.2.1. MC-Pi	34
Starting-up via the web interface	34
7.2.2. BC-Pi	36
Standard start-up	36
Start-up via SSH terminal	36
7.3. Operation	38
7.3.1. Status indicators	38
7.3.2. Real-time clock with battery back-up	40
7.3.3. SD card	40
7.3.4. Start/Stop reset button	41
7.4. Troubleshooting	42
7.4.1. No network connection	42
7.4.2. In error stop mode	42
7.4.3. Unknown IP address	42
8. SERVICING / MAINTENANCE	43
9. DISASSEMBLY	44
10. DISPOSAL	45
11. INFORMATION AND OPTIONS	46
11.1. Type plate	46
11.2. Device variants and Memory configuration levels	47
11.3. Options and extensions	47
12. STANDARDS AND CERTIFICATES	49
12.1. Declaration of Conformity/Technical data	49
13. CUSTOMER SERVICES / ADDRESSES	50
13.1. Customer services	50
13.2. Repair service	50
13.3. Addresses	51
14. APPENDIX	52

14.1. Notes on copyright and the software licence52
14.2. List of figures53

1. General information

This user handbook is intended for use by qualified personnel and contains information on the assembly, installation, start-up and maintenance of the device.

1.1. Notes about this handbook

This user handbook is a component of the product and applies to the following devices:

- B-Nimis MC-Pi-Plus S01 S-01030303-0100
- B-Nimis MC-Pi-Plus S02 S-01030303-0200

- B-Nimis BC-Pi Plus S01 S-01080103-0100
- B-Nimis BC-Pi Plus S02 S-01080103-0200
- B-Nimis BC-Pi Plus S03 S-01080103-0300
- B-Nimis BC-Pi Plus S04 S-01080103-0400

It contains information on the following topics:

- Areas of application
- Safety
- Mechanical design
- Electrical design
- Connections
- Start-up
- Servicing and maintenance
- Decommissioning
- Disposal

- ▶ Keep this user handbook available alongside the product at all times.

1.2. Symbols and visual depictions

The following symbols and visual depictions are used in this user handbook:

Symbol	Meaning
→ ...	List entry
▶ ...	Individual instruction or list of instructions which can be carried out in any order.
1. ... 2. ...	List of instructions which must be carried out in the order given.
	Additional product information

Structure of the warnings:

 WARNING	
Optional:	Type and source of the danger
More symbols	Brief description and consequences
	▶ Preventive measures

1.3. Hazard categories and indications

The following indications are used for warning messages that must be observed to ensure your personal safety and avoid any damage to property.

The indications have the following meanings:

DANGER

Serious injury or death

Failure to observe the safety measures will result in death or serious injury.

- ▶ Take preventive measures.

WARNING

Possible serious injury or death

Failure to observe the safety measures may result in death or serious injury.

- ▶ Take preventive measures.

CAUTION

Possible minor injuries

Failure to observe the safety measures may result in minor injuries.

- ▶ Take preventive measures.

NOTICE

Possible damage to property

Failure to observe the safety measures may result in damage to property.

- ▶ Take preventive measures.

1.4. Qualified personnel

The installation, start-up and maintenance of the machine must be carried out by qualified personnel.

For the purposes of this documentation and the safety instructions contained therein, “qualified personnel” means trained staff with the authorisation to assemble, install, start up, earth and identify devices, systems and electrical circuits in accordance with the standards set in safety engineering and who are familiar with safety concepts in automation engineering.

1.5. Duty of care

The user or processor (OEM) must ensure the following:

- The device must only be used for its intended purpose.
- The device must only be used in a perfect, fully functional condition.
- The user handbook must always be kept legible and fully available.
- Only sufficiently qualified and authorised personnel carry out assembly, installation, start-up and maintenance of the device.
- These authorised personnel must receive regular training in all relevant questions of occupational health and safety and environmental protection and must be familiar with the contents of this user handbook, particularly the sections containing safety instructions.
- Any markings or identification labels and safety and warning signs on the device must not be removed and must be kept legible at all times.
- The national and international regulations regarding the operation of machinery and installations where the device is being used must be observed.
- The user must always be kept abreast of any current relevant information regarding the device and its use or operation.
- The user is responsible for coordinating the use of the safety-related control components with the responsible authority and for adhering to its specifications.

1.6. Intended use

The device is a component of a modular automation system for industrial control applications in the medium to high performance range.

The automation system is designed for use in overvoltage category I (IEC 364-4-443) for the control and regulation of machinery and industrial processes in low-voltage installations in accordance with the following basic conditions.

- Maximum rated supply voltage of 1000 V AC (50/60 Hz) or 1500 V DC
- For use in an environment with max. category 2 level of pollution (EN 60950)
- For use in a maximum altitude of 2,000 m a.s.l.
- For indoor use in areas not exposed to direct UV radiation
- Max. ambient temperature inside and outside the control cabinet according to the technical specifications (see Technical Data”).

Correct and safe operation of the automation system requires qualified project planning, proper transport, storage, installation and use as well as careful maintenance.

The automation system may only be used within the scope of the information and applications specified in this documentation and associated user handbooks.

The automation system must only be used as follows:

- As intended
 - In technically perfect condition
 - Without unauthorised modifications
 - By qualified users only
-
- ▶ Observe the rules of the employers' liability insurance association, the German Technical Inspection Association (TÜV), the Association of German Electrical Engineers (VDE) or relevant national regulations.

The device is intended for installation in control cabinets in industrial machines and systems in indoor areas.

- ▶ For operation, refer to the applicable ambient conditions

1.7. Transport and storage

The unit is sensitive to shocks, strong vibrations, humidity and extreme temperatures.

Transport and storage

- ▶ Protect the unit from strong mechanical stresses during transport.
- ▶ Always transport the unit in its original packaging.
- ▶ Observe the environmental conditions applicable to storage.
- ▶ Protect the device from precipitation and moisture.

Operation

- ▶ If the device has been stored or transported in cold weather or under conditions of large fluctuations in temperature, do not start to operate it until it has acclimatised to room temperature for the place in which it is used.
- ▶ Wait at least 12 hours after it has reached room temperature before operating the device.

1.8. Unpacking

When receiving the unit, make sure that the delivery is undamaged and complete.

- ▶ Check the packaging for external damage.
- ▶ If there is serious damage to the packaging or if damage to the contents is apparent: Do not open the packaging any further and inform the carrier and your supplier immediately.
- ▶ Remove the packaging and keep it for re-transport.
- ▶ Check the contents for visible transport damage.
- ▶ Check the contents against the order for completeness and be sure to retain all documentation supplied. The documentation supplied contains important information about the unit and is part of the product.
- ▶ If you notice transport damage or discrepancies between the order and the delivered contents: Inform the supplier immediately.

2. Safety

2.1. Safety-related systems

The use of PLC controls in safety-related systems requires specific measures. If a PLC controller is to be used in a safety-related system, the user must be given comprehensive advice by the PLC manufacturer in addition to any available standards or guidelines regarding safety installations.

- ▶ Before starting work on the devices, switch off all power supplies, including those of connected peripherals.
- ▶ Keep all ventilation openings unobstructed.

The failure of certain components in an electronic control system may result in uncontrolled and/or unpredictable operational behaviour.

- ▶ All types of failure must be considered at the system level and the associated preventative measures identified.
- ▶ If necessary, request information from your automation system provider.

2.2. Safety instructions

CAUTION

Possible minor injuries and/or burning of the surface of the skin

Non-compliance with the safety features may result in minor injuries / burning of the surface of the skin

The device may only be operated only when it is in good working order. Exposed sharp edges or broken glass pose an injury risk.

- ▶ If you detect damage to the front glass of the device, stop operating the device and immediately disconnect it from the power supply.

The device may heat up during operation, especially in hot environments, because of the passive cooling mechanism of the electronics inside. The surface temperature may be high enough to cause burning if there is prolonged contact with the human skin.

- ▶ If possible, avoid touching the rear panel of the device during operation.
- ▶ If you plan to work on e.g. the installation or cabling of the device, first shut it down by disconnecting the power supply and let it cool down for a while.
- ▶ It is recommended to wear personal protective equipment, e.g. protective gloves when handling the warmed up device.

Working on the device

Do not start work on the device until all necessary safety precautions have been taken. Take precautions to avoid unforeseeable functional events and movements of the system.

- ▶ Bring the system into a safe state.
- ▶ Switch the system and the device off.
- ▶ Secure the system against being switched on again.

- ▶ Disconnect the device from the system.

Do not open the device housing.

- ▶ If it is necessary to work on internal parts of the device, contact the manufacturer (see “Customer services / addresses”).

2.3. Cybersecurity

- ▶ Never place the control unit on the Internet without additional protection mechanisms, this product is not designed for this purpose
- ▶ Change the default passwords specified on delivery
- ▶ Always use an upstream external firewall to prevent access from the outside to the inside.
- ▶ Use the security mechanisms of VPN server portals (e.g. IXON) to which the controller can actively connect via VPN or comparable mechanisms

- ▶ Always use https instead of http
- ▶ Deactivate unnecessary services such as (FTP/SSH/Webserver)

Contact person for cybersecurity of Berghof:

Berghof-Product-Security Incident Response Team

psirt.automation@berghof.com

3. Product description

3.1. Overview

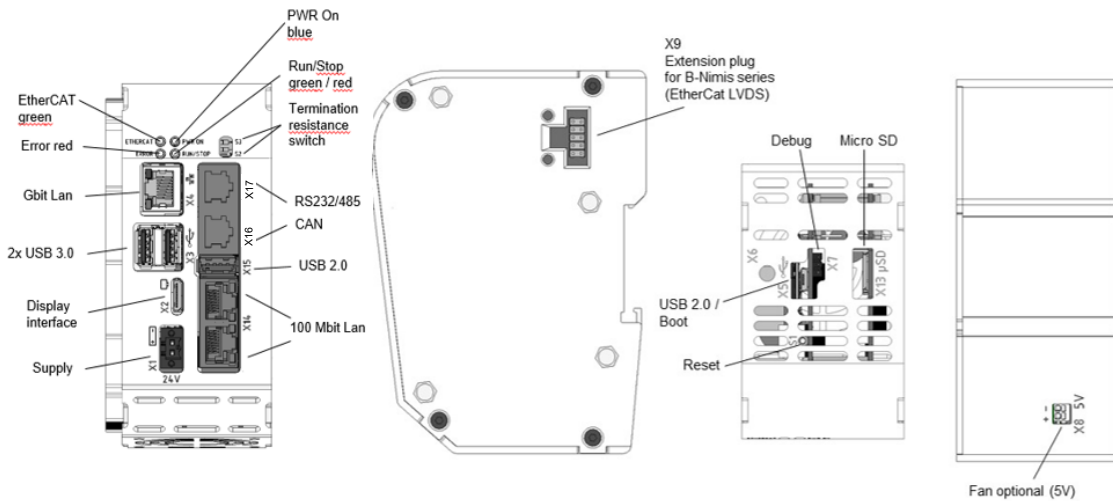

Fig.: 1 Overview of B-Nimis MC-Pi Prime and BC-Pi Prime

Pos.	Description	Pos.	Description
X1	Power Supply	X13	Micro SD
X2	Display Interface	X14	2x 100 Mbit LAN [ET2]
X3	2 x USB 3.0	X15	USB 2.0
X4	Gbit LAN [ETH0] ¹	X16	CAN [CAN0]
X5	USB 2.0 / Boot	X17	RS232/485 [COM1]
X6	Connector for antenna	S1	Reset
X7	Debug	S2	CAN Terminating resistor switch
X8	Fan (option)	S3	RS485 Terminating resistor switch
X9	EtherCAT LVDS [ETH1]		

¹ Designations in []: CODESYS-designations of the connections

4. Technical Data

4.1. B-Nimis BC-Pi Plus

B-Nimis BC-Pi Pro	Version			
Description	BC-Pi Plus S01	BC-Pi Plus S02	BC-Pi Plus S03	BC-Pi Plus S04
Order Number	S-01080103-0100	S-01080103-0200	S-01080103-0300	S-01080103-0400
Dimensions/Weight	33 x 122 x 89 (W x H x D[mm]) / 0.5 Kg			
Assembly	DIN Rail NS 35/7,5 EN 60715			
Certification	CE , UKCA, FCC/ISED, UL			
Development Tool	Raspberry Pi OS			
	Compatible with Raspberry Pi-Community			
CPU	BCM 2711, 1,5 GHz Quadcore			
RAM/Flash	1 GB / 8 GB	2 GB / 8 GB	4 GB / 32 GB	8 GB / 32 GB
Communication	3 x RJ45 Ethernet: 1x 10/100/1000 Base-T; 1x 10/100 Base-T 2-Port Switch			
	1x RS232/485 Switchable			
	1x CAN			
	1x EtherCAT LVDS for expansion modules of the B-Nimis IO series			
	2x Host USB 3.2 Gen 1, 1x Host USB 2.0 / USB connector type A			
	WLAN / Bluetooth (option H400)			
Protocol	Standard: EtherCAT Master and more from third-party providers			
Additional Features	External monitor via digital display interface			
	1x µSD (SDXC)			
	1 x 2 Pin for optional fan (5VDC, max. 100 mA)			
	1 x Real Time Clock, 30 days buffer			
	Extended heat sink (option)			
Supply characteristics	+24 V DC (-20% / +25%) SELV voltage supply with reverse polarity protection. Max. AC ripple 5%			
	Current consumption typ. 0.3A, max. 2A at +24 VDC			
	Galvanic Isolation for RS 485/232 and CAN			
Environmental conditions	Ambient temperature:			
	- Transport/storage: -20 °C bis +70 °C			
	- Operation: Without heat sink and without fan -20 °C bis 40 °C, with heat sink only -20 °C bis 45 °C, with heat sink and fan -20 °C bis 55 °C			
	Relative humidity: max. 85%, non condensing			
	Protection class/ rating: III / IP20 DIN EN 60068-2-6 (2008-10): Oscillations, sinusoidal DIN EN 60068-2-27 (2010-02): Mechanical shock			
Emitted interference	IEC 61000-6-3:2021-03, Residential limit; EN 55032: 2015; FCC Parts 15.107, 15.109 Class B; ICES 003 Sections 3.2.1, 3.2.2, 3.2.3 Class B			

Immunity	IEC 61000-6-2:2019-02, industrial areas
Insulation re- sistance	SELV (Uw < 30 V) according to 61131-2; 500 VDC Testing Voltage

4.2. B-Nimis MC-Pi Plus

B-Nimis MC-Pi Plus	Version	
Description	MC Pi-Plus S01	MC Pi-Plus S02
Order Number	S-01030303-0100	S-01030303-0200
Dimensions/Weight	33 x 122 x 89 (W x H x D[mm]) / 0,5 Kg	
Assembly	Din Rail NS 35/7,5 EN 60715	
Certification	CE, UKCA, FCC/ISED, UL	
Development Tooling	CODESYS V3 (IEC61131-3)	
CPU	BCM2711, 1,5 GHz Quad Core	
RAM/Flash/Retain	1 GB RAM / 8 GB Flash 100 kB Retain	2 GB RAM / 8 GB Flash 100 kB Retain
Communication	3 x RJ45 Ethernet: 1x 10/100/1000 Base-T; 1x 10/100 Base-T 2-Port Switch	
	1x RS232/485 Switchable	
	1x CAN	
	1x EtherCAT LVDS	
	2x Host USB 3.2 Gen 1, 1x Host USB 2.0 / USB connector type A	
Protocol	WLAN / Bluetooth (option H400)	
	Standard: EtherCAT Master, CANopen Master, TCP/IP, NTP, FTP Option: Modbus, BACnet, Profinet, Ethernet/IP, SNMP, KNX, OPCuA, IoT, and others	
Visualization	WebVisu (WebServer, HTML5) using digital display interface (integrated web-browser) or external browser	
Additional Features	External monitor via digital display interface	
	1x μ SD (SDXC)	
	1 x 2 Pin connector for optional fan (5VDC, max. 100mA)	
	1 x Real Time Clock, 30 days buffer	
Supply characteristics	Additional expansions available via B-Nimis MC-IO EtherCAT expansion modules	
	+24 V DC (-20% / +25%) SELV voltage supply with reverse polarity protection. Max. AC ripple 5%	
	Current consumption typ. 0.3A, max. 2A at +24 VDC	
Environmental conditions	Galvanic isolation for RS 485/232 and CAN	
	Ambient temperature:	
	- Transport/storage: -20 °C to +70 °C	
	- Operation: Without heat sink and fan -20 °C to 40 °C, with heat sink only -20 °C to 45 °C, with heat sink and fan -20 °C to 55 °C	
	Relative humidity: max. 85%, non-condensing	
Protection class / rating: III / IP20		
DIN EN 60068-2-6 (2008-10): Oscillations, sinusoidal		
DIN EN 60068-2-27 (2010-02): Mechanical shock		

Emitted interference	IEC 61000-6-3:2021-03, Residential limit; EN 55032: 2015; FCC Parts 15.107, 15.109 Class B; ICES 003 Sections 3.2.1, 3.2.2, 3.2.3 Class B
Immunity	IEC 61000-6-2:2019-02, industrial areas
Insulation resistance	SELV (Uw < 30 V) acc to EN 61131-2; 500 VDC Testing Voltage

4.3. Scope of delivery and accessories

Scope of delivery:

Consists of the corresponding B-Nimis MC-Pi or BC-Pi control module and ordered accessories.

Accessories

The following accessories can be ordered directly as an option or separately via their respective order number:

Plug kit MC-Pi & BC-Pi:

plug kit with 1 x 2-pin power plug

Order option: H001

Order number: S-02020201-1000

Additional accessories

→ **Antenna extension cable**

Order number: S-02050401-0200

→ **Spar antenna WIFI/Bluetooth**

Order number: S-02050401-0100

→ **Fan**

Order Option H003

50mm 5V Fan for BC/MC-Pi Plus Order Number: S-02050501-0200

→ **Heat Sink:**

Order Option: H002

→ **Micro SD card**

Order Option 2 GB: H200

Order Option 16 GB: H201

4.4. Product features

The B-Nimis MC-Pi is a CODESYS PLC controller with a wide range of data interfaces. The B-Nimis BC-Pi is a Raspberry Pi OS-based mini PC with expansion options for EtherCAT modules of the B-Nimis MC-I/O series.

Mounting

The MC-Pi or BC-Pi is designed for control cabinet installation on a DIN mounting rail in harsh industrial environments.

Processor

The unit has a 1.5 GHz Broadcom BCM2711, Quad core Cortex-A72 (ARM v8) 64-bit SoC

Ethernet

The device has an Ethernet interface with 10/100/1000 Mbit/s. Furthermore, there is an additional 2-port 10/100 Mbit/s switch available. These interfaces support the TCP/IP and UDP/IP protocols which enable a very flexible connection to visualisation software, to higher-level control units or to the IT infrastructure.

EtherCAT

An EtherCAT extension interface with a 10-pin connection is available on the side. This interface is compatible with Berghof modules of the MC-I/O or E-I/O series.

USB

The USB 3.2 Gen 1 and USB 2.0 host interface is a widely used peripheral interface. This enables simple data exchange or expansion with compatible USB devices.



USB sticks with FAT/FAT32/exFAT/ext3/ext4 formatting are supported.

For support of other types of USB devices, please contact our technical support.

Real-time clock

A maintenance-free real-time clock with a supercapacitor back-up can be set to the current time via software interface. The back-up time is 30 days.

CAN interface

The device has a standard CAN interface that can be used to transfer data at speeds up to 1 Mbit/s.

Serial interface

The device has a combined serial interface (1x RS-485 or 1x RS-232).

SD card

The MC- and BC-Pi-Plus are equipped with 1 x μ SD card slot, e.g., for data downloads.

Display interface

The display interface is compatible with the HDMI 2.0 standard. Picture transmissions up to 4Kp60 are possible here, if supported by the display. For connection, a mini-HDMI cable is required that supports at least the HDMI 1.4 standard, with a corresponding connection for the connected monitor.

Visualisation

CODESYS web visualisation is included with the MC-Pi. With the Berghof B-Primis ET terminals, you have an easy-to-use display available.

5. Assembly

5.1. Installation

B-Nimis MC or BC-Pi modules are intended for installation on mounting rails (according to DIN EN 60715, 35 x 7.5 mm).

- Guide the device from below towards the mounting rail as shown in the image so that the metal spring snaps into place between the mounting rail and the mounting surface.
- Press the module at the top against the mounting wall until it snaps into place.

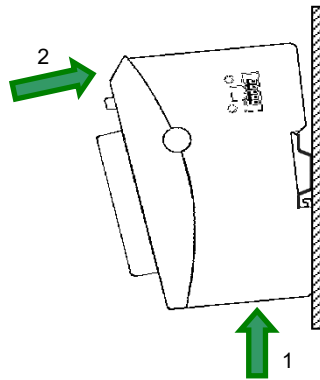

Fig.: 2 Installing the B-Nimis MC-Pi & BC-Pi

NOTICE

There must be at least 100 mm clearance above and below the MC-Pi & BC-Pi.

This guarantees the necessary convection cooling for the device. The mounting plate must be made of metal to ensure heat conduction.

Connecting two modules

After snapping the first module onto the rail, snap on the second module about 1 cm away, to the right of the first module. Push the second module along the rail towards the first module until the release latch snaps into place.

Disconnecting two modules

Push down the release latch (see figure) of the module that you wish to disconnect from the module to the left of it. Push both modules away from one another until they are about 1 cm apart.

- Push the module up and against the metal spring on the lower end of the rail guide. Press the module at the top against the mounting wall until it snaps into place.
- Turn the module forwards away from the mounting rail as shown in the illustration.
- Pull the module down off the mounting rail.

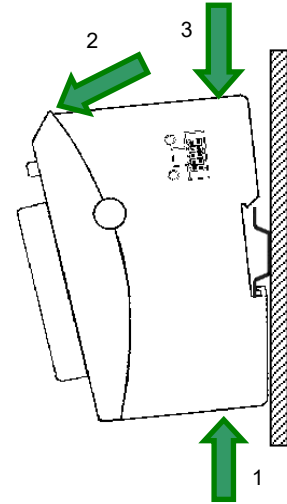

Fig.: 3 Disconnecting the B-Nimis MC-Pi & BC-Pi

6. Connection

WARNING

Uncontrolled and unpredictable operational behaviour!

The failure of certain components in electronic control systems may result in uncontrolled and unpredictable operational behaviour.

- ▶ All types of failure and the associated fuse systems should be considered at system level.
- ▶ Follow the automation system manufacturer's instructions.

6.1. Power supply

The device is powered by an external 24 V DC power supply.

- ▶ Before plugging in the device, make sure that the external power supply meets the required specifications (type K to DIN EN 61131-2).

External power supply (24 V DC)

Supply voltage	24 V DC SELV (-20% and +25%)
AC voltage component	Max. 5%; the DC voltage level must not fall below 19,2 V.

Internal power supply

A power supply for the system electronics for an input voltage of 24 V DC (-20% / +25%) is integrated into the device. The power supply unit has built-in reverse polarity protection and surge current protection.

The supply line and the power supply unit must be protected by an external short-circuit and over-load protection with a tripping current of max. 5 A.

Installation

- ▶ All connections and lines must be implemented in such a way that no faults are caused by inductive and capacitive interference in the controller.
- ▶ The supply lines must have sufficient dielectric strength and current capacity.
- ▶ Shielded cables must be used for communication lines.
- ▶ Connect the device to the power supply

Connecting the power supply

CAUTION

Live parts!

- ▶ Before starting any work on the device, switch off all power supplies, including those of connected peripherals.

B-Nimis MC-Pi and BC-Pi

- ▶ Connect the power supply to the plug according to the following table.

Power supply plug		
Connector	Pin	Function
	1	L+ external power supply 24 V DC (-20% / +25%)
	2	L- external power supply GND

The following counterparts have been tested for the SL-SMT 3.5 plug-in connector (Weidmueller), and may be used with the device:

→ BLF 3.50/02/180F SN BK BX

Properties

- Wire connection cross section AWG Min/Max: AWG26/AWG16
- Wire temperature stability: $\geq 120^{\circ}\text{C}$
- Contact material Cu/Cu alloy
- Tightening torque Min/Max: 0,15 Nm/0,2 Nm

NOTICE

Use Copper Conductors Only for the power supply!

6.2. Earthing

The MC-Pi and BC-Pi must be grounded. For this purpose, the metal housing must be connected to a functional earth.

The functional earth is used to dissipate RF currents and is of great importance to the module's immunity to interference. RF interference is conducted from the electronic circuit board to the metal housing. The metal housing now requires a suitable connection to a functional earth.

You must ensure that

- the module housing has a good conductive connection to the top-hat rail,
- the top-hat rail has a good conductive connection to the control cabinet,
- the control cabinet has a good earthing.

In special cases, the earth wire may be attached straight to the module.

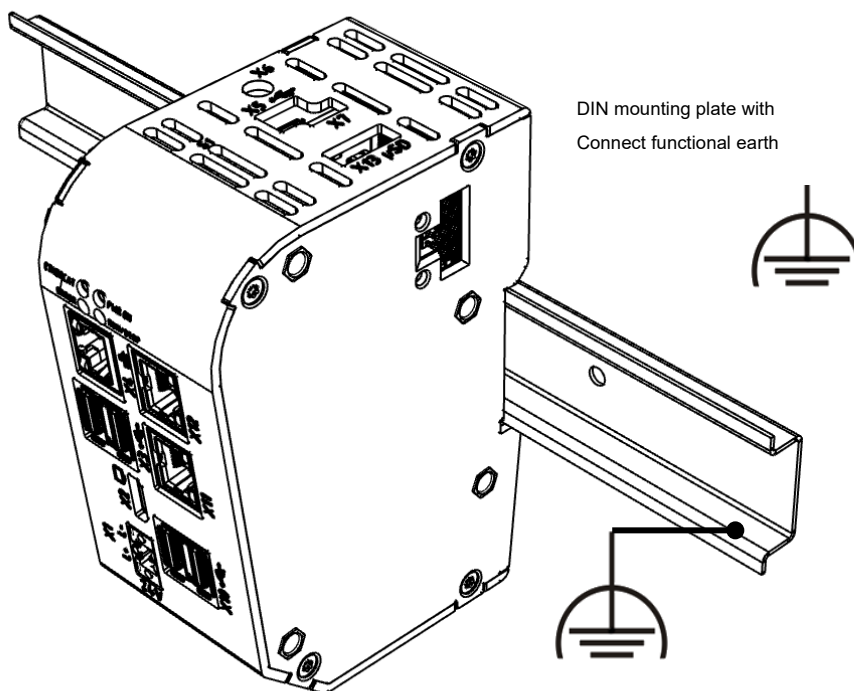

Fig.: 4 Earthing

NOTICE

Earth wires should be short and have a large surface area (copper braiding).

You can find information, for example, at [http://de.wikipedia.org/wiki/Masse_\(Electronics\)](http://de.wikipedia.org/wiki/Masse_(Electronics)).

6.3. Data connections

6.3.1. Block diagram

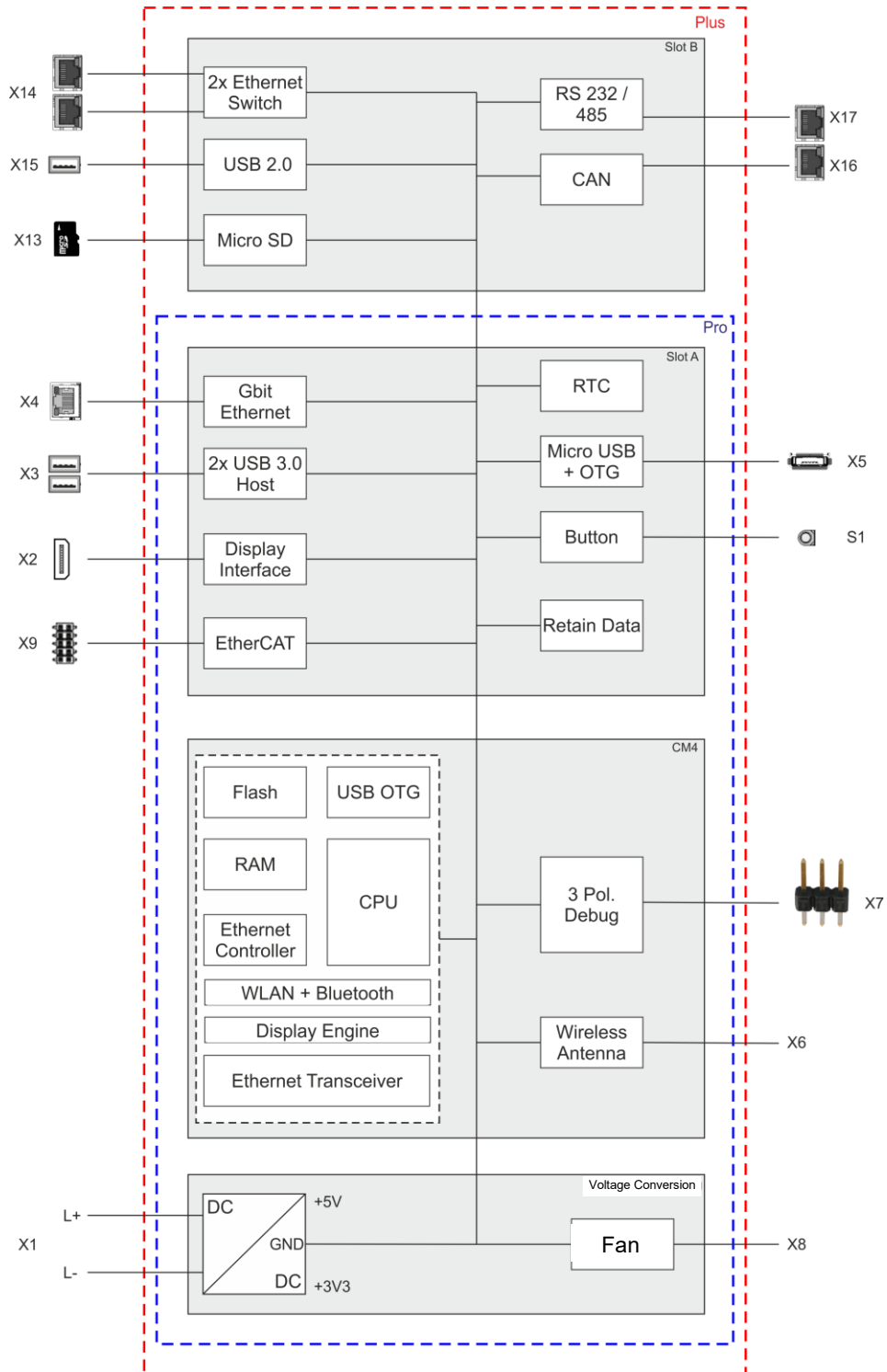



Fig.: 5 Block diagram of B-Nimis MC-Pi & BC-Pi

6.3.2. Network connection

The RJ-45 port X4 [ETH0] provides a Gigabit network connection (10/100/1000 Base-T). Furthermore, the MC/BC-Pi Plus has a second Ethernet interface with 10/100 Mbit/s. This is equipped with a 2-switch (2 ports X14 for the user and [ETH2] in the system). The status LEDs "SPEED" and "LNK/RCV" provide information about the network connection status according to IEEE 802.3 clause 40.

Pin assignment

LAN				
Stecker	Pin	Function	Pin	Function
 RJ45 X4	1	D1+	5	D3-
	2	D1-	6	D2-
	3	D2+	7	D4+
	4	D3+	8	D4-
 RJ45 X14	1	TX+	5	NC
	2	TX-	6	RX-
	3	RX+	7	NC
	4	NC	8	NC

Status-LEDs

LEDs		
LED	Color	Meaning
LED "SPEED"	yellow	ON = 100 Mbit/s, 1000 Mbit/s Off = 10 Mbit/s
LED "LNK/RCV"	green	Link, Data Receive Blinking: connection is active, data transfer OFF: no connection

NOTICE

Damage to the controller due to outdoors running network cables!



Network cables running outside buildings can endanger the control system through additional transients.

- For such installation situations, an additional surge suppressor must be used, e.g. 929121 DPA M CLE RJ45B 48 from the company Dehn or other similar devices.

6.3.3. USB interface

Devices with a USB interface can be connected to the USB host ports. The MC/BC-Pi Plus has a total of three USB ports. These include two USB 3.2 Gen 1 (X3) and one USB 2.0 (X15) ports. The available USB device classes for CODESYS users are USB sticks, keyboards, mice or USB serial adapters. For the compatibility of additional device classes, please contact your support team.

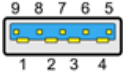
Pin assignment

USB-Connection				
Plug	Pin	Function	Pin	Function
  X3	4	VCC	9	SSRX-
	3	D-	8	SSRX+
	2	D+	6	SSTX-
	1,7	GND	5	SSTX+
 B1 ⋮ B4 X15	B1	GND		
	B2	D-		
	B3	D+		
	B4	VCC		

NOTICE

Damage to the USB drive and malfunctions due to data loss!

Removing a USB drive while it is still in use and data is being transferred can render the USB drive unusable. Open files which cannot be accessed due to removal of the USB thumb drive can block the device.

- ▶ Therefore, ensure that all data operations are complete before removing the USB drive.

NOTICE

Property damage and malfunctions due to data loss!

The USB interface is protected against overload (> 0.5 A). In the event of a short-circuit during operation, the controller can trigger a system reset.

This can result in considerable damage to property and damage to the USB device.

- ▶ Before using a USB device, check its power consumption.

NOTICE

Failures and malfunctions when connected directly to signal ground!

- ▶ Only use USB devices that do not have a direct connection between the signal ground and the housing.

USB drives can be inserted and removed during operation. The inserted USB drive is detected automatically and appears in the Linux directory/media/usbX. When the USB drive is removed, the directory /media/usbX is again removed from the directory structure.

Either the first partition on the USB drive, or, if the memory is not partitioned, the entire memory will be connected, i.e., the respective directory appears automatically.

The X represents a number from 1 (first USB device) to 8 (last/max. USB device).



The mechanical construction of the USB interface is designed for up to 1000 plugging cycles.

6.3.4. EtherCAT

The B-Nimis MC-Pi & BC-Pi PLC can be extended with a system of EtherCAT I/O modules (MC series or E-I/O) over the port X9 [ETH1]. The MC-I/O modules, which are lined up laterally to the right, are designed for the connection of a wide range of process signals (see Ether-CAT I/O manual).

The MC-Pi & BC-Pi simultaneously assume the function of the PLC and that of an EtherCAT bus coupler. Therefore, the EtherCAT communication signals are already converted internally to the LVDS (E-bus) transmission physics. As EtherCAT master, the MC-Pi & BC-Pi send EtherCAT telegrams for writing the output data and for reading the input data. The Ethernet EtherCAT protocol is maintained right down to the last individual I/O module. At the end of the modular device, the connection of the outward and return lines is closed automatically.

Furthermore, the system voltage of the connected I/O modules is generated in the MC-Pi & BC-Pi. Although this simplifies the connection of the I/O modules, the maximum number of connectable I/O modules must be taken into account.

Additional EtherCAT slaves can be connected to the MC-Pi & BC-Pi with an extender module.

NOTICE

The number of connectable EtherCAT I/O modules is limited!

Each EtherCAT I/O module generates an "E-bus load". This refers to the current load required to supply the internal device electronics. The MC-Pi & BC-Pi provides a current of up to 2 A for this purpose. This means that one MC-Pi & BC-Pi can supply up to a maximum of 10 I/O modules.

LED status indicators

The EtherCAT LEDs indicates the status of the EtherCAT ASICs.

EtherCAT		
State	LED, flash code	Meaning
Init	-	Initialisation, no data exchange
Pre-Op	Green, 1:1	Pre-operational status, no data exchange
Safe-Op	Green, 3:1	Safe operational status, inputs can be read
Op	Green, continuous light	Operational status, full data exchange

6.3.5. RS 485 / RS 232 interface

The device has a galvanically isolated serial communication interface (1x RS-232 or 1x RS-485), which is connected via the common RJ45 connector X17 [COM1].

- Maximum baud rate of both interfaces: 115 kBd
- Isolation voltage: 1000 VDC



Fig.: 6 RS 485 / RS 232 interface X17

Assignment RS 485 / RS 232 interface plug X17			
Pin	Assignment	Pin	Assignment
1	RS-232 RX / [COM1]	5	RS-485 Tx/Rx- / [COM1]
2	RS-232 TX / [COM1]	6	NC
3	NC	7	(reserved)
4	RS-485 Tx/Rx+ / [COM1]	8	ISO GND

The RS-485 interface is "soft" terminated in the Pi controller with 680 Ω

If the RS-485 interface is located at the start or end of the bus topology:

- ▶ set switch S3 to ON to connect the 120 Ω terminating resistor between Tx/Rx+ and Tx/Rx-.

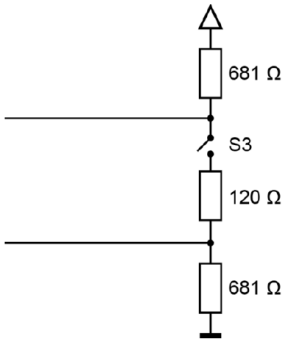

Fig.: 7 RS-485 switchable terminating resistor



The assignment of the interface should be carried out in accordance with the specifications given in “MODBUS over Serial Line; Specification and Implementation Guide V1.02”.

Signal interference and termination

To minimize interference, the following guidelines must be considered.

Driven bus

- A suitable protocol must ensure that at any time one of the bus nodes is actively driving the bus.
- For a high symmetrical signal-to-noise ratio, the bus must have defined states for logical "1" ($A-B < -0.2\text{ V}$) and for logical "0" ($A-B > +0.2\text{ V}$).

Floating bus

- An unbalanced bus termination must possibly provide for a sufficiently large signal-to-noise ratio (reduce the balanced signal-to-noise ratio).
- To achieve the necessary voltage difference between the signals, a suitable resistor network must be used as line termination.
- The necessary sizes of the resistors depend on the length of the bus and the data transfer rate (similar to the line termination for Profibus, see DIN EN 61158-2).

GND connections

To minimize common mode interference or malfunctions due to potential differences:

- ▶ Check the topology and cable lengths to determine whether additional connections to GND are necessary.
- ▶ For isolated interfaces with connection to the reference ground at one point: Also carry GND along.
- ▶ If necessary, provide for a damped connection of GND at several points on the bus (e.g. over $200\ \Omega$).

6.3.6. CAN interface

Properties of the CAN interface [CAN0]	
Standard	ISO 11898
Maximum baud rate	1 MBit/s
Lowest adjustable baud rate	50 kBit/s
Contacts	Electrically isolated
Insulation voltage	1000 VDC
Assignment	acc. to CiA303



Fig.: 8 CAN interface on X16

Assignment CAN interface plug X16			
Pin	Assignment	Pin	Assignment
1	CAN_H [CAN0]	5	NC
2	CAN_L [CAN0]	6	NC
3	ISO GND	7	ISO GND
4	NC	8	NC

If the CAN interface is located at the start or end of the CAN bus topology:

- ▶ set switch S2 to ON in order to switch on the 120 Ω terminal resistance between CAN_L and CAN_H.



▶ For baud rates, settings and cable length observe the recommendations of the CiA-303-1.
Example: at 1 Mbit max. 25 m

7. Operation

7.1. Switching on and off

NOTICE

Damage or malfunction!

- ▶ Do not insert, connect, disconnect, or touch any connections while the device is in operation.
 - ▶ Before starting any work on the device, switch off all power supplies, including those to any connected peripherals (externally powered encoders, programming devices etc.).
-

NOTICE

Damage to property!

- ▶ Before connecting the power supply, ensure that all cabling and the polarity of all the connections are correct.
-

Switching on

The device does not have an on/off switch. The device starts automatically when the system is switched on or the power is connected.

Switching off

The device is switched off when the system is switched off or the power supply is disconnected.

7.2. Initial start-up of the network

7.2.1. MC-Pi

Starting-up via the web interface

The device must be connected to the network with the correct settings before it can be used.

NOTICE

Damage to property!

- ▶ Before connecting the power supply, ensure that all cabling and the polarity of all the connections are correct.

1. Supply power to the device (24 V).
2. Connect the device to a programming computer using a network cable (X4) and network switch.
3. Open a web browser on the programming computer.
4. Enter `https://IP address of the device` into the web browser

The login window is displayed.



User Login:

Name:

Password:

Fig.: 9 Login window

5. Name: admin
The default password, which is printed on the device label, serves as the password.

NOTICE

Devices without a password on the device label

If your device does not have a password printed on the device label, the username and password are the same.

e.g. User: admin / Password: admin.

The web configuration page will be displayed.

Configuration

- [Network](#)
- [Time and Date](#)
- [FTP-Server](#)
- [SSH-Server](#)
- ▶ [WEB-Server](#)
- [VPN](#)
- [IXON](#)
- [Users](#)
- ▶ [WEB-Browser](#)
- [Reset Config](#)

System

- [Info](#)
- [Licenseinfo](#)
- [Update](#)
- [Reboot](#)

PLC-Manager

- [Control](#)
- [Config](#)
- [Application Info](#)
- [Application Files](#)

Fig.: 10 List of web interface settings

6. Click on the “Network” link.

The “Network Configuration” page will be displayed.

Network Configuration

COMMON

Hostname

Default Gateway

DNS Server 1

DNS Server 2

ETH0

Mode:

IPAdress

NetMask

ETH1

Mode:

Fig.: 11 Network Configuration page

7. Check the network settings and make any changes in the text boxes, if required.
8. Save the settings by clicking on “Save”.
9. Additional settings can also be viewed and/or modified on the web configuration page (e.g. “System time”, display resolution, TargetVisu).

10. In order to accept all of the modified settings, reboot the device:
By briefly disconnecting the device from the power supply.
– or –
Click on “Reboot” in the web interface and then confirm on the next page by clicking on “Reboot Module”.

The device is configured and ready for use.

7.2.2. BC-Pi

Standard start-up

The BC-Pi devices come with a pre-installed Raspberry Pi OS and are configured similarly to any other Raspberry Pi.

A detailed overview of the initial configuration in the Raspberry Pi OS can be found here:

<https://www.raspberrypi.com/documentation/computers/>

For easy setup it is recommended to use BC-Pi devices with connected monitor, keyboard and mouse and use the desktop interface of Raspberry Pi OS, alternatively just start the Linux terminal.

The network interfaces on the BC-Pi devices are configured as DHCP client by default and get an IP address automatically if they are connected to a network with DHCP server (e.g., a router).

The assigned IP is then listed in the client overview of the DHCP server or can be looked up in the Raspberry Pi OS and given a static IP if necessary

Start-up via SSH terminal

In case there are no peripherals available for setting up a BC-Pi device, it is possible to activate the SSH server in the BC-Pi with the help of a Windows PC in order to access the Linux terminal of the Raspberry Pi OS via the network.

1. Download the “rpiboot” tool found on: <https://www.raspberrypi.com/documentation/computers/compute-module.html#compute-module-4>
2. Install the tool and the drivers on your computer
3. Use a standard Micro-USB cable to connect the BC-Pi to your computer via X5 USB2.0/Boot.
4. Supply the BC-Pi with 24V DC voltage, Windows should now detect a new hardware and install the driver.
5. Run the installed “RPiBoot.exe” tool when driver installation is complete.
6. After a few seconds, the BC-Pi shows up as a mass storage device under Windows.
7. Open the mass storage drive with Windows Explorer and create an empty file with the name “ssh” (without file format extension)
8. Optional: If no DHCP server is available you can give the BC-Pi a static IP address with an entry in the “cmdline.txt”.
9. Optional: Open the “cmdline.txt” and add the following line of code (only one space, without line break):
ip=<client-ip>:<server-ip>:<gw-ip>:<netmask>:<hostname>:<interface>:<autoconf>
Here is an example of a simple IP-configuration:

```
ip=192.168.1.100:::255.255.255.0:bc-pi:eth0:off
```

10. Turn off the BC-Pi and disconnect the Micro-USB cable.
11. After a reboot the SSH server is activated and you can access the Linux terminal of the Raspberry Pi OS via the IP address set in the BC-Pi.

7.3. Operation

7.3.1. Status indicators

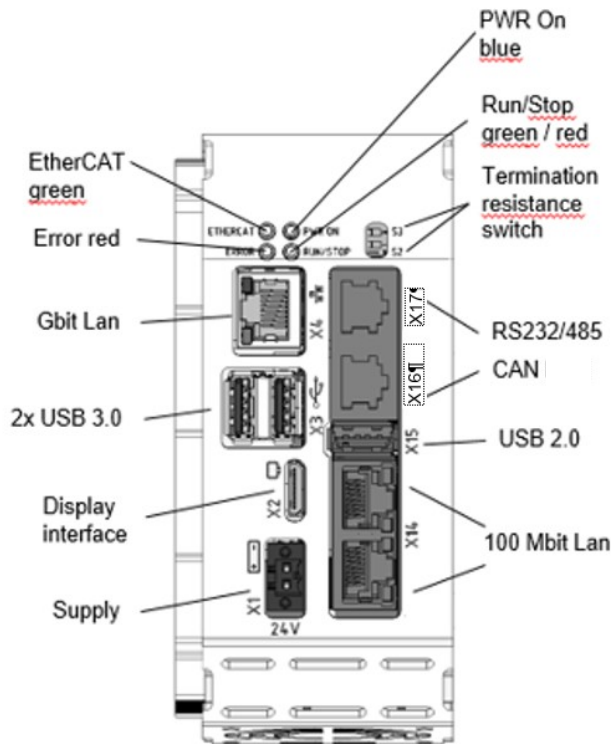

Fig.: 12 B-Nimis MC-Pi & BC-Pi status indicators

Power LED

4 operating status LEDs show the status of the power supply, the module mode and any error messages.

LED	Logical status
1 PWR (green)	ON = power supply to the module electronics is correct.

RUN/STOP button

Action	Command	
Boot phase	Change to maintenance mode	
CODESYS SPS	Short press	Change between RUN and STOP mode of the PLC
	Long press	Stop the PLC with RESET of variables (cold reset)

LEDs: RUN/STOP ERROR - LED indication

This chapter applies only for the MC-Pi series!

2 LEDs are available to indicate the system status (RUN/STOP in two colours: red/green/(yellow); ERROR in red only). The LEDs indicate the following system statuses:

System status	LED RUN/STOP	LED ERROR
PPP configuration mode active	Yellow	Off
USB package update active	Flashing yellow	Off
System error	Off	Red
PLC status		
RUN	Green	Off
STOP	Red	Off
Error stop	Red	Red
Reset detected	Flashing red	Off
Applicative states		
Identification of ProfiNET device	Flashing yellow	Flashing

Basic procedure for error stop:

- Determine the cause of the fault (by reading the web browser)
- Correct the cause of the fault
- Carry out a reset on the device, alternatively: Mode-selection switch / CODESYS/ web browser
- Put the controller back into operation

Ethernet status LED

See section: 10/100 Base-T network connection (Ethernet).

7.3.2. Real-time clock with battery back-up

The MC-Pi and BC-Pi are equipped with a real-time clock. The buffer time is 30 days.

Setting the date and time

The time can be set either via the web configuration page or via the CODESYS V3 library.

7.3.3. SD card

WARNING

Serious injury as a result of uncontrolled and unpredictable operational behaviour!

Inserting or removing the SD card can result in the device malfunctioning. The failure of electronic control systems may result in uncontrolled and unpredictable operational behaviour.

- ▶ Insert or remove an SD card only when the device is switched off.

Inserting an SD card

1. Switch the device off.
2. Insert the SD card into the SD card slot.
3. Switch the device on again.

The SD card is now ready for data transfer (read, write and copy).

Path: /media/sd



Max. possible storage capacity of an SD card: 2 TB.

The operating life of the gold-plated contacts is up to 10,000 plugging and unplugging cycles.

The SD card drive has a push-in/push-out insertion and ejection mechanism.

To avoid malfunction, the SD card may not be removed by pulling.

7.3.4. Start/Stop reset button

This chapter applies only to the MC-Pi series!

The Reset/Stop button is located on the front of the device below the status LEDs.

To prevent unintentional operation, the Stop/Reset button can only be operated with a thin pointed object (pen, screwdriver).

The function depends on the controller's current operating status

CODESYS Stop – Start – Reset

A running CODESYS application is stopped by briefly pressing the button. The Run / Stop LED changes from green to red. A second short press will start the CODESYS application. The Run / Stop LED changes from red to green. If the button is pressed and held for more than 5 seconds, a "Warm reset" is triggered. After the time has elapsed, the Run/Stop LED flashes quickly and the button can be released. The controller is now in the reset state.

Service mode

The controller must be switched off to enter service mode. The button is then held down and the controller is switched on again. The button must be kept pressed until the Run/Stop LED flashes yellow every two seconds.

7.4. Troubleshooting

7.4.1. No network connection

- ▶ Check the wiring/switch.
- ▶ Check whether an IP address has been assigned twice.
- ▶ Check the network settings on the PC: The subnet and subnet mask must match the settings in the controller.
- ▶ Check firewall/anti-virus programs on the PC.
- ▶ Check the Lifeguard setting.
- ▶ Check for an unknown IP address (see 7.4.3).

7.4.2. In error stop mode

- ▶ Log into device on web browser
- ▶ Establish cause of fault (Diagnostics > PLC Log/System Log).
- ▶ Correct the cause of the fault.
- ▶ Restart the device (press "Reset" on the device, also see 6.3.4).

Device is ready for use.

7.4.3. Unknown IP address

If the IP address of the device is unknown, a USB update can be carried out to reconfigure it.

1. Reboot the device while pressing and holding S1 until the Run/Stop LED flashes every 2 seconds.
The device is now in maintenance mode and can be reached via the default IP address.
2. Connect to the device using the default IP address:
IP address: 169.254.255.XX
Net mask: 255.255.255.0
XX corresponds to the last 2 digits of the device serial number. Exception: 00 becomes 100.
3. Correct the network settings and make a note of them.
4. Restart the device.
Maintenance mode is turned off automatically.
The device is configured and ready for use.

8. Servicing / Maintenance

Repairs and corrective maintenance may only be carried out by the manufacturer or its authorised customer service centres.

WARNING

Uncontrolled and unpredictable operational behaviour!

Failures or malfunctions may result in uncontrolled and unpredictable operational behaviour.

- ▶ Do not insert, connect, undo or touch any connections while the device is in operation.
- ▶ Before starting any work on the device, switch off all power supplies, including those to any connected peripherals (externally powered encoders, programming devices etc.).

If the device is used correctly, it should not require maintenance.

- ▶ Make sure all the ventilation openings are kept free of obstructions
- ▶ Do not open the device. If it is necessary to work in the device, contact the Service department.

9. Disassembly

1. Disconnect the device and associated peripherals from the power supply. Unplug all plugs and cables.

NOTICE

Damage to the device!

If disassembly is performed carelessly the device can fall down from the top-hat rail or get damaged.

- ▶ Do not tilt the device.
- ▶ Secure the device to prevent it from falling, particularly when removing it from the control cabinet.

Push the module up and against the metal spring on the lower end of the rail guide. Press the module at the top against the mounting wall until it snaps into place. Turn the module forwards away from the mounting rail as shown in the illustration. Pull the module down off the mounting rail.

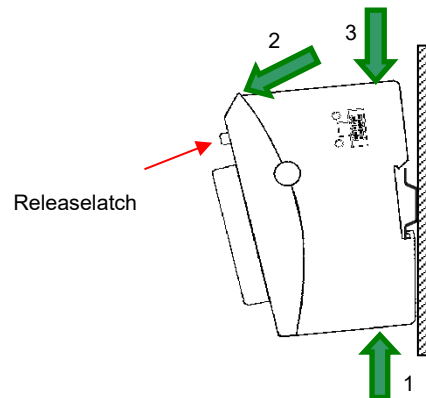

Fig.: 13 Disassembling the B-Nimis MC-Pi & BC-Pi

10. Disposal

The device contains the following components which need to be disposed of separately:

- Metals
- Electronic components

The respective national regulations for the disposal of electrical appliances in B2B business apply.

The following options are available for disposal of the device:

Disposal by the manufacturer

Unless otherwise agreed, devices can be returned for disposal.

Disposal in accordance with regional regulations

- ▶ Dismantle the device and disassemble it completely into its component parts.
- ▶ Send the metal parts for metal recycling.
- ▶ Sort the electronic parts (circuit boards, drives, etc.).
- ▶ Dispose of electronic scrap in accordance with the national laws and regulations.

11. Information and options

11.1. Type plate

Fig.: 14 Type plate

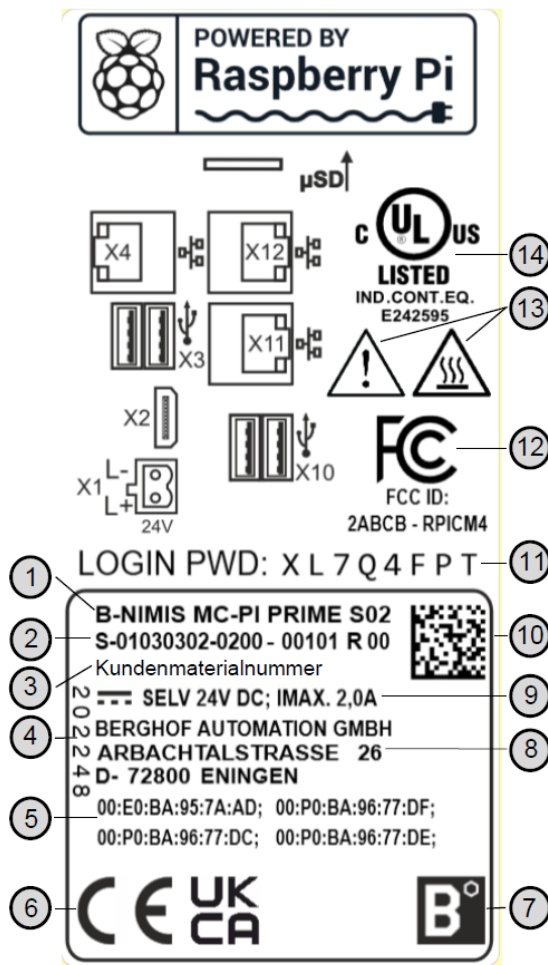

Pos.	Description
1	Product description
2	Order number / serial number / version identification
3	Customer material number
4	Production date (year/week)
5	MAC addresses of the unit
6	Conformity marking
7	Logo of the manufacturer
8	Manufacturer (manufacturer's address)
9	Supply voltage and maximum current
10	QR code (identification no.)
11	Default password
12	FCC marking
13	Hazard label
14	UL marking

11.2. Device variants and Memory configuration levels

Description	Order Number	Characteristics
B-Nimis MC-Pi-Plus S01	S-01030303-0100	1 GB RAM / 8 GB eMMC
B-Nimis MC-Pi-Plus S02	S-01030303-0200	2 GB RAM / 8 GB eMMC
B-Nimis BC-Pi Plus S01	S-01080103-0100	1 GB RAM / 8 GB eMMC
B-Nimis BC-Pi Plus S02	S-01080103-0200	2 GB RAM / 8 GB eMMC
B-Nimis BC-Pi Plus S03	S-01080103-0300	4 GB RAM / 32 GB eMMC
B-Nimis BC-Pi Plus S04	S-01080103-0400	8 GB RAM / 32 GB eMMC

11.3. Options and extensions

Options are ordered via the combination
"Order number option1 option 2..."

e.g.: **S-01030102-0100 S001 S002 H001**

In addition to the order number, additional extensions in the form of hardware, software and customised options are indicated as follows:

Option code	Option type
S000-S999	Software options e.g. field buses
H000-H999	Hardware options e.g. plug kit, certifications
C000-C999	Customised options e.g. customised firmware, customised front membrane display

For more information about the options available for this device, please refer to our product catalogue or website.

The additional features included or installed in each device are listed on the options label. This label can be found on the device and/or on the packaging.

12. Standards and certificates

12.1. Standards

Applicable directives

- EMV-directive 2014/30/EU
- RoHS-directive 2011/65/EU
- RED-directive 2014/53/EU

Applicable standards

- Standard
EN 63000:2019-05
- PLC standard
EN 61131-2:2008-4
- Emission standard
EN 61000-6-3:2012-11
- Safety provisions
DIN EN 61010-2-201

12.2. Declaration of Conformity/Technical data

The declarations of conformity, technical data and further information can be found on our website at:

<https://www.berghof-automation.com/>

Select the corresponding field (Automation technology) and complete the form. Information on data protection can also be found on the page.

Technical data for MC-Pi Plus and BC-Pi Plus can be found in the modular controllers category.

If a document is missing, it can be requested via our contact form at

<https://www.berghof-automation.com/en/contact>

13. Customer services / addresses

Repairs and corrective maintenance may only be carried out by the manufacturer or its authorised customer service centres.

13.1. Customer services

Berghof Automation GmbH
Arbachtalstrasse 26
72800 Eningen
Germany
T +49.7121.894-183
F +49.7121.894-100
email: support-controls@berghof.com
<https://www.berghof-automation.com>

13.2. Repair service

Please send the goods to the Berghof repair service for repairs, stating the RMA number and a detailed description of the fault..

Berghof Automation GmbH
BU Automatisierungstechnik
Reparaturservice
Arbachtalstrasse 26
72800 Eningen

You can request the RMA number at:
www.berghof-reparaturservice.com

13.3. Addresses

CAN in Automation; international manufacturer and user organisation for CAN users in automation:

CAN in Automation e.V. (CiA)
Am Weichselgarten 26
91058 Erlangen, Germany
headquarters@can-cia.de
www.can-cia.de

EtherCAT Technology Group
ETG Headquarters
Ostendstrasse 196
90482 Nürnberg, Germany
info@ethercat.org
www.ethercat.org

Beuth Verlag GmbH, 10772 Berlin, Germany
or
VDE-Verlag GmbH, 10625 Berlin, Germany
or
Internet research: www.iec.ch

14. Appendix

14.1. Notes on copyright and the software licence

The firmware of the device contains software components that are licensed by the copyright holders as free software.

These parts are available under the following and other OpenSource licenses:

- GPL (GNU General Public License), Version 1/Version 2/Version 3
- GNU Lesser General Public License (LGPL), Version 2.1/Version 3
- Mozilla Public License (MPL)
- FreeType License (FTL)

You can view and download the valid license conditions for the software components contained in the device in our download area <https://www.berghof-automation.com/en/downloads> under the category “Modular Controllers” → „B-Nimis MC-Pi Plus“
or
under the category „Industry PC“ → „B-Nimis BC-Pi Plus“

This software is distributed in the hope that it will be useful, but WITHOUT ANY WARRANTY; without even the implied warranty of MERCHANTABILITY or FITNESS FOR A PARTICULAR PURPOSE. See the GNU General Public License for more details.

Anyone can obtain the source code for these software components from us on a data carrier (CD-ROM, DVD or USB memory stick). This offer is valid within three years after the most recent distribution of the object code by us.

Please send your request to the following email address:

support-controls@berghof.com

or via regular mail to the following address:

Berghof Automation GmbH
Technical Support - Controls
Arbachtalstrasse 26
72800 Eningen
Deutschland

Please specify the address to which you wish us to send the source code. Additional product information (e.g. explicit product name, serial number etc.) will help us to identify the corresponding source code for you. The source code will be sent to the given address after reimbursement of the expenses actually incurred for providing the data carrier and shipping.

14.2. List of figures

Fig.: 1 Overview of B-Nimis MC-Pi Prime and BC-Pi Prime	15
Fig.: 2 Installing the B-Nimis MC-Pi & BC-Pi	21
Fig.: 3 Disconnecting the B-Nimis MC-Pi & BC-Pi	22
Fig.: 4 Earthing	25
Fig.: 5 Block diagram of B-Nimis MC-Pi & BC-Pi	26
Fig.: 6 RS 485 / RS 232 interface	30
Fig.: 7 RS-485 switchable terminating resistor	31
Fig.: 8 CAN interface on X16	32
Fig.: 9 Login window	34
Fig.: 10 List of web interface settings	35
Fig.: 11 Network Configuration page	35
Fig.: 12 B-Nimis MC-Pi & BC-Pi status indicators	38
Fig.: 13 Disassembling the B-Nimis MC-Pi & BC-Pi	44
Fig.: 14 Type plate	46
Fig.: 15 Label for Options	48