

B-PRIMIS DC-Pi PRIME series

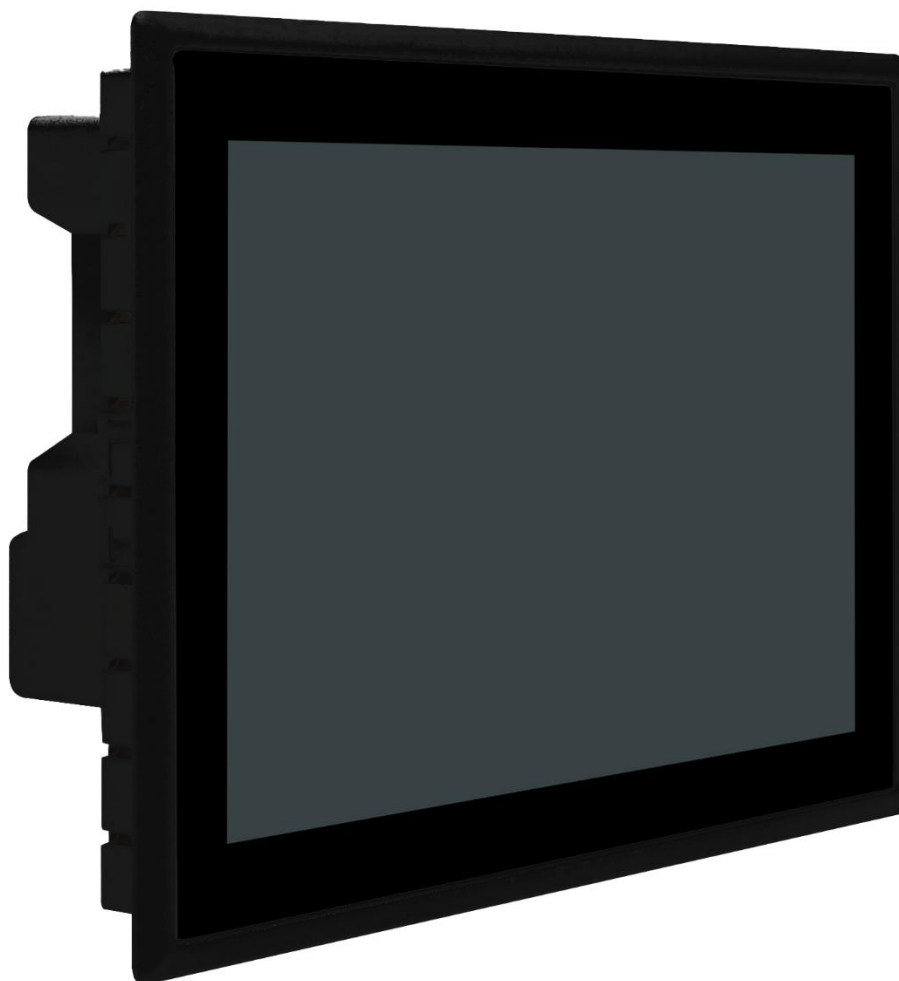

Copyright © Berghof Automation GmbH

This document may not be passed on or reproduced, and its contents may not be utilised or communicated without our express consent. All rights reserved.
Infringements will result in compensation for damages.

Disclaimer

The content of this publication has been checked for conformity with the hardware and software described. However, deviations cannot be ruled out, so we cannot guarantee complete conformity. The information in this publication is checked regularly, and any necessary corrections are included in subsequent editions. Suggestions for improvement are always welcome. We reserve the right to make technical changes.

Trademark

- EtherCAT® is a registered trademark and a patented technology, licensed by Beckhoff Automation GmbH, Germany.
- CiA® and CANopen® are registered community trademarks of CAN in Automation e. V.
- ARM® and Cortex® are registered trademarks of ARM Limited.
- PROFINET® is a registered trademark of the PROFIBUS User Organization e. V.
- Modbus® is a registered trademark of the Modbus-IDA organisation.
- Raspberry Pi is a registered trademark of the Raspberry Pi Foundation.
- KNX is a registered trademark of the KNX Association.
- BACnet is a protocol the rights are owned by the organization BACnet International.
- Ethernet/IP is a registered trademark of the Open DeviceNet Vendors Association.
- CODESYS is a registered trademark of the CODESYS GmbH.

The rights to all companies and company names as well as goods and product names mentioned here are held by the respective companies.

Notes on this manual

This manual:

- This manual contains the product-specific information valid at the time of publication.
- should be read carefully before commissioning the appliance in order to avoid errors during operation and to familiarize yourself with the appliance.
- It is only complete together with the product-related hardware and software user manuals required for the respective application.
- does not include repair instructions. If repairs are required, please contact your supplier or Berghof Automation GmbH directly

You can reach us at
Berghof Automation GmbH
Arbachtalstrasse 26
72800 Eningen
Germany
T +49.7121.894-0
E-mail: controls@berghof.com
www.berghof-automation.com

Berghof Automation GmbH is certified according to DIN EN ISO 9001.

Change log

Version	Date	Description
1.0	30.04.2025	Draft version
1.1	19.05.2025	Formal corrections
1.2	29.07.2025	Correction of the dimensions at DC-Pi Prime 15 mounting cut-out
1.3	20.02.2026	Description of device variants S01, S02, S04 Revision of sections on real-time clock Extension of sections microSD card (SDHC and SDXC) EMC IP protection category Formal correction of Ethernet assignments Addition of MicroSD card for device variants Overview: Device specifications S01 NEW
1.4	23.03.2026	Formal corrections Correction of the number of securing clips with 15” Revision “Trademark” Adjustment Certification DIN EN ISO 9001 Information regarding UL certification added
1.5	12.06.2026	Correction Power consumption DC-Pi Prime 15 Information regarding UL certification and Protection category added

Table of contents

1.	GENERAL INFORMATION	7
1.1.	Notes on the manual	7
1.2.	Symbols and visual depictions	8
1.3.	Hazard categories and signal terms	8
1.4.	Qualified personnel	9
1.5.	Duty of care	9
1.5.1.	General	9
1.6.	Intended use	10
1.7.	Transport and storage	11
	Transport and storage	11
	Operation	11
1.8.	Unpacking	11
2.	SECURITY	12
2.1.	Safety related systems	12
2.2.	Safety instructions	12
	Working on the device	13
2.3.	Cyber Security	13
3.	PRODUCT DESCRIPTION	14
3.1.	Overview	15
3.2.	Scope of delivery and accessories	16
	Scope of delivery	16
	Accessories	16
3.3.	Product features	17
	Performance features at a glance	17
	Installation	17
	Processor	17
	Ethernet	17
	EtherCAT	17
	USB	17
	CAN interface	17
	Serial interface	17
	Optional extension: Digital and analogue inputs/outputs	18
	Real-time clock	18
	µSD card	18
4.	INSTALLATION	19
4.1.	Preparation for front installation DC-Pi Prime 7	19
4.2.	Preparation for front installation DC-Pi Prime 10	21
4.3.	Preparation for front installation DC-Pi Prime 15	23
4.4.	Installation	25

5.	CONNECTION	28
5.1.	Power supply	28
	Installation	28
5.1.1.	Connecting the power supply	29
5.2.	Data connections	30
5.2.1.	Block diagram.....	30
5.2.2.	Digital inputs and outputs	31
5.2.3.	DC Pi Prime connector overview from version S02	31
5.2.4.	Analog inputs and outputs	36
	Basics for connecting the analogue inputs	36
	Data of the analogue inputs (both resolutions)	38
	Operating modes of the analogue inputs with 12-bit resolution	39
	Data of the analogue outputs	44
5.2.5.	Connection examples	46
	Voltage output AO (U) on X11.....	46
	Voltage input AIN (U) on X11	47
	Temperature measurement AI (PT)	48
	2-wire measurement.....	48
	3-wire measurement.....	48
5.2.6.	Ethernet	49
5.2.7.	USB	50
5.2.8.	CAN bus	51
5.2.9.	Serial interfaces.....	52
	Signal interference and terminating resistor	53
	Connections with GND	53
6.	OPERATION	54
6.1.	Switching on and off	54
	Switch on	54
	Switch off	54
6.2.	Initial Setup of the device	55
6.2.1.	Web interface configuration.....	55
6.3.	Operation	58
6.3.1.	Status indicators	58
6.3.2.	Real-time clock with voltage buffer.....	59
	Set date/clock	59
6.3.3.	µSD- card	59
6.3.4.	Start/stop reset button S1.....	60
	CODESYS Stop - Start - Reset	61
	Service Mode.....	61
6.4.	Troubleshooting	62
6.4.1.	No network connection	62
6.4.2.	With error stop	62
6.4.3.	IP address unknown	62
6.5.	Berghof Control System Manual	63
7.	MAINTENANCE / SERVICING	64
7.1.	Maintenance	64

7.2. Cleaning	64
8. UNINSTALLATION	65
9. DISPOSAL	68
10. INFORMATION AND OPTIONS	69
10.1. Device variants DC-Pi Prime 7 / 10 / 15	73
10.2. Type plate	74
10.3. Device variants and identification	75
10.4. Options and extensions	76
11. STANDARDS AND CERTIFICATES	77
11.1. Standards	77
EU directives applied	77
EU standards applied	77
UKCA guidelines applied	77
UKCA standards applied	77
11.2. Declaration of conformity	78
12. CUSTOMER SERVICE / ADDRESSES	79
12.1. Customer service	79
12.2. Repair service	79
12.3. Addresses	80
13. APPENDIX	81
13.1. Notes on copyright and license of the software	81
13.2. List of illustrations	81

1. General information

Please read this user manual carefully before commissioning. Failure to do so may result in damage to the appliance and injury to operating personnel.

Safety-relevant instructions and their classifications are explained in the section Hazard categories and signalling terms (1.3). These instructions must always be observed!

1.1. Notes on the manual

This user manual is part of the product and applies to the following devices:

- B-Primis DC-Pi Prime 7 S01 ; S02 ; S04
- B-Primis DC-Pi Prime 10 S01 ; S02 ; S04
- B-Primis DC-Pi Prime 15 S01 ; S02 ; S04

1.2. Symbols and visual depictions

The following symbols and visual depictions are used in this user manual:

Symbol	Meaning
→ ...	List entry
▶ ...	Individual instructions or a list of instructions that can be carried out in any order.
1. ... 2. ...	List of instructions that must be carried out in the specified order.
	Additional product information

Design of warnings:

1.3. Hazard categories and signal terms

The signaling terms described below are used for warnings that you must observe for your personal safety and to prevent damage to property.

The signal terms have the following meaning:

DANGER

Serious injury or death

Non-compliance with the safety features will result in death or serious injury.

- ▶ Observe actions for prevention.

WARNING

Possible serious injury or death

Non-compliance with the safety features may result in death or serious injury.

- ▶ Observe actions for prevention.

CAUTION

Possible minor injuries

Non-compliance with the safety features may result in minor injuries.

- ▶ Observe actions for prevention.

NOTE

Possible material damage

Non-compliance with the safety features may result in damage to property.

- ▶ Observe actions for prevention

1.4. Qualified personnel

Installation, start-up and maintenance of the device requires qualified personnel.

Qualified personnel in the sense of this documentation and the safety instructions contained therein are trained specialists who are familiar with the safety concepts of automation technology and who are authorized to assemble, install, start-up, ground and label devices, systems and circuits in accordance with the standards of safety technology.

1.5. Duty of care

1.5.1. General

The operator or further processor (OEM) must ensure the following:

- The device is only used as intended.
- The appliance may only be operated if it is in perfect working order.
- The user manual is always available in legible condition and complete.
- Only suitably qualified and authorized specialists may assemble, install, commission and maintain the appliance.
- These specialists are regularly instructed in all applicable issues of occupational safety and environmental protection and are familiar with the contents of the user manual, particularly the safety instructions contained therein.
- The device markings and identifications as well as safety and warning notices attached to the device are not removed and are always kept in a legible condition.
- The national and international regulations for the control of machines and systems applicable at the respective place of use of the device are complied with.
- Users always have all the latest information on the device and its use and operation that is relevant to their needs.
- The user is responsible for coordinating the use of the safety-related control components with the responsible authorities and complies with their specifications.

1.6. Intended use

The device is part of a modular automation system for industrial control applications in the medium to upper performance range.

The automation system is designed for use within overvoltage category I (IEC 60364-4-44) for the control and regulation of machines and industrial processes in low-voltage systems with the following general conditions:

- Maximum rated supply voltage, 1000 V AC voltage (50/60 Hz) or 1500 V DC voltage
- Environment with maximum pollution degree 2 (EN 61010-1)
- Altitude up to 2000 m N. N.
- Only indoors without direct UV radiation
- Max. Ambient temperature according to the technical specifications see "technical data", p. 68

The faultless and safe operation of the automation system requires qualified project planning, proper transport, storage, installation and use as well as careful maintenance.

The automation system may only be used within the scope of the data and applications specified in this documentation and the associated user manuals.

The automation system must only be used:

- as intended
 - in a technically perfect condition
 - without any unauthorized modifications
 - by qualified users
-
- ▶ Observe the regulations of the trade associations, the Technical Inspection Association, the VDE regulations or corresponding national regulations.
 - ▶ The device is intended for installation in a suitable mounting cut-out on industrial machines and systems indoors.
 - ▶ When installing make sure that the existing sealing profiles are undamaged.
 - ▶ Observe the ambient conditions applicable to operation, see "technical data", p. 68



The device is optionally available with UL certification.

This complies with UL Enclosure Type 1. Suitable installation must be ensured.

1.7. Transport and storage

The device is sensitive to shocks, strong vibrations, moisture and extreme temperatures.

Transport and storage

- ▶ Protect the device from heavy mechanical stress during transport.
- ▶ Always transport the device in its original packaging.
- ▶ Observe the ambient conditions applicable for storage, see "technical data", p.68
- ▶ Ensure that the device is protected from exposure to moisture and humidity.

Operation

- ▶ Do not operate the device after storage or transport until it has reached the permissible operating conditions.
- ▶ Wait at least 12 hours after condensation before operating the device.

1.8. Unpacking

On receipt of the device, it must be ensured that the packaging is undamaged and complete.

- ▶ Check the packaging for external damage.
- ▶ In the event of serious damage to the packaging or if damage to the contents is recognizable: Do not open the packaging any further and inform the carrier and your supplier immediately.
- ▶ Remove the packaging and keep the packaging for re-transport.
- ▶ Check the contents for recognizable transport damage.
- ▶ Check the contents against the order for completeness and be sure to keep all documentation supplied. The documentation supplied contains important information about the device and is an integral part of the product.
- ▶ If you notice transport damage or discrepancies between the order and the delivered contents: Inform the supplier immediately.

2. Security

2.1. Safety related systems

The use of Ethernet Terminals in safety-related systems requires specific measures. Wherever a Ethernet Terminal is to be used in a safety-related system, the user must be given comprehensive advice by the manufacturer in addition to information on any available standards or regulations regarding safety installations.

- ▶ Before starting any work on devices, switch off all power feeds, including to peripherals.
- ▶ Keep all ventilation holes unobstructed.

Failure in certain components in an electronic control system may result in uncontrolled and/or unpredictable operational behavior.

- ▶ All types of failure must be considered at the system level and the associated preventative measures identified.
- ▶ If necessary, request information from your automation system provider.

2.2. Safety instructions

CAUTION

Possible minor injuries and burns to the skin surface.

Failure to observe the safety measures may result in minor injuries / burns to the skin surface!

The device may be operated only when it is in good working order. Exposed sharp edges pose an injury risk.

- ▶ If you discover damage to the front glass of the device, do not continue to operate the device. Immediately disconnect it from the power supply.

The housing of the device can heat up considerably, especially at elevated ambient temperatures, due to the passive cooling of the internal components. The surface temperature may exceed the burn threshold depending on the duration of contact.

- ▶ If possible, avoid touching the rear panel of the device during operation.
 - ▶ If you plan to perform any work on the device, such as installing or removing it in the control cabinet or connecting or disconnecting a cable, switch off the device and allow it to cool down for a while.
 - ▶ It is recommended to wear personal protective equipment such as gloves when handling the heated device.
-

Working on the device

Do not start work on the device until all necessary safety precautions have been taken. Take precautions to avoid unforeseeable functional events and movements of the system.

- ▶ Bring the system into a safe condition.
- ▶ Switch the system and the device off.
- ▶ Secure the system against being switched on again.
- ▶ Disconnect the device from the system.

The casing of the device must not be opened.

- ▶ If work on the internal parts of the device is necessary, contact the manufacturer (see "Addresses").

2.3. Cyber Security

- ▶ Never place the control unit on the Internet without additional protection mechanisms, this product is not designed for this purpose
- ▶ Change the default passwords specified on delivery
- ▶ Always use an upstream external firewall to prevent access from the outside to the inside.
- ▶ Use the security mechanisms of VPN server portals (e.g. IXON) to which the controller can actively connect via VPN or comparable mechanisms
- ▶ Always use https instead of http
- ▶ Deactivate unnecessary services such as (FTP/SSH/Webserver)

Contact person for cybersecurity of Berghof products:

Berghof Product Security Incident Response Team

psirt.automation@berghof.com

3. Product description

The B-Primis DC-Pi Prime series dialogue controller is a control module with a display. For the control and regulation of automatic and industrial processes in low-voltage systems with real-time characteristics.

The CODESYS (IEC 61131-3) development environment is used for programming.

The connection level of the devices for all external connections is located on the underside. These devices are intended for installation in a prepared mounting cut-out in a flat surface. All connections are pluggable.

3.1. Overview

Device specification S01

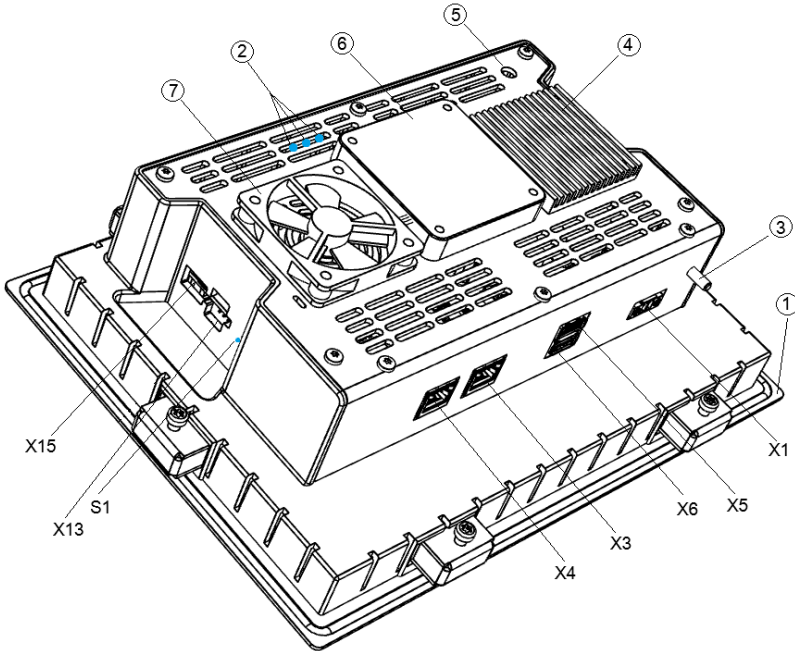

Fig. 1: Overview of B-Primis DC-Pi Prime 10 S01 (rear)

Device specification S02-S04

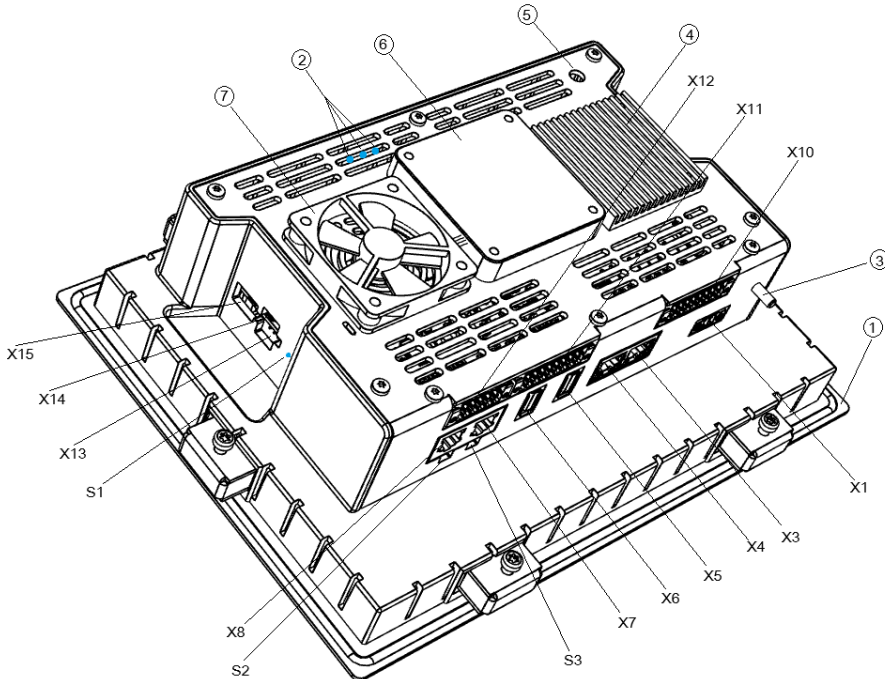

Fig. 2 : Overview of B-Primis DC-Pi Prime 10 S02-S04 (rear)

Pos.	Designation	Pos.	Designation
1	Display 10.1 inch		
2	LEDs: Power, Run/Stop, Error	X7	RS-232 [COM1] / RS-485 [COM2] combined
3	Earth connection	X8	CAN bus [CAN0]
4	Cooling (optional)	X10	Digital inputs / outputs (optional) with own supply connection
5	WLAN-Antenna slot (optional)	X11	Analogue inputs & outputs (optional)
6	Vesa mount (optional)	X12	High-precision analogue inputs (optional)
7	Fan (optional)	X13	Debug interface (do not use - only for Berghof service personnel)
X1	Power supply	X14	MicroSD cards slot (SDHC and SDXC) (S02 and higher)
X3	Ethernet [ETH0]	X15	USB device (do not use - only for Berghof service team)
X4	Ethernet [ETH1]	S1	Function button (reset and run/stop)
X5	USB host	S2	Terminating resistor CAN
X6	USB host	S3	Terminating resistor RS485

3.2. Scope of delivery and accessories

Scope of delivery

- B-Primis DC-Pi Prime
- 2-pin power supply plug
- I/O plug 12-pin from version S04
- I/O plug 18-pin from version S04
- Securing clips:
 - DC-Pi Prime 7"/10": 6 pieces
 - DC-Pi Prime 15: 10 pieces

Accessories

The following accessories can be ordered directly or via the options (see chapter 10.4):

- Securing clip, order no. S-02060201-0100
- DC-Pi Prime S04 plug set, order no. S-02020107-0100
- Power supply plug DC-Pi Prime, order no. S-02020203-100

3.3. Product features

Performance features at a glance

- Raspberry Pi CM4 (1.5 GHz Quad Core)
- Program and data memory (RAM): 1 GB to 8 GB RAM
- Program memory (Flash): 8 GB to 32 GB eMMC Flash
- Retain memory 100 kB
- 2 Ethernet 1000/100/10 Base-T interfaces
- 2 USB host interfaces
- 1 CAN interface
- 2 serial interfaces (1x RS-232; 1x RS-485)
- 1 μ SD card slot from S02 onwards (suitable for SDHC and SDXC)
- Optionally expandable: Digital & analogue I/O
- Real-time clock

Installation

The device is designed for installation in a front panel or in a control panel in a rough industrial environment.

Processor

The device has a Raspberry Pi Compute Module 4 in the basic configuration (1.5 GHz Broadcom BCM2711, Quad Core Cortex-A72 (ARM v8) 64-bit SoC) Depending on the selected variant with different storage expansion.

Ethernet

Two Ethernet interfaces with 10/100/1000 Mbit/s are available. The TCP/IP and UDP/IP protocols enable a very flexible connection to visualization software, to higher-level control units or to the IT infrastructure.

EtherCAT

Every Ethernet interface can also be used as an EtherCAT master interface.

Other available Ethernet interface protocols: PROFINET, Ethernet/IP, OPC UA, BACnet, KNX and Modbus TCP.

USB

The USB 3.2 Gen 1 (S02, S04)/ USB 2.0 (S01) host interface is a widely used peripheral interface. This enables simple data exchange or expansion with compatible USB devices.



USB sticks with FAT/FAT32/exFAT/ext3/ext4 formatting are supported.

For support of other USB devices, please contact our technical support.

Visualization

CODESYS web and target visualization is included in the scope of delivery of the DC-Pi device.

CAN interface

The device has a standard CAN interface that can be used up to 1 Mbit/s.

Serial interface

The device has 2 serial interfaces (1x RS-485; 1x RS-232), which are provided in combination on the same RJ45 socket.

Optional extension: Digital and analogue inputs/outputs

The device can optionally be ordered with digital inputs/outputs and analogue inputs/outputs with different resolutions and accuracies.

Real-time clock

A maintenance-free real-time clock buffered with a capacitor can be set to the current time via a software interface. The buffer time is 30 days.

µSD card

The DC-Pi-Prime has 1 x µSD card slot, e.g. for data dumps.

This slot is suitable for all SDHC and SDXC µSD cards and available from variant S02 onwards.

4. Installation

4.1. Preparation for front installation DC-Pi Prime 7

The device is intended for installation from the front into a rectangular cut-out on a panel. The support material must be rigid and be from 1 to 3 mm thick.

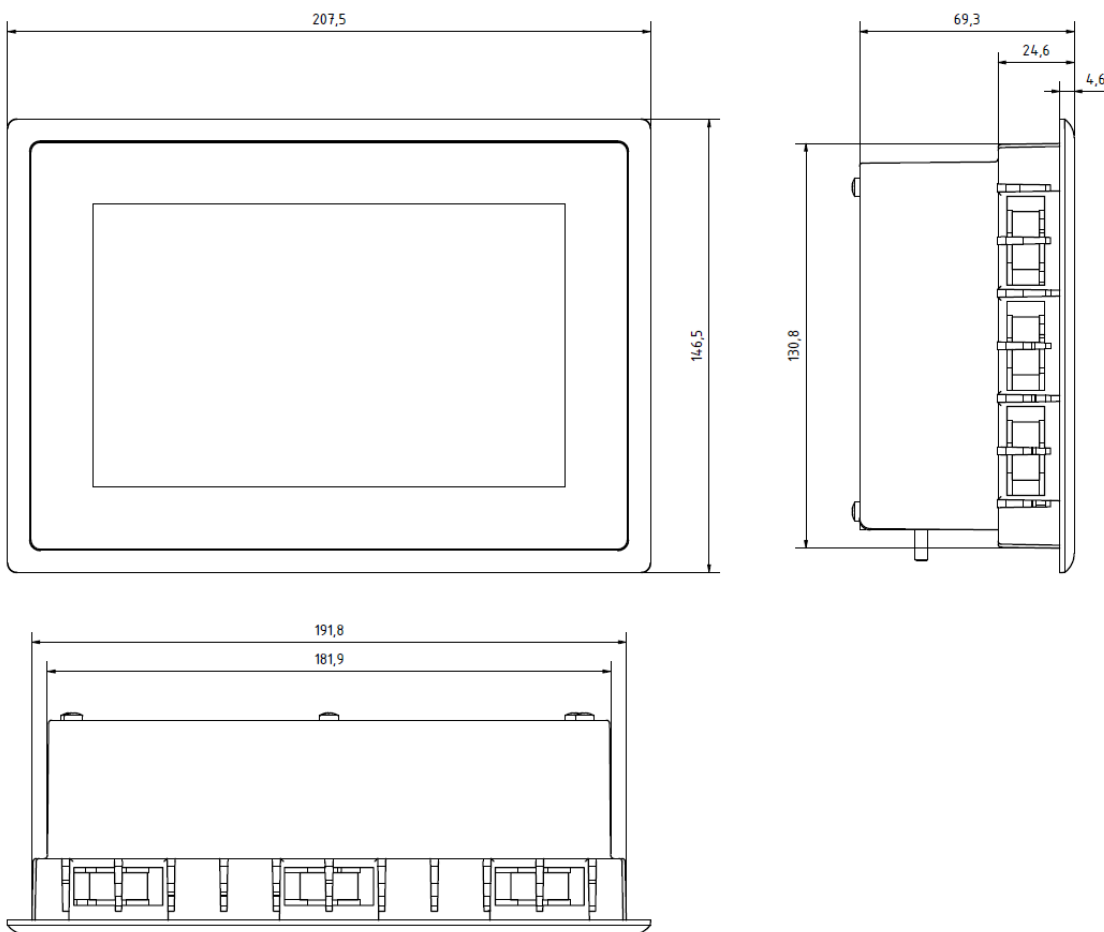

Fig. 3: Dimensions DC-Pi Prime 7

Requirements:

- To allow sufficient air circulation, it must be ensured that the device has a clear space of at least 20 mm all round at the rear.
- The carrier material for the mounting cut-out is sufficiently thick, flat and stable.

NOTE

Damage to the device!

Installation on uneven support material can lead to mechanical stresses and cracks in the front face or malfunctioning of the touch screen.

- ▶ Make sure that the mounting points of the device are all in a common plane, with no more than maximum ± 0.5 mm variation.

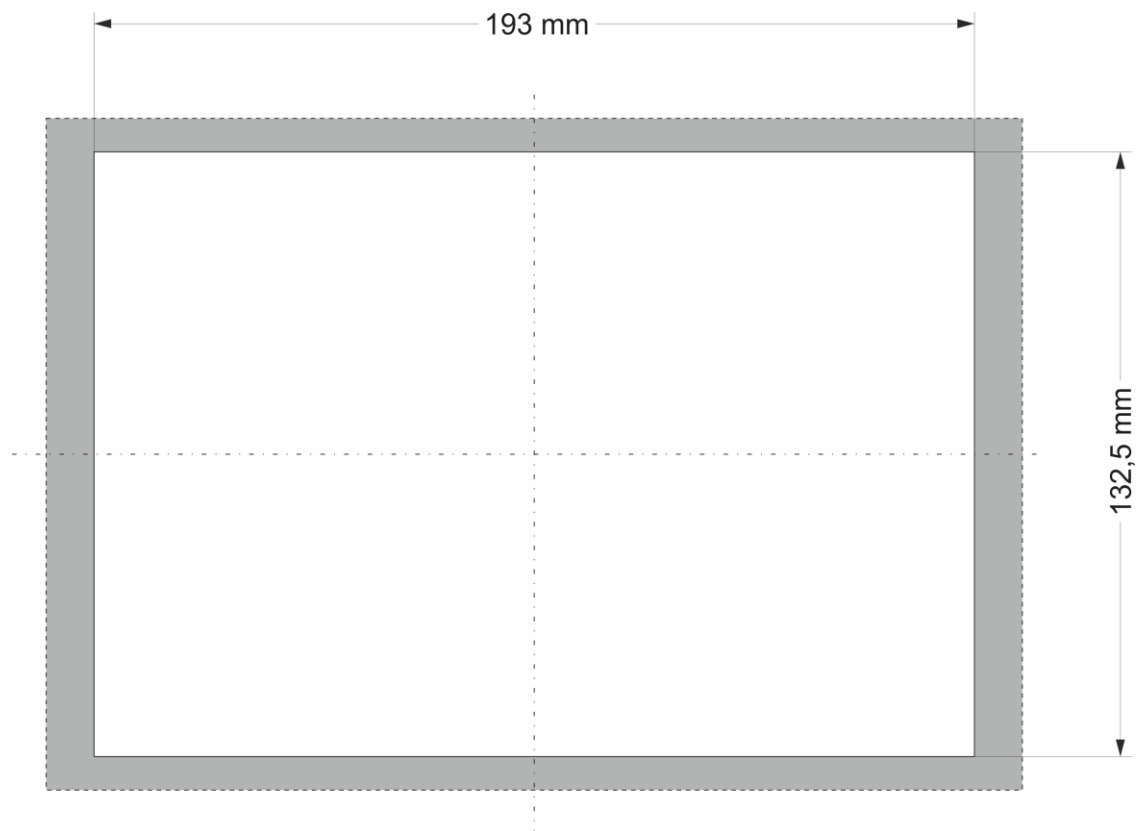

Fig. 4: DC-Pi Prime 7 mounting cut-out

- ▶ Cut a rectangular mounting cut-out from the backing material:
 Height: 132.5 mm
 Width: 193 mm
 Max. corner radius: 1.5 mm



Optimum thickness of the carrier material: 1.0 to 3.0 mm

4.2. Preparation for front installation DC-Pi Prime 10

The device is intended for installation from the front into a rectangular cut-out on a panel. The support material must be rigid and be from 1 to 3 mm thick.

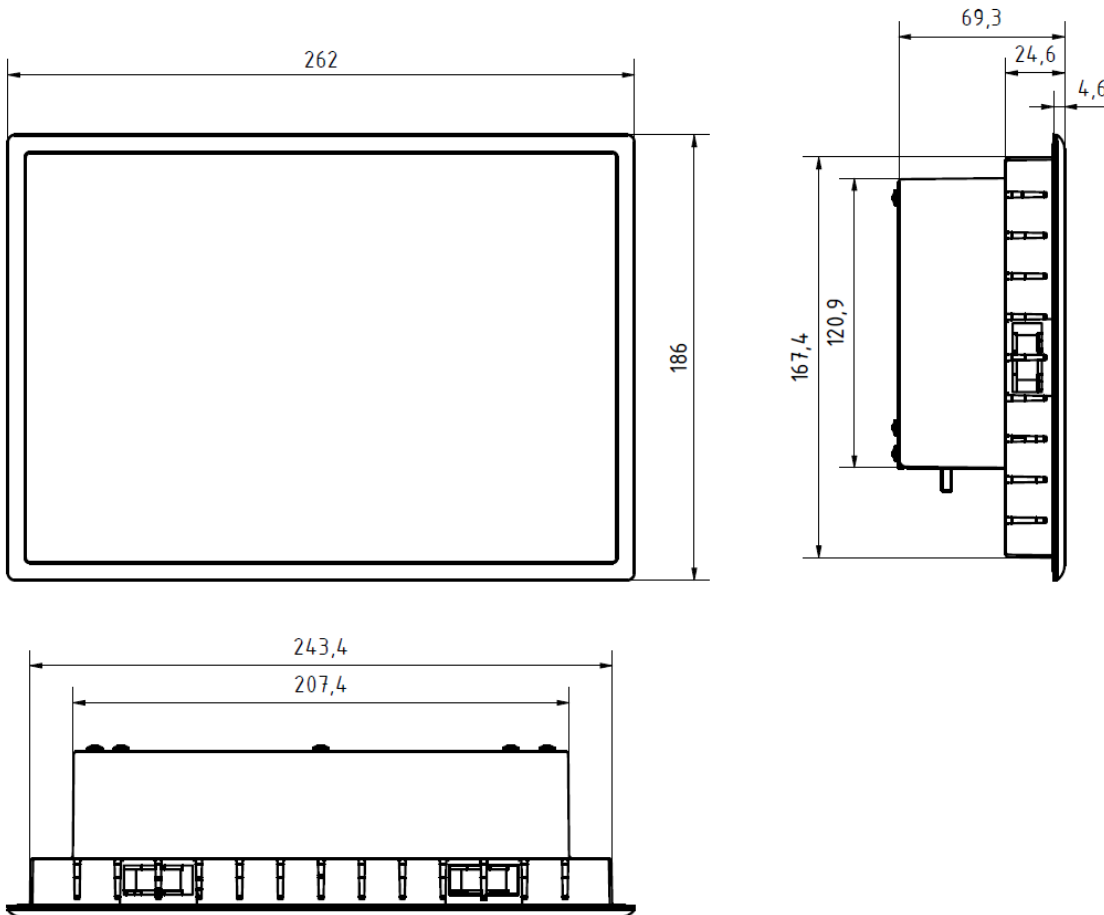

Fig. 5: Dimensions DC-Pi Prime 10

Requirements:

- To allow sufficient air circulation, it must be ensured that the device has a clear space of at least 20 mm all round at the rear.
- The carrier material for the mounting cut-out is sufficiently thick, flat and stable.

NOTE

Damage to the device!

Installation on uneven support material can lead to mechanical stresses and cracks in the front face or malfunctioning of the touch screen.

- ▶ Make sure that the mounting points of the device are all in a common plane, with no more than maximum ± 0.5 mm variation.

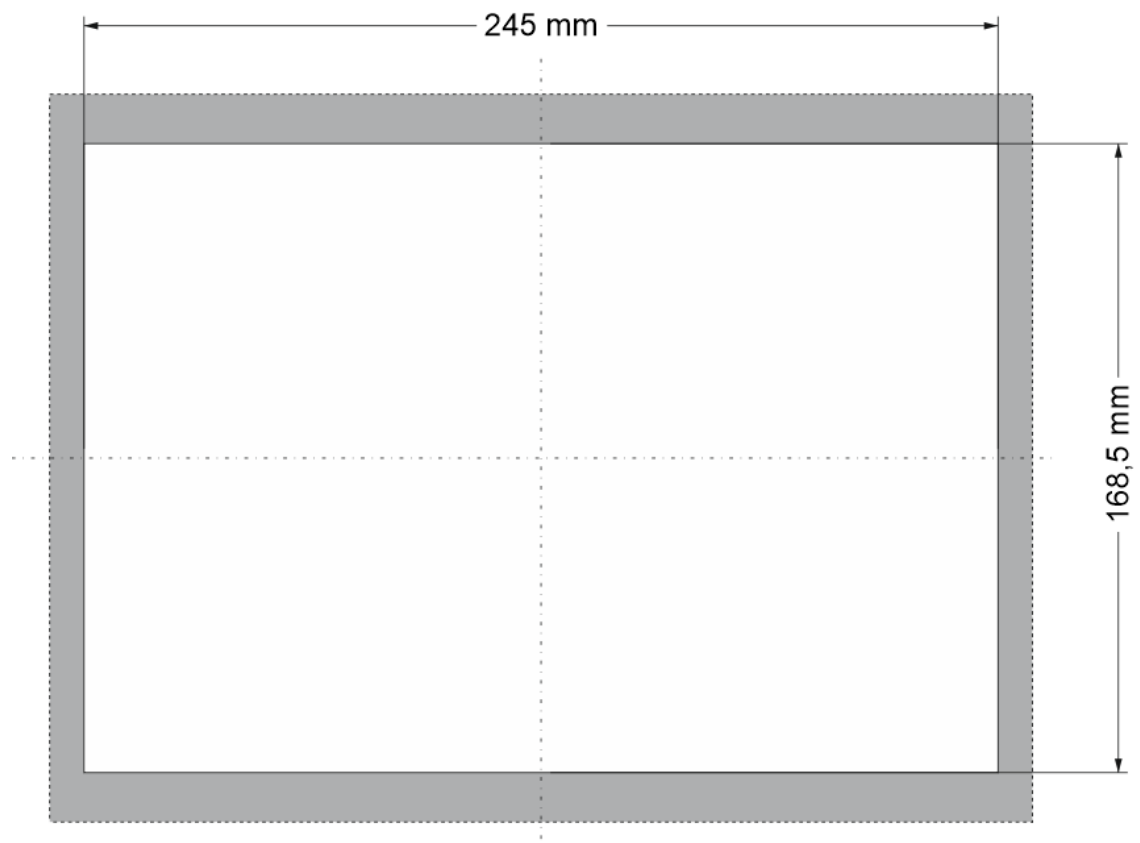

Fig. 6: DC-Pi Prime 10 mounting cut-out

- ▶ Cut a rectangular mounting cut-out from the backing material:
 Height: 168.5 mm
 Width: 245 mm
 Max. corner radius: 1.5 mm



Optimum thickness of the carrier material: 1.0 to 3.0 mm

4.3. Preparation for front installation DC-Pi Prime 15

The device is intended for installation from the front into a rectangular cut-out on a panel. The support material must be rigid and be from 1 to 3 mm thick.

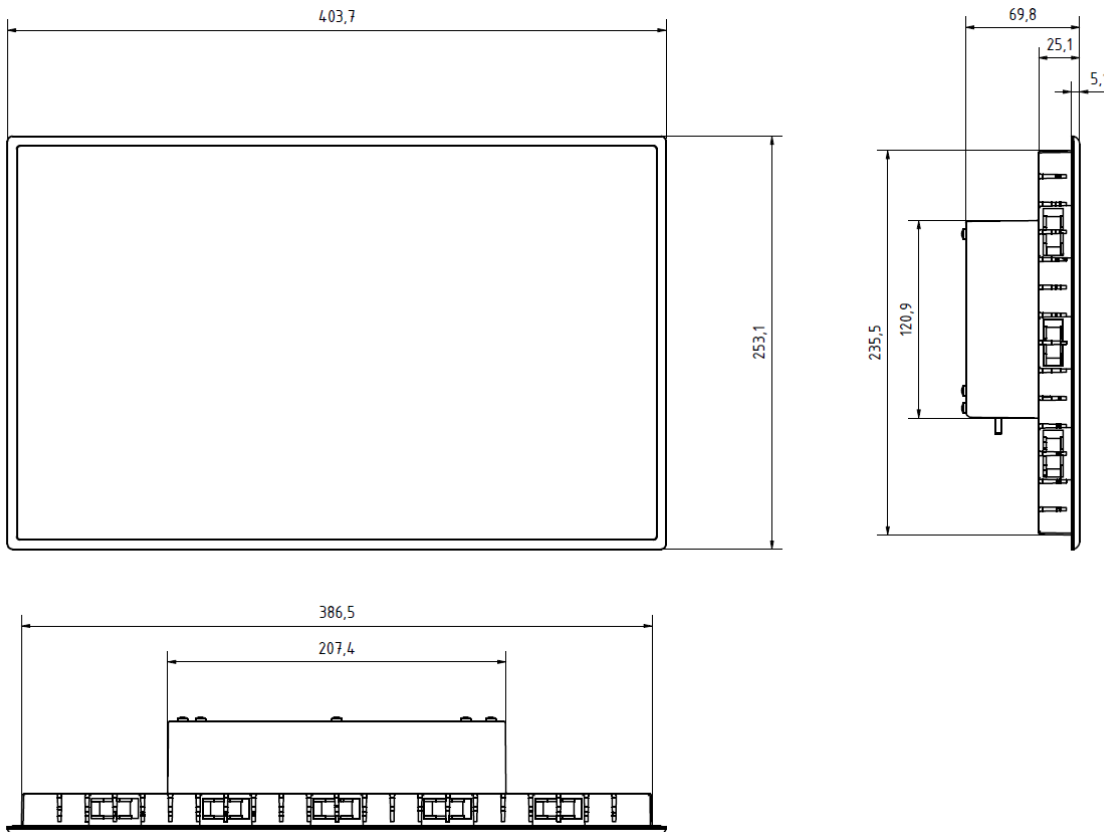

Fig. 7: Dimensions DC-Pi Prime 15

Requirements:

- To allow sufficient air circulation, it must be ensured that the device has a clear space of at least 20 mm all round at the rear.
- The carrier material for the mounting cut-out is sufficiently thick, flat and stable.

NOTE

Damage to the device!

Installation on uneven support material can lead to mechanical stresses and cracks in the front face or malfunctioning of the touch screen.

- ▶ Make sure that the mounting points of the device are all in a common plane, with no more than maximum ± 0.5 mm variation.

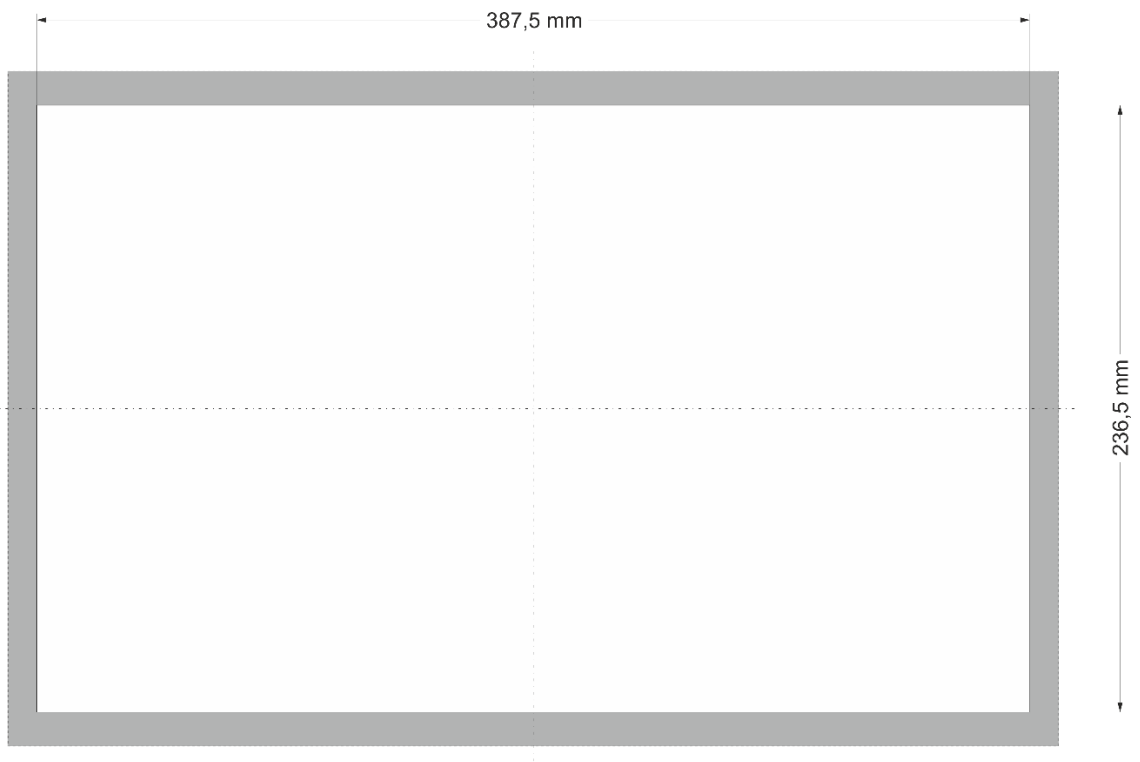

Fig. 8: DC-Pi Prime 15 mounting cut-out

- ▶ Cut a rectangular mounting cut-out from the backing material:
 Height: 236,5 mm
 Width: 387,5 mm
 Max. corner radius: 1.5 mm



Optimum thickness of the carrier material: 1.0 to 3.0 mm

4.4. Installation

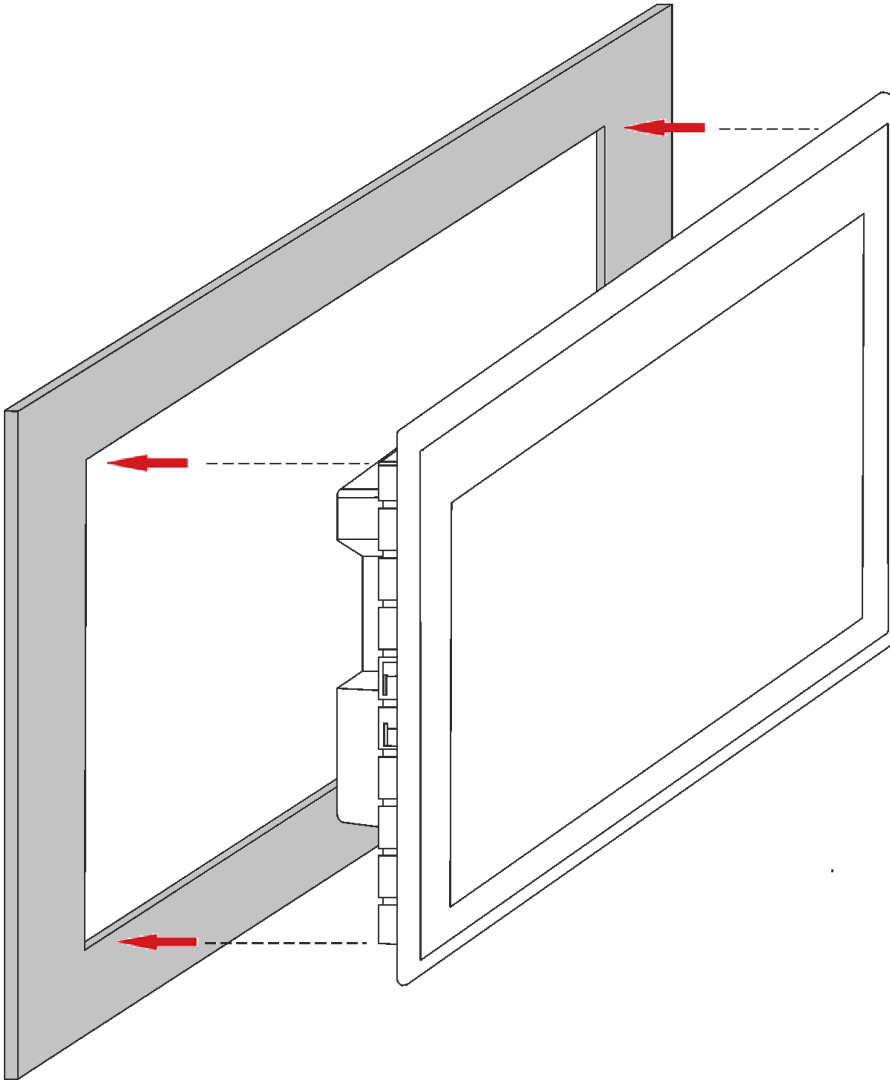

Fig. 9: Inserting into the mounting cut-out

Requirements:

- The securing clips must not be attached to the device.
1. Making sure the alignment is correct, push the device evenly into the installation cut-out.

NOTE

Damage to the device!

If installation is performed carelessly the device can fall out of the installation cut-out or be damaged.

- ▶ Do not tilt the device.
- ▶ Restrain the device against falling until the securing clips have been tightened.

2. Ensure that the device fits well all the way around.

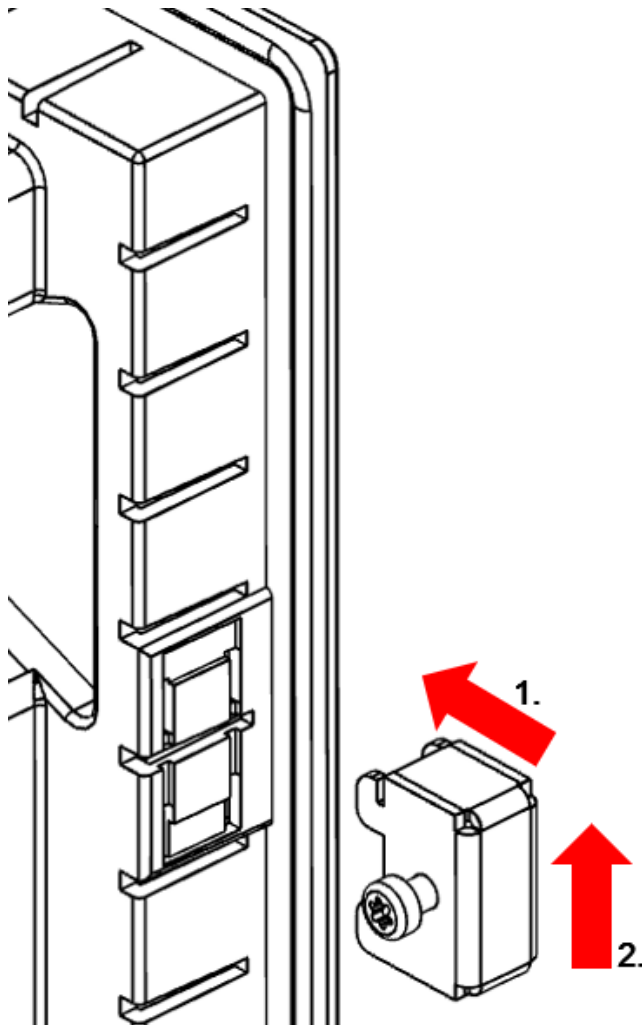
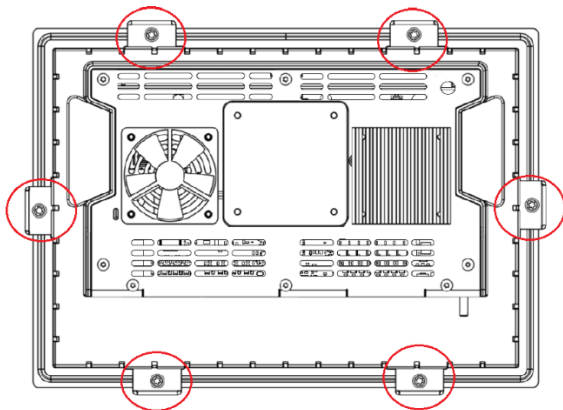
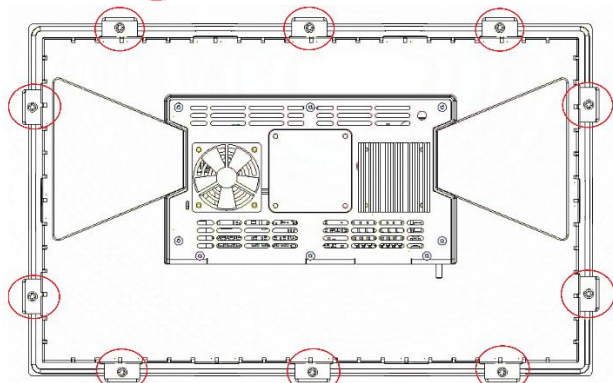

Fig. 10: Mounting the securing clips

3. Secure the device with 2 securing clips: Insert the securing clips into the cover at diagonally opposite points and tighten the screws finger-tight.



DC-Pi Prime 7 / 10



DC-Pi Prime 15

IP54: 10 securing clips,
standard features

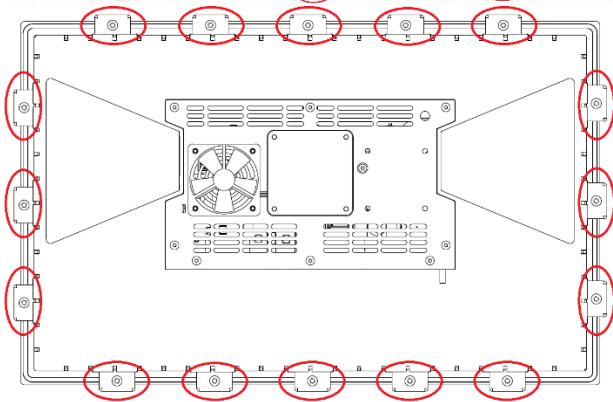

IP65: 16 securing clips,
expansion pack required:
order no. S-02060201-0100

Fig. 11: Fully tightening the securing clips

4. Insert the other securing clips and tighten the screws in all the securing clips equally (max 0,4 Nm).

DC-Pi Prime 7" / 10": 6x securing clip

DC-Pi Prime 15": 10x securing clip for IP54 / 16x securing clip for IP65

5. Connection

WARNING

Uncontrolled and unpredictable operational behaviour!

Failure of certain components in electronic control systems may result in uncontrolled and unpredictable operational behaviour.

- ▶ All types of failure and the associated protection systems must be taken into account at system level.
- ▶ Comply with all automation system manufacturer instructions.

5.1. Power supply

The device is powered by an external 24 V DC power supply.

- ▶ Before plugging in the device, ensure that the external power supply meets the required specifications (type K to 61131-2).

External power supply (24 V DC)

Supply voltage	+24 V DC SELV (-20 % / +25 %)
Ripple current proportion	Max. 5 % The DC voltage level must not fall below 20.4 V.
Power consumption	DC-Pi Prime 7: Total max. 0.8 A at +24 V DC (PLC internal) DC-Pi Prime 10: Total max. 0.8 A at +24 V DC (PLC internal) DC-Pi Prime 15: Total max. 1.2 A at +24 V DC (PLC internal) With optional digital & analogue extension additionally up to 4.2A at +24V DC (separate supply connection)

Installation

- ▶ Make all connections and cables in such a way that no interference from inductive and capacitive capacitive interference on the device.
- ▶ Ensure that the current and voltage resistance of the supply lines is sufficient.

5.1.1. Connecting the power supply

⚠ CAUTION

Live parts!

- ▶ Before starting any work on the device, switch off all power feeds, including peripherals.

DC-Pi Prime

- ▶ Connect the power supply to plug X1 according to the following table.

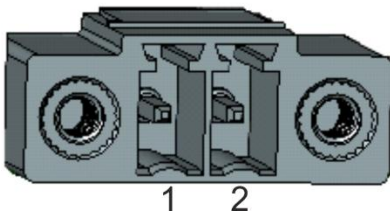

Fig. 12: Power supply X1

Power supply plug X1		
Pin	Description	Assignment
1	L0+	Supply 24 V DC (-20 %/+25 %)
2	L0-	GND 0 V DC

The following mating parts have been tested for the 15EDGRM-THR-3.5-02P-13-10Z (DEGSON) series connector and may be used with the device:

- **15EDGKNM-3.5-02P-13-1000Z (DEGSON)**

5.2. Data connections

5.2.1. Block diagram

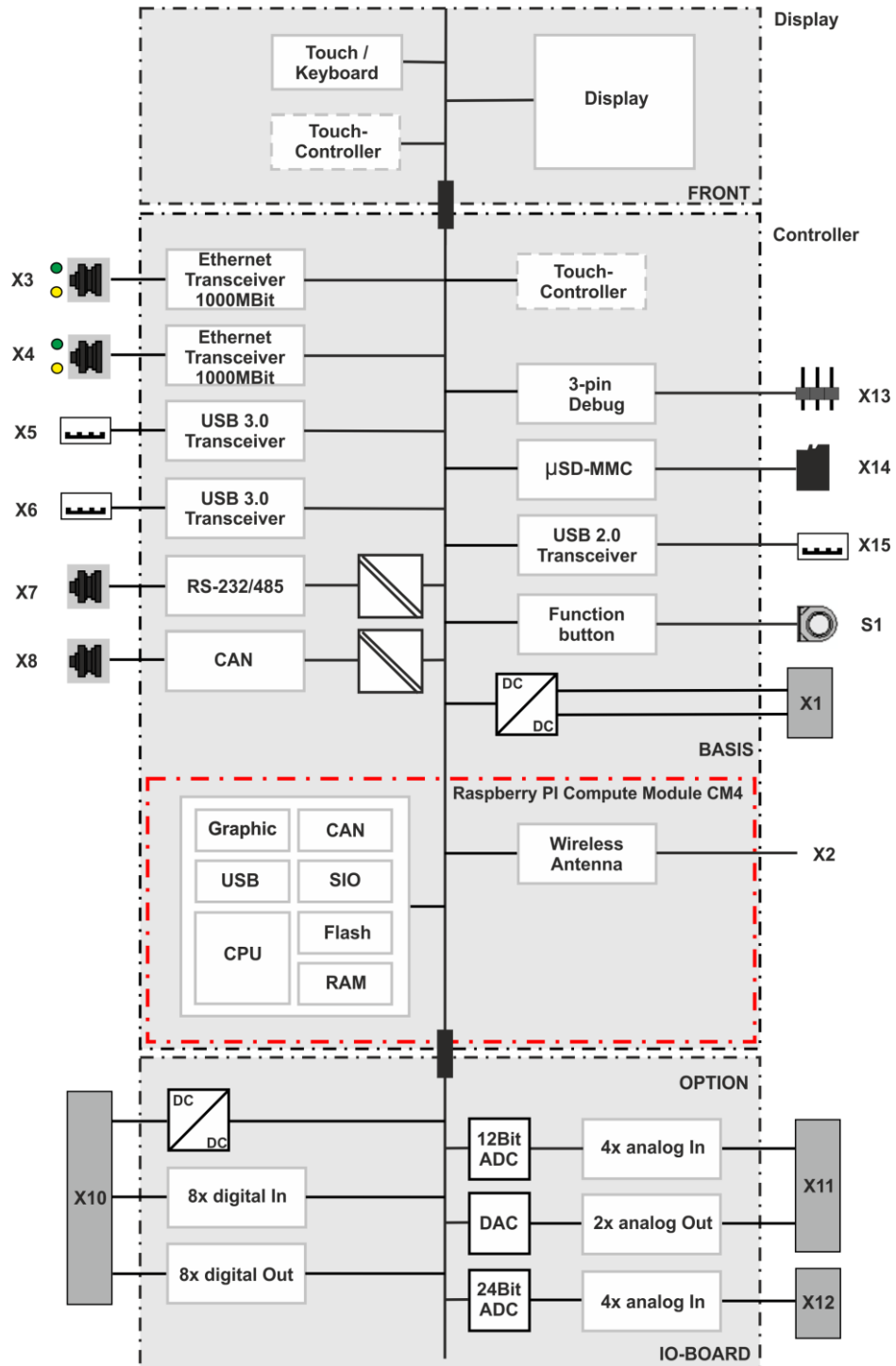

Fig. 13 : Block diagram DC-Pi Prime

5.2.2. Digital inputs and outputs

The digital outputs are positive-switching 24V outputs with an output current of max. 500 mA (per channel). They have a common reference potential (GND) to the supply voltage.

NOTE

Damage to the inputs or the device!

Voltages above ± 32 V can damage the inputs or the device.

- ▶ Do not apply a voltage exceeding ± 32 V to the inputs.

The digital inputs are positive switching inputs of type 1 or 3 (IEC 61131-2). They are designed for input voltages of nominally 24 V. The input signals are transmitted internally cyclically for process data processing. An open input is interpreted as static 0 (LOW). The inputs also have a common reference potential (GND).

The following mating parts have been tested for the plug connector 15EDGRHCM-THR-3.5-18P-13-1000Z (DEGSON) and may be used with the device:

- 15EDGKNHM-3.5-18P-13-00Z (DEGSON)

5.2.3. DC Pi Prime connector overview from version S02

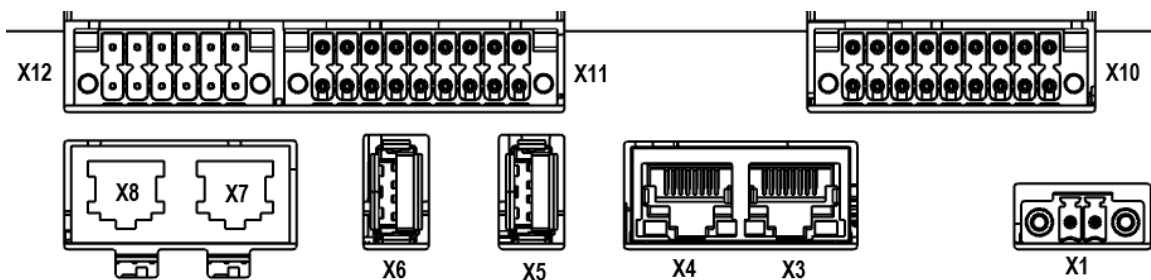

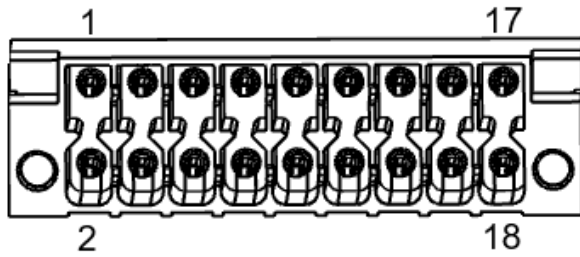

Fig. 14: Digital inputs and outputs X10

Digital inputs and outputs connector X10		
Pin	Ref.	Occupancy
1	DO 8	Digital output
2	DI 8	Digital input
3	DO 7	Digital output
4	DI 7	Digital input
5	DO 6	Digital output
6	DI 6	Digital input
7	DO 5	Digital output
8	DI 5	Digital input
9	DO 4	Digital output
10	DI 4	Digital input
11	DO 3	Digital output
12	DI 3	Digital input
13	DO 2	Digital output
14	DI 2	Digital input
15	DO 1	Digital output
16	DI 1	Digital input
17	+24V DC	Power supply (see "Power supply")
18	GND	Ground reference of the power supply

Data of the digital outputs		
Feature	Value	Description
Type of outputs	Semiconductors	Not storing, supplying current (plus switching)
Protective circuit for inductive loads	40 V clamping voltage (typ.) against +24 V	Fast excitation must be provided externally for large inductive loads
Status display	Yes	One yellow LED per output lights up at logic 1 (load side)
Overload protection	Yes	In the event of thermal overload, self-resetting
Short-circuit protection Response threshold	Yes	Electronic current limitation: typ. 4 A The current is limited electronically. Response of the short-circuit protection from at least 1.1 A leads to thermal overload and triggering of the thermal overload protection. Permissible limit values based on cold state: max. 10,000 short circuits, total duration max. 500 hours.
Status for unsafe operating states	Logical 0	If the supply voltage is insufficient and when the control system is started up or shut down, the outputs are set to logic 0.
Output delay Level change	typ. 200 µs	-
Signal delay on activation	typ. 1 ms	Cyclical, depending on the cycle time set in the programming system
Output capacity	< 20 nF	-
Rated voltage	+24 V DC	-
Voltage drop (at rated current)	< 0,5 V	-
Rated current with logic "1" signal	0,5 A	Rated current per channel
Total current of all outputs	max. 4 A	In the event of an overload, the digital outputs switch themselves off (overtemperature protection)
Parallel connection of two outputs	max. 1 A	Maximum permissible value for a logic operation to increase the power

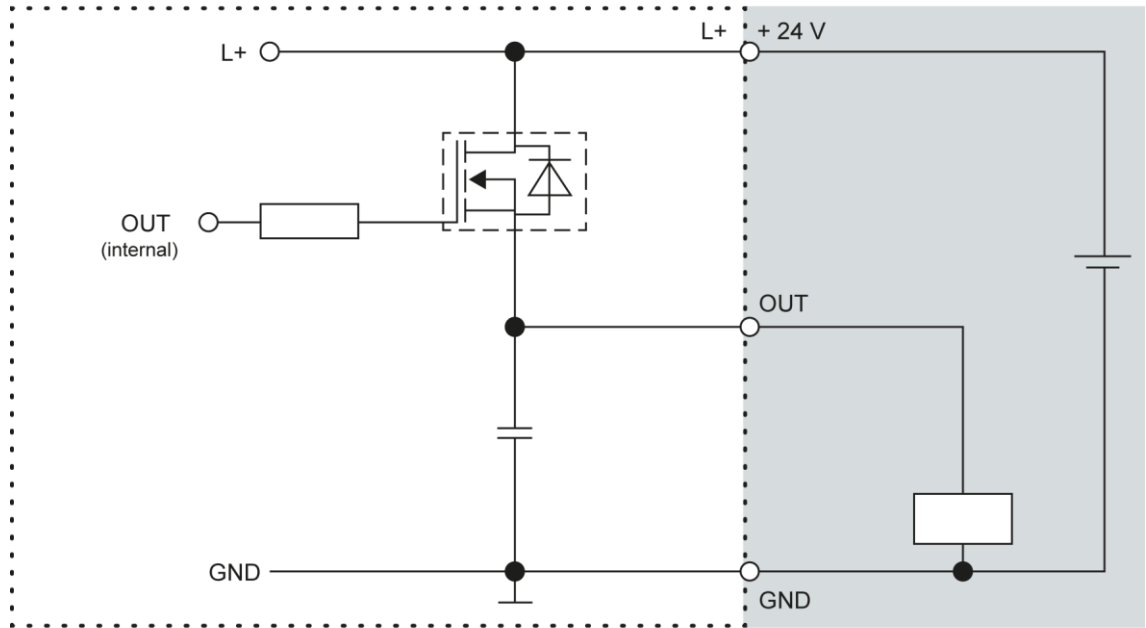

Fig. 15: Principle circuit diagram output, positive switching

Data of the digital inputs		
Feature	Value	Description
Type of inputs	Type 1 / 3	According to IEC 61131-2 Drawing current (positive switching)
Cable length	max. 30 m	For unshielded connection cables For cable lengths over 30 meters, the cables must be shielded.
Cable cross-section in the switch cabinet	0.14-1.5 mm ² (26-16 AWG)	Align to connectors with limits according to UL specifications.
Field wiring	according to regulations and standards	Fulfil all applicable local regulations and the requirements of DIN EN 61131-2.
Nominal load voltage	+24 V DC	-
Delay time	2.5µs	Applies to the transition from logical "0" to "1" and from logical "1" to "0"
Signal delay during evaluation	typ. 1 ms	Cyclical, depending on the cycle time set in the programming system
Polarity reversal protection	Yes	-
Potential separation	No	-
Status display	Yes	One yellow LED per input lights up at logic 1

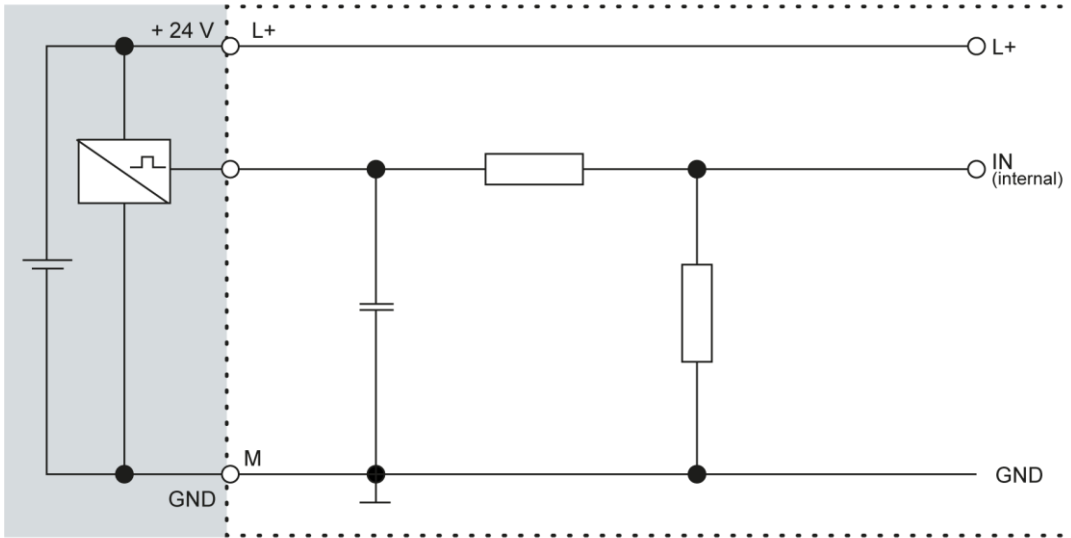

Fig. 16: Principle circuit diagram input, positive switching

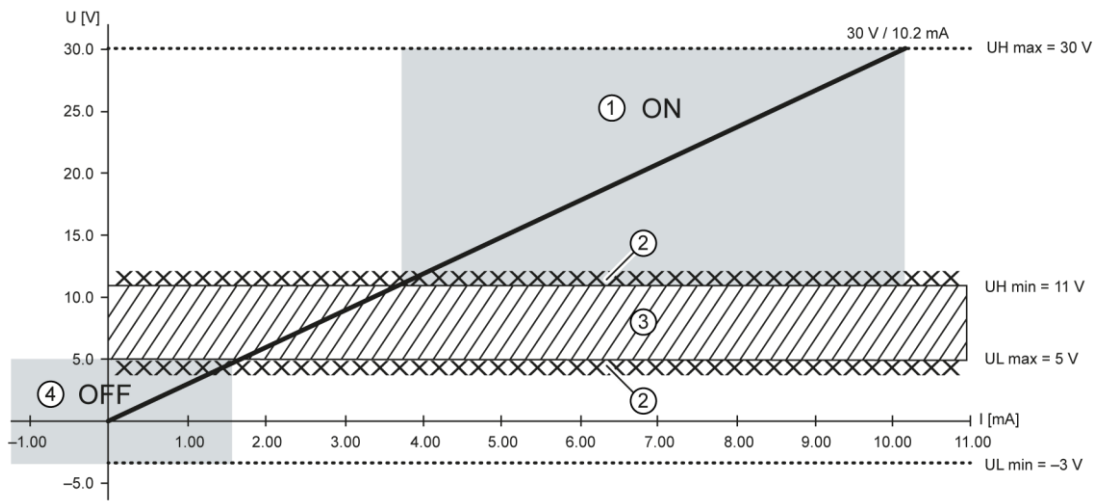

Fig. 17: Operating ranges of the digital inputs (type 1/3)

Pos.	Designation	Pos.	Designation
1	"ON" area	3	Transition area
2	Signal-to-noise ratio < 1 V	4	"OFF" area

5.2.4. Analog inputs and outputs

Basics for connecting the analogue inputs

- An analogue input channel always consists of two connections: input (AIN_U, AIN_I or AIN_UT) and AGND.
- The AIN_UT channels can either measure voltages or analyze PT100(0) sensors.
- Two associated AIN_UT channels can be used to compensate the lead resistances for PT100(0) measurements (3-wire measurement).
- The AIN_I and AIN_IT channels can only measure currents.
- The earth/ground/GND line of the current/voltage transmitter or temperature sensor connected to an analogue input may only be connected to AGND (not to GND or PE (earth)).
- AGND must not be connected to the general GND of the control cabinet or to "M" of the control unit (GND and AGND are already connected within the control unit and specially filtered).
- AGND must not be connected directly to the protective earth conductor (PE) of the machine or system.
- Long cables and cables with a small cross-section lead to deviations in voltage inputs and PT100(0) measurements (cable resistance). These unavoidable deviations must be taken into account when planning the wiring.
- To avoid interference, analogue I/O cables must be routed separately from digital signals and power-carrying conductors.
- Shielded cables are recommended for all analogue I/Os. The shield is connected to the sensor or encoder and in the switch cabinet or near the control unit.

The following counterparts have been tested for the plug connector 15EDGRHCM-THR-3.5-18P-13-1000Z (DEGSON) or 15EDGRHCM-THR-M3.5-12P-13-1000Z (DEGSON) and may be used with the device:

- **15EDGKNHM-3.5-18P-13-00Z(H) (DEGSON)**
- **15EDGKNHM-3.5-12P-13-00Z(H) (DEGSON)**

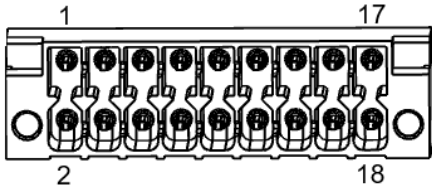

Fig. 18: Analogue inputs (U/I) / Analogue outputs (U) X11

Analogue inputs (U/I) / Analogue outputs (U) X11			
Pin	Occupancy	Pin	Occupancy
1	AIN_U4	2	AIN_I4
3	AGND	4	AGND
5	AIN_U3	6	AIN_I3
7	AGND	8	AGND
9	AIN_U2	10	AIN_I2
11	AGND	12	AGND
13	AIN_U1	14	AIN_I1
15	AGND	16	AGND
17	AOUT_U1	18	AOUT_U2

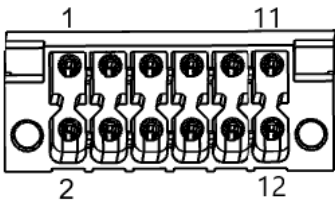

Fig. 19 : Analogue inputs (U/I/PT) X12

Analogue inputs (U/I/PT) X12			
Pin	Occupancy	Pin	Occupancy
1	AIN_UT4	2	AIN_IT4
3	AGND	4	AGND
5	AIN_UT3	6	AIN_IT3
7	AIN_UT2	8	AIN_IT2
9	AGND	10	AGND
11	AIN_UT1	12	AIN_IT1

Data of the analogue inputs (both resolutions)

Data of the analogue inputs		
Feature	Value	Description
Cable length	max. 30 m	Applies to unshielded connection cables. For cable lengths over 30 meters, the cables must be shielded.
Common points between the channels / Reference potential	AGND	Reference for measurement of all channels at the common AGND reference
Sampling duration/sampling rate for measured values	1 ms	Each input channel is sampled once every millisecond, regardless of how many channels are in operation.
Conversion time PT operating mode	250 ms	In PT mode, calculations are carried out after the calculations are performed after the sampling duration. A new value is only available in the application program every 250 ms.

Digital filtering		
Possible filter settings	Time range for averaging	Time range for averaging Operating mode AI-PT
1	1 ms	0,25 s
10	10 ms	2,5 s
100	100 ms	25 s
1000	1000 ms (1 s)	250 s

If filtering is activated, an average value is formed over the set time range. A value is still output at the sampling rate interval. If, for example, the filter is set to 1000, the average value from the measurements of the last 1000 ms / 1000 measurements is output every millisecond (or the average value from the last 250 s / 1000 measurements every 250 ms in AI-PT operating mode).

Filtering can be activated and configured via CODESYS. The sampling rate is constant. Filtering can only be performed using an integer multiple of the sampling rate.

Operating modes of the analogue inputs with 12-bit resolution

NOTE

Damage to the duct!

A voltage that is too high or too negative can damage the analogue input and render it inoperative.

- ▶ Ensure that the input voltage remains in the range -1V...+15V.

Operating mode voltage input AIN (U) of the analogue inputs (U/I) X11

Feature	Value	Description
Number of inputs	4	Four separate measuring channels each between AIN_U and AGND. Only one operating mode can be used per measuring channel (U or I).
Conversion method	-	Dual slope (switched capacitor)
Measuring range	0...+10 V	-
Input impedance in the signal range	162 kΩ	between AIN_U and AGND Value applies when channel is switched on or off
Input type	-	Voltage measurement unbalanced (single ended)
Max. Error at 25 °C	±0.75 % (±75 mV)	Largest statistically determined measurement deviation
Temperature coefficient	±22 ppm / K (±0.22 mV / K)	related to full scale value
Digital resolution	12 bit	-
Value of the least significant bit	805.6 μV	-
Data format in application program	32 bit real	(floating point number) in the unit millivolt (mV)
Highest permissible continuous overload	Max. +12 V against AGND	+12 V = max. voltage on AIN channel
Output of the digital value in the event of overload	-	If a voltage greater than +10 V is applied to an AIN (U), a plausible value is still output up to approx. +12 V. The specified accuracy only applies to the range 0...+10 V. If voltages greater than +15 V are applied, the internal ADC may be damaged
Dynamic properties		

Operating mode voltage input AIN (U) of the analogue inputs (U/I) X11		
Feature	Value	Description
Analogue filtering	2nd order low-pass filter, cut-off frequency 240 Hz	-
Largest temporary deviation during electrical interference test according to IEC 61131-2	1.5 % of the measuring range	-

Operating mode current input AIN (I) of the analogue inputs (U/I) X11		
Feature	Value	Description
Number of inputs	4	Four separate measuring channels each between AIN_I and AGND. Only one operating mode can be used per measuring channel (i.e. either U or I).
Measuring range	0...+20 mA	Technical current direction into AIN_I
Input impedance in the signal range	Type. 50 Ω	between AIN_I and AGND Value applies when channel is switched on or off
Input type	-	Current measurement unbalanced (single ended)
Max. Error at 25 °C	±0.6 % (±120 µA)	Largest statistically determined measurement deviation
Temperature coefficient	±22 ppm / K (±0.44µA / K)	related to full value
Data format in application program	32 bit real	(floating point number) in the unit milliampere (mA)
Highest permissible continuous overload	Max. 42 mA against AGND	+42 mA = max. current on AIN channel
Output of the digital value in the event of overload	-	If a current greater than +20 mA is applied to an AIN_I, a plausible value is still output up to approx. +24 mA. The specified accuracy only applies to the range 0...+20 mA. If currents greater than +42 mA are applied, the measuring resistor may be damaged

Dynamic properties		
Analogue filtering	2nd order low-pass filter, cut-off frequency 180 Hz	-

Operating mode current input AIN (I) of the analogue inputs (U/I) X11

Feature	Value	Description
Largest temporary deviation during electrical Interference test according to IEC 61131-2	1.5 % of the measuring range	-

Operating mode voltage input AIN (U) of the analogue inputs (U/I/PT) X12

Feature	Value	Description
Number of inputs	4	Four separate measuring channels each between AIN_UT and AGND. Only one operating mode can be used per measuring channel (i.e. either U or T)
Conversion method	-	Delta-sigma conversion
Measuring range	-10...+10 V	-
Input impedance in the signal range	100 kΩ	between AIN_UT and AGND Value applies when channel is switched on or off
Input type	-	Voltage measurement symmetrical (differential)
Max. Error at 25 °C	±0.16 % (±16 mV)	Largest statistically determined measurement deviation
Temperature coefficient	±48 ppm / K (±0.48 mV / K)	
Digital resolution	24 bit	-
Data format in application program	32 bit real	(floating point number) in the unit millivolt (mV)
Highest permissible continuous overload	Max. ±30 V against AGND	±30 V = max. voltage on AIN channel
Output of the digital value in the event of overload	-	If a voltage greater than ±10 V is applied to an AIN_UT, a plausible value up to approx. ±15 V is still output. The specified accuracy only applies to the range -10...+10 V. If voltages greater than ±16 V are applied, the values are greatly distorted.
Dynamic properties		
Analogue filtering	2nd order low-pass filter, cut-off frequency 650 Hz	-

Operating mode voltage input AIN (U) of the analogue inputs (U/I/PT) X12		
Feature	Value	Description
Largest temporary deviation during electrical interference test according to IEC 61131-2	1 % of the measuring range	-

Operating mode current input AIN (I) of the analogue inputs (U/I/PT) X12		
Feature	Value	Description
Number of inputs	4	Four separate measuring channels each between AIN_IT and AGND Only one operating mode can be used per measuring channel (U, I or T)
Measuring range	-20...+20 mA	Technical current direction into AIN_IT
Input impedance in the signal range	Type. 10 Ω	between AIN_IT and AGND Value applies when channel is switched on or off
Input type	-	Current measurement symmetrical (differential)
Max. Error at 25 °C	±0.25 % (±50µA)	Largest statistically determined measurement deviation
Temperature coefficient	±60 ppm / K (±1.2 µA / K)	related to scale value
Data format in application program	32 bit real	(floating point number) in the unit milliampere (mA)
Highest permissible continuous overload	Max. ±25 mA against AGND	-
Output of the digital value in the event of overload	-	If a current greater than ±20 mA is applied to an AIN_I, a plausible value is still output up to approx. ±25 mA. The specified accuracy only applies to the range -20...+20 mA.

Dynamic properties		
Analogue filtering	2nd order low-pass filter, cut-off frequency 600 Hz	-
Largest temporary deviation during electrical interference test according to IEC 61131-2	1 % of the measuring range	-

Operating mode Temperature inputs AIN (PT) of the analogue inputs (U/I/PT) X12

Feature	Value	Description
Number of inputs	4 (2)	Sensor connection between AIN_UT and AGND. Only one operating mode can be used per measuring channel (U, I or T). (Two AIN_UT channels are used for 3-wire measurement).
Possible sensors	PT100 and PT1000 according to EN 60751	Platinum sensors of accuracy classes AA, A, B and C can be used
Measuring range	-40...+200 °C	-
Measuring current (RMS)	0.6 mA (±0.1%)	-
Conversion time	250 ms	-
Max. Error at 25 °C	±2100 ppm (±0.5 °C)	-
Temperature coefficient	±50 ppm/K (±0.012 °C/K)	-
Digital resolution	24 bit	-
Data format in application program	32 bit real or 32 bit float	Floating point numbers in the units Ohm (Ω) and Degree Celsius (°C)
Linearisation	-	The value in degrees Celsius is calculated from the resistance value and linearised (6th degree polynomial)
Input type	-	2-wire measurement or 3-wire measurement of the platinum temperature probes
Reference potential	AGND	common for all inputs
Dynamic properties		
Analogue filtering	2nd order low-pass filter, cut-off frequency 650 Hz	-
Largest temporary deviation during electrical interference test according to IEC 61131-2	1 % of the measuring range	-

Data of the analogue outputs

Operating mode of the analogue outputs (AOUT) X11		
Feature	Value	Description
Protective device	Thermal overload protection, (short-circuit proof)	Current limitation from approx. 22 mA (at 25 °C ambient temperature)
Insulation voltage between channel and other circuits	None	-
Cable length	max. 30 m	Applies to unshielded connecting cables. Shielded cables must be used for cable lengths over 30 m.
Common points between the channels	AGND	AGND is the reference potential for all analogue outputs
Permitted load types	-	Resistive and capacitive loads
Largest capacitive load	10 µF	Larger capacitive loads can cause the output to oscillate.
Max. Terminal voltage	12 V	A voltage of more than 12V can damage the analogue outputs.
Signalling range	0...10 V	-
Load impedance range	> 1 kΩ	(or burden)
Output current	Max. 10 mA	-
Max. Error at 25 °C	±0.25 % (±25 mV)	-
Temperature coefficient	±50 ppm / K (±0.5 mV / K)	-
Value of the least significant bit (LSB)	±291 ppm (±2.91 mV)	-
Digital resolution	12 bit	-
Data format in the user program	32 bit real	floating point number in the unit millivolt (mV)
Dynamic properties		
Settling time when changing over the full range to 95 % of the final value	typ. 400 µs	-
Overshoot	Up to 1% of the measuring range	typ. < 0.25 % of the measuring range

Operating mode of the analogue outputs (AOUT) X11

Feature	Value	Description
Largest temporary deviation during electrical interference test according to IEC 61131-2	Up to 1% of the measuring range	-

Output response of the analogue outputs (AOUT) X11

Without supply voltage	AOUT (U) to AGND: < 40 Ω	Low-resistance output
During the boot process of the device	-	The analogue output is not yet active while the device is booting. Deviations from the zero value when switching on are ≤ 1 % of the signal range
For short-term interruptions	-	If the supply voltage is interrupted for > 10 ms, the analogue outputs are switched off.

Behavior in stop mode

Voltage output	-	Can be configured in CODESYS. Either the last valid value is retained or 0 V is output.
----------------	---	---

5.2.5. Connection examples

Voltage output AO (U) on X11

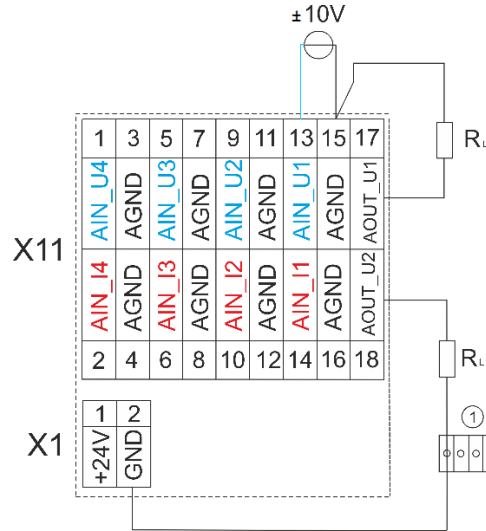

Fig. 20: Connection example: Voltage output AO (U)

Pos.	Description
1	Terminal strip

- ▶ If possible, connect the voltage outputs directly via the load impedance R_L to the AGND of the I/O extension.
If it is not possible to connect directly to AGND: Connect the voltage output to the general GND of the device.
- ▶ Ensure that the line resistances are significantly lower than the load impedance R_L in order to achieve a high output accuracy.
- ▶ Observe the voltage divider between load and line resistance, as well as the input resistance of the measuring device when measuring back.

Voltage input AIN (U) on X11

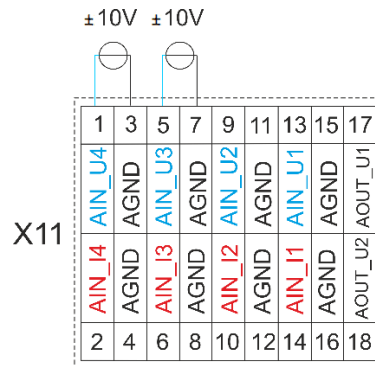

Fig. 21: Connection example: Voltage input AIN_U

- ▶ If possible, only use the nearest AGND for each voltage input.
- ▶ Do not connect AGNDs of several channels. Reverse currents can influence the measurement.
- ▶ Only use one function per channel - either AIN_U or AIN_I.
- ▶ Do not establish a connection to the general GND. The necessary and filtered connections are already available on the circuit board.
- ▶ Lay the cables of the analogue sensors/encoders as directly as possible and without detours (avoid intermediate terminals and terminal strips).

Current input AIN (I) on X11

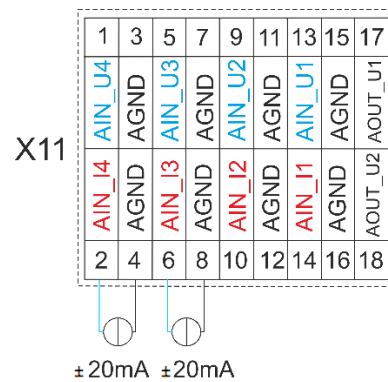

Fig. 22: Connection example: Current input AIN_I

- ▶ If possible, only use the nearest AGND for each power input.
- ▶ Do not connect AGNDs of several channels. Reverse currents can influence the measurement.
- ▶ Only use one function per channel - either AIN_U or AIN_I.
- ▶ Do not establish a connection to the general GND. The necessary and filtered connections are already available on the circuit board.
- ▶ Lay the cables of the analogue sensors/encoders as directly as possible and without detours (avoid intermediate terminals and terminal strips).

Temperature measurement AI (PT)

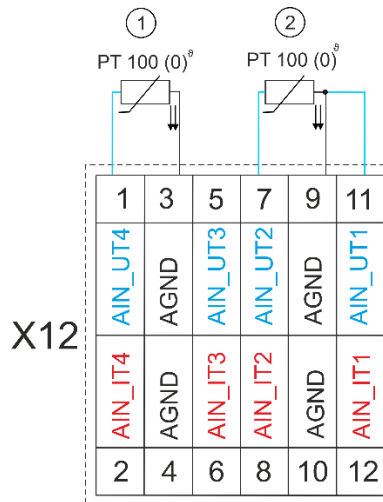

Fig. 23: Connection example: Temperature measurement

Pos.	Description
1	PT 100 with 2-wire connection
2	PT 100 with 3-wire connection

- ▶ Only use the corresponding AGND for each input.
- ▶ Do not connect AGNDs of several channels. Reverse currents can influence the measurement.
- ▶ Do not establish a connection to the general GND. The necessary and filtered connections are already available on the circuit board.
- ▶ If possible, lay the PT100 or PT1000 sensor cables directly and without detours (avoid intermediate terminals and terminal strips).
- ▶ Only connect PT100 or PT1000 sensors to the AIN_UT channels.

2-wire measurement

The cable resistance results in a measurement error that can be up to 10 Kelvin for long cables and small cable cross-sections. If the temperature of the sensor is known, this deviation can be subtracted and compensated for via the software (alternatively, realize the connection using 3-wire measurement).

3-wire measurement

The nearest connection AIN_UT is used to compensate for the line resistance. Only the channel directly following the AIN_UT can be used. Channels 1 and 2 as well as channels 3 and 4 are each a suitable pair for 3-wire measurement.

5.2.6. Ethernet

The onboard Ethernet adapter has two 10/100/1000-Base-T RJ-45 ports for connection to the network. The Ethernet interface X3 and X4 can be used as a standard Ethernet interface.

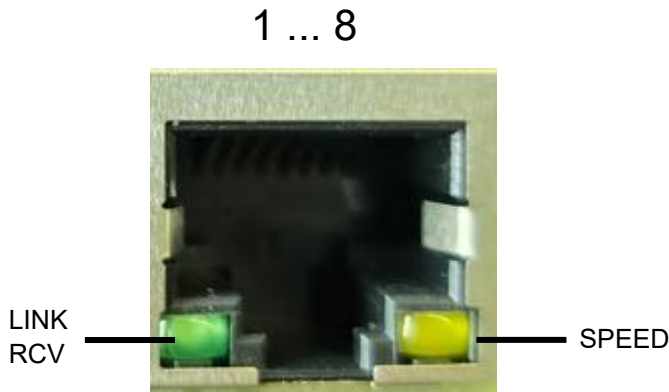

Fig. 24: Ethernet interface X3 and X4

Assignment of Ethernet interface connector X3 and X4			
Pin	Occupancy	Pin	Occupancy
1	BI_DA+ Bidirectional pair A+	5	BI_DB- Bidirectional pair B-
2	BI_DA- Bidirectional pair A-	6	BI_DC- Bidirectional pair C-
3	BI_DB+ Bidirectional pair B+	7	BI_DD+ Bidirectional pair D+
4	BI_DC+ Bidirectional pair C+	8	BI_DD- Bidirectional pair D-

LEDs		
LED	Colour	Meaning according to IEEE 802.3 clause 25
LNK/RCV	Green	Link, Data Receive Flashing: connection active; data transfer in progress Off: no connection established
SPEED	Yellow	On = 1000 Mbit/s On = 100 Mbit/s Off = 10 Mbit/s

5.2.7. USB

Devices with a USB interface can be connected to the two USB host ports.



Fig. 25: USB interfaces X5 and X6

NOTE

Damage to USB stick and malfunction due to data loss!

Removing a USB stick while it is still in use and data is being transferred can render the USB stick unusable. Open files which can no longer be accessed because the USB stick has been removed can block the device.

- ▶ Therefore, ensure that all operations are complete before removing the USB stick.

NOTE

Damage to property and malfunctions due to data loss!

The USB interface is protected against overloading (see USB interfaces max. current → p. 68). In the event of a short circuit during operation, the control unit may trigger a reset of the system.

Substantial property damage and damage to the USB device may ensue.

- ▶ Before using a USB device, check carefully its power requirements.

NOTE

Failures and malfunctions will occur if direct connections are made to signal earth!

- ▶ Use only USB devices that have no direct connection between signal earth and the housing



The USB interface plug is designed to withstand 1,000 plugging and unplugging cycles.

5.2.8. CAN bus

Properties of the CAN interface X8	
Standard	ISO 11898
Maximum baud rate	1 MBit/s
Lowest adjustable baud rate	50 kBit/s
Contacts	Galvanically isolated
Occupancy	according to CiA303

1 ... 8

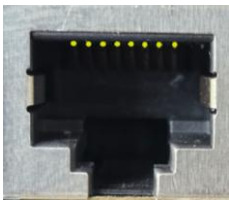

Fig. 26: CAN interface X 8

Assignment of CAN interface connector X8			
Pin	Assignment	Pin	Assignment
1	CAN_H	5	NC
2	CAN_L	6	NC
3	ISO GND	7	ISO GND
4	NC	8	NC

If the CAN interface is at the beginning or end of the CAN bus topology:

- Set switch S2 to ON to switch on the terminating resistor of 120 Ω between CAN_L and CAN_H.

Switch position

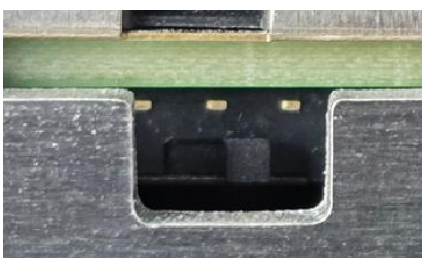

OFF ON

5.2.9. Serial interfaces

The module has two serial communication interfaces (1x RS-232 and 1x RS-485), which are connected via the common RJ45 connector X7.

Maximum baud rate of both interfaces: 115.2 kBit/s

1 ... 8

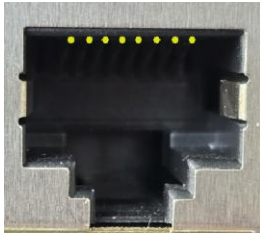

Fig. 27: RS-232 / RS-485 interface X7

Assignment RS-232 / RS-485 interface connector X7			
Pin	Assignment / software interface	Pin	Assignment / software interface
1	RS-232 RX / COM1	5	RS-485 Tx/Rx- / COM2
2	RS-232 TX / COM1	6	NC
3	NC	7	(reserved)
4	RS-485 Tx/Rx+ / COM2	8	ISO GND

The RS-485 interface is "softly" terminated with 680 Ω (polarization).

If the interface is at the beginning or end of the bus topology:

- ▶ Set switch S3 to ON to switch on the differential terminating resistor of 120 Ω

Switch position

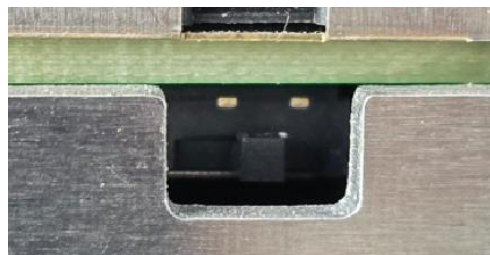

OFF

ON

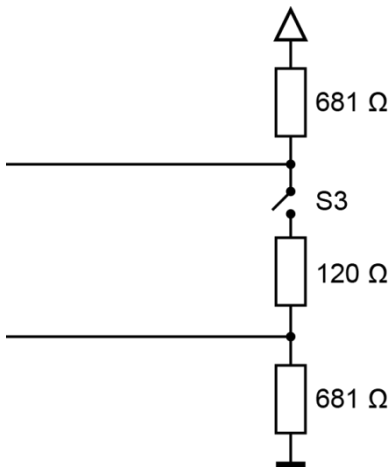

Fig. 28: RS-485 switchable terminating resistor

i The assignment of the interface is largely based on the specifications of the "MODBUS over Serial Line; Specification and Implementation Guide V1.02".

Signal interference and terminating resistor

The following instructions must be observed to minimize interference.

Driven bus

- A suitable protocol must ensure that one of the bus participants is actively driving the bus at all times.
- For a high symmetrical signal-to-noise ratio, the bus must have defined states for logic "1" ($A-B < -0.2\text{ V}$) and for logic "0" ($A-B > +0.2\text{ V}$).

Unpowered bus

- A bus termination that is as unbalanced as possible must ensure a sufficiently large signal-to-noise ratio (reduce the balanced signal-to-noise ratio).
- In order to achieve the necessary voltage difference between the signals, a suitable resistor network must be used as a line termination.
- The required values of the resistors depend on the bus length and transmission rate (similar to the line termination for Profibus, see DIN EN 61158-2).

Connections with GND

To minimize common mode interference or malfunctions due to potential differences:

- ▶ Check the topology and cable lengths to see whether additional connections with GND are necessary.
- ▶ For electrically isolated interfaces with connection to the reference earth at one point: Carry GND.
- ▶ If required, ensure a damped connection of GND at several points on the bus (e.g. via 200 Ω).

6. Operation

6.1. Switching on and off

NOTE

Damage or malfunction!

- ▶ Do not insert, connect, undo or touch any connections whilst the device is in operation.
- ▶ Before starting any work on the device, switch off all power feeds, including those to any connected peripherals (sensors and programmable devices etc. with independent power supplies).

NOTE

Damage to property!

- ▶ Before connecting the power supply, ensure that all cabling and the polarity of all the connections are correct.

Switch on

The device does not have an on/off switch. The device starts automatically when the system is switched on or the power is connected.

Switch off

The device is switched off when the system is switched off or the power supply is disconnected.

6.2. Initial Setup of the device

6.2.1. Web interface configuration

Before the device can be used, it must be integrated into the network with the correct configuration.

NOTE

Material damage!

- ▶ Before applying the supply voltage, check the correct wiring and polarity of all connections.

1. Supply the device with power (+ 24 V DC).
After starting, the current IP address and netmask of the device are shown at the bottom right of the display.
2. Connect the device to a programming computer via network cable (X3) and network switch.
3. Open the web browser on the programming computer.
4. https:// Enter the IP address of the device in the web browser.

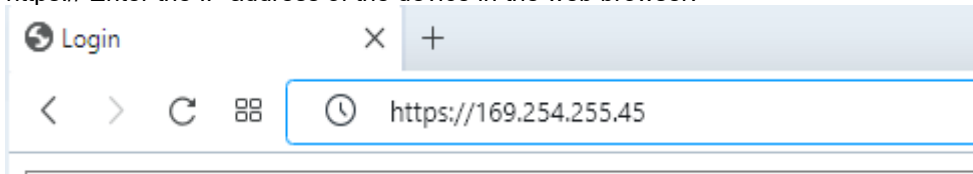

Depending on the browser used, a warning about an unrecognized connection is displayed. This connection must be trusted manually in the browser

The login window appears.



User Login:

Name:

Password:

Fig. 29: Login window

5. Name: admin
The default password, which is printed on the device label, is used as the password.

NOTE

Device password

To prevent attacks and comply with cyber security change password on initial commissioning

- ▶ Change password according to password guidelines.

The web configuration is displayed.

Configuration

- [Network](#)
- [Time and Date](#)
- [FTP-Server](#)
- [SSH-Server](#)
- ▶ [WEB-Server](#)
- [VPN](#)
- [IXON](#)
- [Users](#)
- ▶ [WEB-Browser](#)
- [Reset Config](#)

System

- [Info](#)
- [Licenseinfo](#)
- [Update](#)
- [Reboot](#)

PLC-Manager

- [Control](#)
- [Config](#)
- [Application Info](#)
- [Application Files](#)

Fig. 30: List of settings in the web interface

6. Click on the "Network" link.
The "Network Configuration" page is displayed.

Network Configuration

COMMON

Hostname

DNS Server 1

DNS Server 2

ETH0

Mode:

IPAddress

NetMask

Gateway

ETH0:1

Mode:

ETH1

Mode:

Fig. 31: "Network Configuration" page

7. Check the network settings and change them in the respective text fields if required.
8. Save the settings with "Save".
9. If required, call up and change other settings in the web configuration (e.g. "Time and Date", "SSH server", "Web server").
10. To apply all changed settings, restart the device:
Briefly disconnect the device from the power supply.
- or -
Click on "Reboot" in the web interface and confirm with "Reboot Module" in the following window.

The device is configured and ready for use.

6.3. Operation

6.3.1. Status indicators

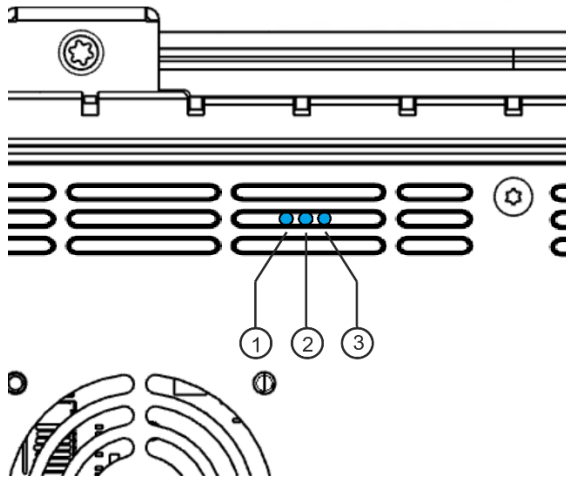

Fig. 32: Positions of the operating status LEDs

Status LED

The current status of the power supply, module mode and error messages are displayed via 3 operating status LEDs.

LED		Logical state
1	PWR (blue)	ON = correct supply voltage for the module electronics
2	Run/Stop	Indicates the state of the PLC application.
3	Error (red)	Indicates error stop.

RUN/STOP ERROR - LED signaling

There are 2 LEDs on the module for signaling the system state (RUN/STOP multi color: red/green/yellow; ERROR single-color red). The following system states are signaled via the LEDs:

System states	LED RUN/STOP	LED ERROR
Firmware, USB package update or service mode active	Yellow flashing	From
System error	From	Red
PLC states		
RUN	Green	From
STOP	Red	From
Error stop	Red	Red
Reset button detected	Flashing red	From
Applicative states		
Identification PROFINET Device	Yellow flashing	Flashing

Basic procedure for error stop:

- Determine cause of error (read via web browser)
- Eliminate the cause of the error
- Perform a reset on the control unit, alternatively: operating mode selector switch / CODESYS / web browser
- Putting the control unit back into operation

6.3.2. Real-time clock with voltage buffer

The DC-Pi series is equipped with a real-time clock. The buffer time is 30 days.

Set date/clock

The clock can be set either via the web configuration or via a CODESYS library.

6.3.3. µSD- card

WARNING

Serious injuries due to unregulated, unpredictable operating procedures!

Inserting or removing the µSD card can lead to malfunctions in the device. Malfunctions in electronic control systems can lead to an uncontrolled and unpredictable operating sequence.

- ▶ Only insert or remove a µSD card when the device is switched off.

Insert µSD card

1. Switch off the device.
2. Insert the µSD card into the µSD card slot.
3. Switch the device on again.

The μ SD card is ready for data transfer (writing, reading and copying).
 Path: /media/sd

NOTE

Suitable μ SD cards

The device supports all SDHC and SDXC μ SD cards from variant S02 onwards



Maximum possible storage capacity of a μ SD card 2 TB.
 The service life of the gold-plated contacts is up to 10,000 mating cycles.
 The μ SD card drive has a push-in/push-out plug-in and eject mechanism.
 To avoid malfunctions, the μ SD card must not be removed by pulling it out.

6.3.4. Start/stop reset button S1

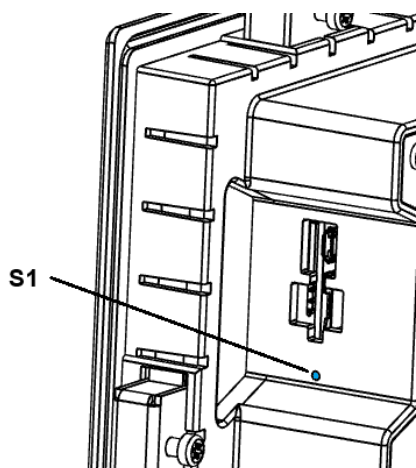

Fig. 33: Function button (S1)

Function button (S1)		
Operating status	Action	Command
Boot phase	Press and hold.	Boat in maintenance mode
CODESYS PLC/	Press briefly.	Switch between run and stop mode of the PLC
	Press and hold.	Stop the PLC with reset of the variables (cold reset)

The reset/stop button S1 is located on the left-hand side of the device.
 To prevent unintentional actuation, the stop/reset button can only be actuated with a pointed object (biros, screwdriver).
 The function depends on the current operating status of the controller.

CODESYS Stop - Start - Reset

A running CODESYS application is stopped by briefly pressing the button. The Run / Stop LED changes from green to red. Pressing the button again briefly starts the CODESYS application. The Run / Stop LED changes from red to green. If the button is held down for longer than 5 seconds, a "Reset warm" is triggered. After the time has elapsed, the Run / Stop LED flashes quickly and the button can be released. The control unit is now in reset mode.

Service Mode

To enter service mode, the controller must be switched off. Then press and hold the button and switch the controller on again. The button must be held down until the Run/Stop LED flashes yellow every 2 seconds

6.4. Troubleshooting

6.4.1. No network connection

- ▶ Check cabling/switch.
- ▶ Check whether an IP address has been assigned twice.
- ▶ Check the network settings on the PC: The subnet and subnet mask must match the settings in the control unit.
- ▶ Check the firewall/anti-virus programs on the PC.
- ▶ Check for unknown IP address (see 6.4.3).

6.4.2. With error stop

- ▶ Log in to device via web browser.
- ▶ Determine the cause of the error (Diagnostics > PLC Log/System Log).
- ▶ Eliminate the cause of the error.
- ▶ Restart the device (reset the device, see also 6.4.3).

Device is ready for use.

6.4.3. IP address unknown

If the IP address of the device is not known, the device shows it on the display when stopped. Alternatively, the device can also be reconfigured via a USB update.

1. Restart the device while holding down the S1 function button until the Run/Stop LED flashes yellow every 2 seconds.
The device is in maintenance mode and can be reached via the default IP address set at the factory.
2. Access the device via the standard IP address:
IP address: 169.254.255.XX
Netmask: 255.255.255.0
XX corresponds to the last 2 digits of the device serial number. Exception: 00 becomes 100.
3. Adjust and note the network settings.
4. Restart the device.
Maintenance mode is exited automatically.
The device is configured and ready for use.

6.5. Berghof Control System Manual

NOTE

Applicable documents!

- ▶ Further software descriptions and basic programming instructions can be found in the Berghof Control System Manual.
-

7. Maintenance / servicing

Repairs and maintenance may only be carried out by the manufacturer or its authorised customer service.

7.1. Maintenance

WARNING

Uncontrolled and unpredictable operational behavior!

Failures or malfunctions may result in uncontrolled and unpredictable operational behavior.

- ▶ Do not insert, connect, undo or touch any connections whilst the device is in operation.
- ▶ Before starting any work on the device, switch off all power feeds, including those to any connected peripherals (sensors and programmable devices etc. with independent power supplies).

If the device is used correctly, it should not require maintenance.

- ▶ Make sure all the ventilation holes are kept free of obstructions.
- ▶ Do not open the device. Contact the customer service if work is required on the device.

7.2. Cleaning

NOTE

Damage to the device

The front panel is of glass and must not be exposed to any mechanical or chemical stress.

- ▶ Do not use any high-pressure cleaners or steam jets.
 - ▶ Do not use any corrosive cleaning products, any thinners, any abrasive media or any hard objects.
 - ▶ Do not apply any undue force to the front face. Do not bend the device.
 - ▶ Do not place any heavy, hard or sharp-edged objects on the device.
 - ▶ Do not dismantle the devices.
-
- ▶ To prevent malfunctions due to unintentional operation, switch off the appliance to clean the front panel.
 - ▶ Only clean surfaces with a dry, lint-free cloth.
 - ▶ Only clean the display glass with normal window cleaning agents or alcohol-based solutions.

8. Uninstallation

1. Disconnect the device and its peripherals from the power supply.
2. Unplug all plug connectors and cables.

NOTE

Damage to the device!

If uninstallation is performed carelessly the device can fall out of the installation cut-out or be damaged.

- ▶ Do not tilt the device.
- ▶ Secure the device against falling, especially when taking it out of the installation cut-out.

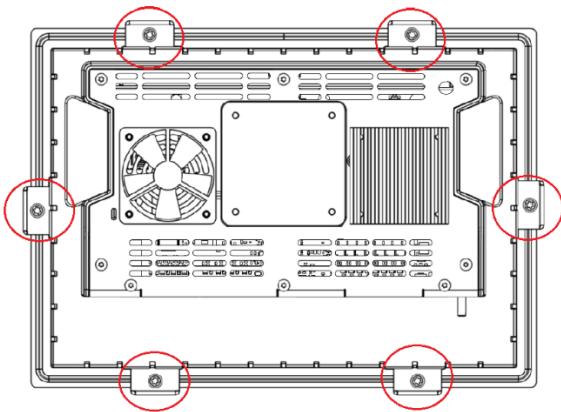

DC-Pi Prime 7 / 10

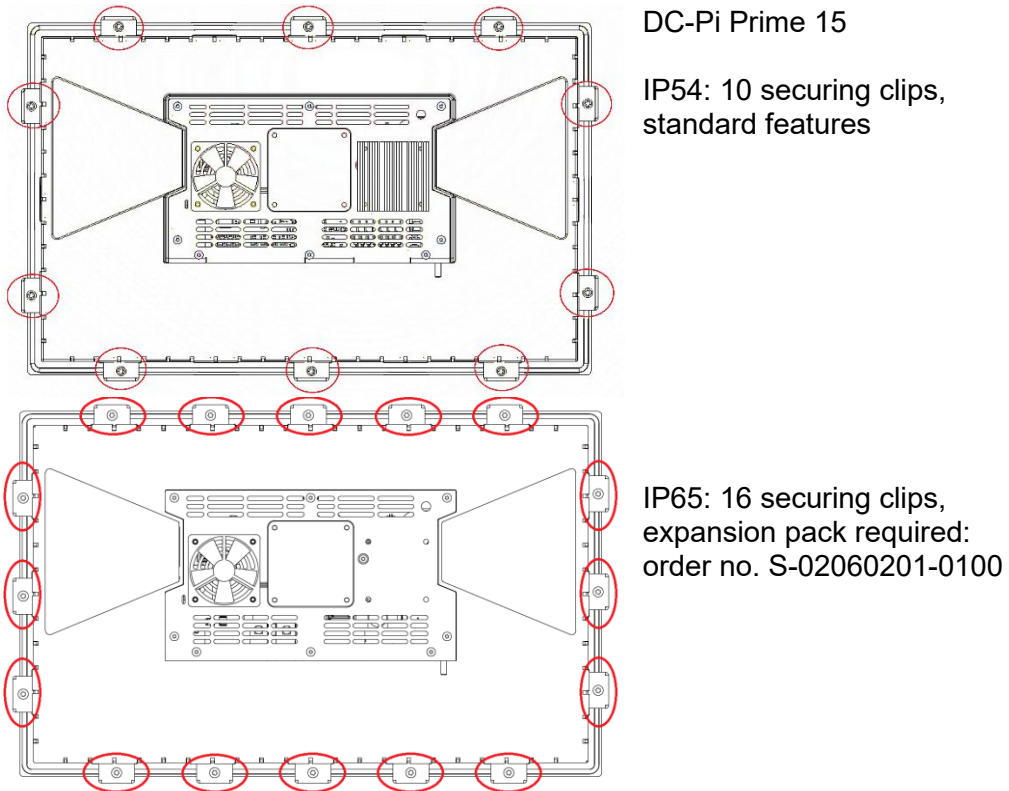

Fig. 34: Fully tightening the securing clips

3. Undo the screws on all the securing clips equally.
DC-Pi Prime 7" / 10": 6x securing clip
DC-Pi Prime 15": 10x securing clip for IP54 / 16x securing clip for IP65

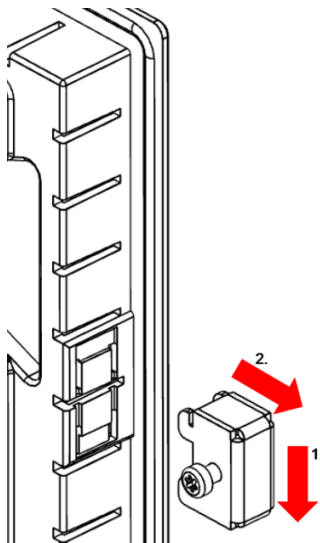

Fig. 35: Removing the securing clips

4. Remove the securing clips.

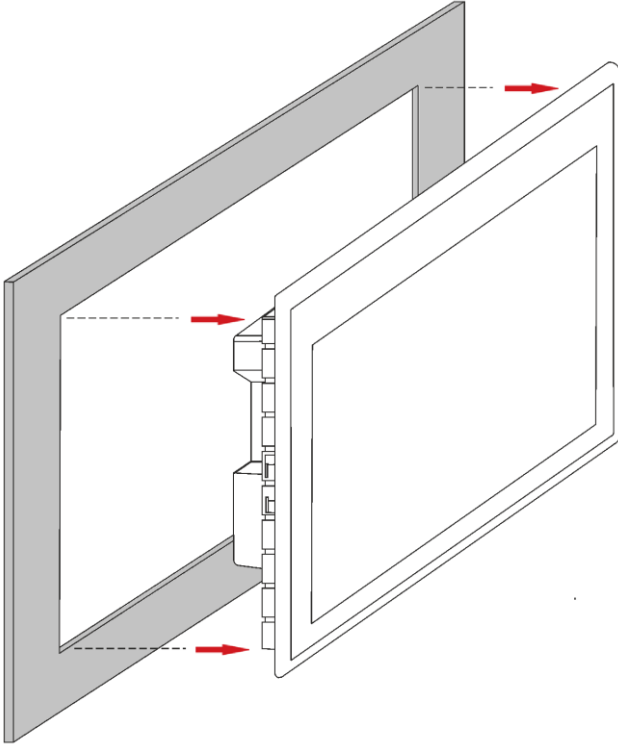

Fig. 36: Pushing the device out of the installation cut-out

5. Push the device evenly forwards out of the installation cut-out

9. Disposal

The device contains the following components which need to be disposed of separately:

- Metals
- Electronic components

The respective national regulations for disposal of electrical devices in B2B trade are applicable.

The following options are available for disposal of the device:

Disposal by the manufacturer

Unless agreed otherwise, devices can be sent back for disposal.

Disposal in accordance with regional regulations

- ▶ Dismantle the device and disassemble it completely into its component parts.
- ▶ Send the metal parts for metal recycling.
- ▶ Sort the electronic parts (circuit boards, drives etc.).
- ▶ Dispose of the electronic scrap in accordance with the national laws and regulations

10. Information and options

Dialogue Controller	DC-Pi Prime 15	DC-Pi Prime 10	DC-Pi Prime 7
Display	Full HD	WXGA	WVGA
Item no.	S-01010403-xx08	S-01010403-xx05	S-01010403-xx04
Display diagonal	15.6"	10.1"	7"
Resolution	1920 x 1080 Pixel	1280 x 800 Pixel	800 x 480 Pixel
Colours	TFT: 16.7 M (24 bit/pixel)		
Brightness	0 - 800 cd/m ³ adjustable		
CPU, user memory			
CPU	Raspberry Pi CM4 (1.5GHz Quad Core)		
Program memory (flash)	8GB to 32GB eMMC		
Data memory (RAM)	1GB to 8GB		
Retain memory (FRAM)	100 kB		
Sizes and weights			
Dimensions (WxHxD)	403.7 x 253.1 x 69.8 mm	262 x 186 x 69.3 mm	207.5 x 146.5 x 69.3 mm
Weight	2.28 Kg	1.12 Kg	0.86 Kg
Operating conditions			
Ambient temperature	If the installation instructions are observed, the following applies to the front and rear of the appliance		
Operation			
passively cooled	-10 °C to +55 °C	-10 °C to +55 °C	
with fan	-10 °C to +60 °C	-10 °C to +65 °C	
Relative humidity	max. 85 %, non-condensing		
Transport, storage			
Ambient temperature	-20 °C to +70 °C		
Relative humidity	max. 85 %, non-condensing		
Operation			
Assembly	Switch cabinet installation using a securing clip Optional VESA mount		
Certifications	CE, UKCA, optionally available: UL, in preparation: FCC		

Dialogue Controller	DC-Pi Prime 15	DC-Pi Prime 10	DC-Pi Prime 7
Visualisation	Target Visu (display), WEB Visu (WEB server, HTML5)		
Touch operation	Capacitive, multi-touch		
Vibration resistance			
Vibration	Sinusoidal (EN 60028-2-6) Test: Fc 10...150 Hz, 1G (operation mode)		
Shock	15 G (approx. 150 m/s ²), 10 ms duration, half-sine (EN 60068-2-27) Examination: Ea		
EMC, protection class			
EMC Emission	EN IEC 61000-6-3:2022-06, residential area		
EMC Immunity	EN IEC 61000-6-2:2019-11, industrial area		
Protection class	III		
Insulation resistance	SELV (Ue < 30V) according to EN 61131-2, 500 VDC test voltage		
Protection category	Rear IP20 (not evaluated by UL), Front IP54 (not evaluated by UL) with 10 securing clips, Front IP65 (not evaluated by UL) with 16 securing clips	Rear IP20 (not evaluated by UL), Front IP65 (not evaluated by UL) 6 securing clips	Rear IP20 (not evaluated by UL), Front IP65 (not evaluated by UL) 6 securing clips
UL Enclosure Type	Type 1		
Power supply (24 V power supply unit)			
Supply voltage	+24 V DC (-20 % / +25 %) SELV max. AC voltage component 5%		
Power consumption	max.1.2 A at +24 V DC	max.0.8 A at +24 V DC	max.0.8 A at +24 V DC
Current consumption dig. Outputs	Depending on the output load, max. 4 A (8 x 0.5 A)		
Polarity reversal protection	Integrated		
Ethernet interfaces			
Number / type of interface	2x 10/100/1000 Base T		
Connection technology	RJ45		

Dialogue Controller	DC-Pi Prime 15	DC-Pi Prime 10	DC-Pi Prime 7
Protocols	Standard: TCP/IP, NTP, FTP Option: Modbus, BACnet, PROFINET, EtherNet/IP, SNMP, KNX, OPC UA, IoT		
EtherCAT interface			
Number / type of interface	1x EtherCAT (EtherCAT master), can also be configured as Ethernet		
Connection technology	RJ45		
CAN bus interface			
Number / type of interface	1x CAN bus		
Connection technology	RJ45		
Protocols	Standard: CANOpen Master Option: J1939		
Serial interfaces			
Number / type of interface	1x RS-232 / 1x RS-485		
Connection technology	RJ45, RS-232 and RS-485 combined		
Protocols	Standard: Serial communication Option: Modbus RTU		
USB interfaces			
Number / type of interface	2x USB 3.2Gen. / Host USB connector Port A		
Max. Amperage	0.5A per port		
Number of mating cycles	max. 1000		
Further functions			
Real-time clock	Yes, (buffer time > 30 days), accuracy +/- 7ppm		
microSD card slot	1x microSD card slot (SDHC and SDXC) (S02 and higher)		
Expansion slots	2x M.2 (S02 and higher) (Optional memory expansion, interface expansion, AI hardware acceleration)		
Hardware	Optional: Watchdog for system monitoring		
Beeper	Optional extension		
Heat sink and fan	Optional extension		

Dialogue Controller	DC-Pi Prime 15	DC-Pi Prime 10	DC-Pi Prime 7
Inputs / Outputs			
Digital I/O	8x digital input (type 1 / 3; 1ms)		
	8x digital output (rated current: 0.5 A per output; 1ms)		
Analogue inputs	Up to 4x analogue-in measuring channels for current / voltage (0...+10V, 0...+20mA) Resolution: 12 bit, internal filtering configurable		
	Up to 4x high-precision analogue-in measurement channels for current / voltage (-10 V...+10 V, -20mA...+20mA, 4x PT100 / PT1000 2-wire or 2x PT100 / PT1000 3-wire) Resolution: 24 bit, internal filtering		
Analogue outputs	Up to 2x analogue-out voltage sources Resolution 12 bit (0...10V, loadable up to min. 1kOhm impedance)		

10.1. Device variants DC-Pi Prime 7 / 10 / 15

	Variants		
	S01	S02	S04
CAN	-	x	x
RS 232	-	x	x
RS 485	-	x	x
USB 2.0	x	-	-
USB 3.2 Gen 1	-	x	x
8x digital input	-	-	x
8x digital output	-	-	x
4x analog input (12 bit) 4x analog input (24 bit)	-	-	x
2x analog output	-	-	x
MicroSD-Card-Slot	-	x	x
Beeper	-	-	x
Order option fan	x	x	x
Order option SSD	-	x	x
Order option AI Accelerator	-	x	x

10.2. Type plate

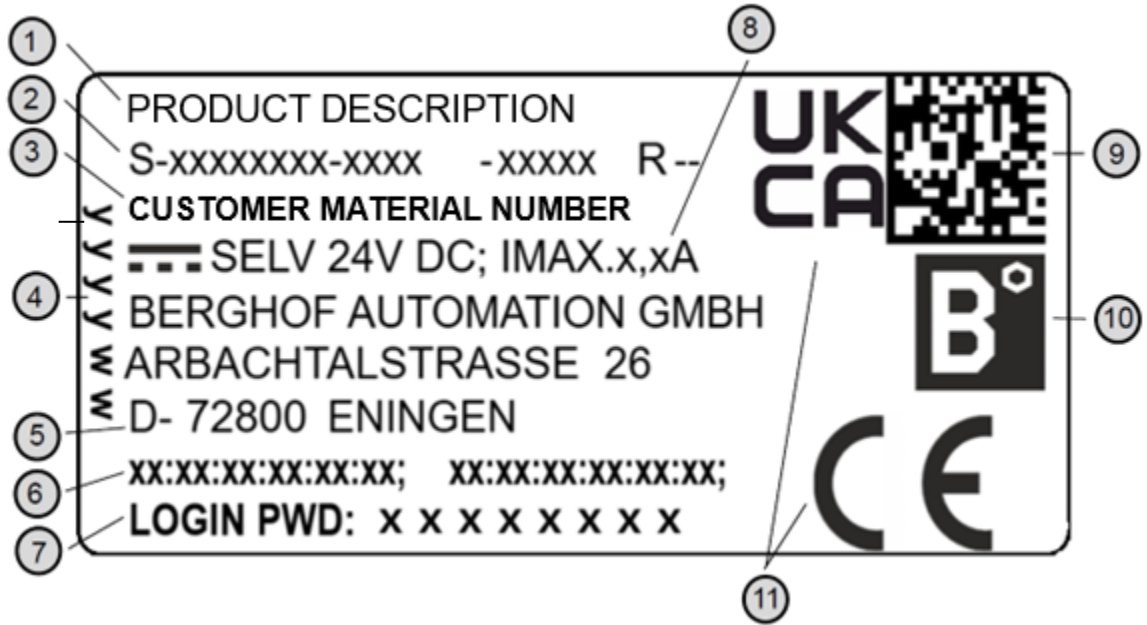

Fig. 37: Type plate

Pos.	Designation	Pos.	Designation
1	Product description	7	Default password
2	Order no./serial no. / version identification	8	Supply voltage and maximum current
3	Customer material number	9	QR code (identification no.)
4	Production date (year/week)	10	Manufacturer's logo
5	Manufacturer (manufacturer's address)	11	Conformity marking
6	MAC addresses of the unit		

10.3. Device variants and identification

Designation	Order number
DC-Pi Prime7 S01	S-01010403-0104
DC-Pi Prime 7 S02	S-01010403-0204
DC-Pi Prime 7 S04	S-01010403-0404
DC-Pi Prime 10 S01	S-01010403-0105
DC-Pi Prime 10 S02	S-01010403-0205
DC-Pi Prime 10 S04	S-01010403-0405
DC-Pi Prime 15 S01	S-01010403-0108
DC-Pi Prime 15 S02	S-01010403-0208
DC-Pi Prime 15 S04	S-01010403-0408

10.4. Options and extensions

The options are ordered via the compilation
 "Order number Option1 Option2 ..."

e.g.: **S-01010403-0205 S001 S002 H001**

In addition to the order number, additional extensions in the form of hardware, software and customer-specific options are labelled as follows:

Option code	Option type
S000-S999	Software options e.g. field buses
H000-H999	Hardware options e.g. connector set, certifications
C000-C999	Customised options e.g. customised firmware, customised front foil

For more information on the options available for this device, please refer to the product catalog or the homepage.

The additional features included or installed in the respective device are listed in the option label. This label can be found on the device and/or on the packaging.



Fig. 38: Option label

11. Standards and certificates

11.1. Standards

EU directives applied

- EMC Directive 2014/30/EU
- RoHS Directive 2011/65/EU (also 2015/863/EU)

EU standards applied

- Technical documentation for the assessment of electrical and electronic products with respect to the restriction of hazardous substances
EN IEC 63000:2019-05
- Programmable controllers - Part 2: Equipment requirements and tests
EN 61131-2:2007
- Electromagnetic compatibility (EMC) - Part 6-3: Generic standards - Emission standard for equipment in residential environments (IEC 61000-6-3:2020)
EN IEC 61000-6-3:2022-06
- Electromagnetic compatibility (EMC) - Part 6-2: Generic standards - Immunity standard for industrial environments (IEC 61000-6-2:2016)
EN IEC 61000-6-2:2019-11

UKCA guidelines applied

- EMC Directive from 2016
UK S.I. 2016 No. 1091
- RoHS Directive 2012
UK S.I. 2012 No. 3032

UKCA standards applied

- Technical documentation for the assessment of electrical and electronic products with respect to the restriction of hazardous substances
BS EN IEC 63000:2018
- Programmable controllers - Equipment requirements and tests
BS EN 61131-2:2007
- Electromagnetic compatibility (EMC). Generic standards. Emission standard for equipment in residential environments
BS EN IEC 61000-6-3:2021-03
- Electromagnetic compatibility (EMC). Generic standards. Immunity standard for industrial environments
BS EN IEC 61000-6-2:2019-02

11.2. Declaration of conformity

The declarations of conformity, technical data and further information can be found on our website at <https://www.berghof-automation.com/downloads/>

Select the relevant area (automation technology) and complete the form. Information on data protection can also be found on the page.

12. Customer service / Addresses

Repairs and maintenance may only be carried out by the manufacturer or its authorised customer service.

12.1. Customer service

Berghof Automation GmbH
Arbachtalstrasse 26
72800 Eningen
Germany
T +49.7121.894-183
e-mail: support-controls@berghof.com
www.berghof-automation.com

12.2. Repair service

Please send the goods to the Berghof Repair Service for repair, quoting the RMA number and giving a detailed description of the fault.

Berghof Automation GmbH
BU Automation Technology
Repair service
Arbachtalstrasse 26
72800 Eningen

You can request the RMA number at:
www.berghof-reparaturservice.com

12.3. Addresses

CAN in Automation; international manufacturer and user organization for CAN users in automation:

CAN in Automation e.V. (CiA)

Am Weichselgarten 26

91058 Erlangen

headquarters@can-cia.de

www.can-cia.de

EtherCAT Technology Group

ETG Headquarters

Ostendstraße 196

90482 Nuremberg

info@ethercat.org

www.ethercat.org

DIN Media Verlag GmbH, 10787 Berlin

or

VDE-Verlag GmbH, 10625 Berlin

or

Research via the Internet: www.iec.ch

13. Appendix

13.1. Notes on copyright and license of the software

The firmware of the devices contains free software. Parts of this software are available under the following and other OpenSource licenses:

- GNU General Public License (GPL)
- GNU Lesser General Public License (LGPL)
- Mozilla Public License (MPL)
- FreeType License (FTL)

The source code of the free software can be requested from Berghof customer service at cost price within three years of delivery of the device.

13.2. List of illustrations

Fig. 1: Overview of B-Primis DC-Pi Prime 10 S01 (rear)	15
Fig. 2 : Overview of B-Primis DC-Pi Prime 10 S02-S04 (rear).....	15
Fig. 3: Dimensions DC-Pi Prime 7	19
Fig. 4: DC-Pi Prime 7 mounting cut-out	20
Fig. 5: Dimensions DC-Pi Prime 10	21
Fig. 6: DC-Pi Prime 10 mounting cut-out	22
Fig. 7: Dimensions DC-Pi Prime 15	23
Fig. 8: DC-Pi Prime 15 mounting cut-out	24
Fig. 9: Inserting into the mounting cut-out.....	25
Fig. 10: Mounting the securing clips.....	26
Fig. 11: Fully tightening the securing clips	27
Fig. 12: Power supply X1	29
Fig. 13 : Block diagram DC-Pi Prime	30
Fig. 14: Digital inputs and outputs X10	32
Fig. 15: Principle circuit diagram output, positive switching.....	34
Fig. 16: Principle circuit diagram input, positive switching.....	35
Fig. 17: Operating ranges of the digital inputs (type 1/3).....	35
Fig. 18: Analogue inputs (U/I) / Analogue outputs (U) X11.....	37
Fig. 19 : Analogue inputs (U/I/PT) X12	37
Fig. 20: Connection example: Voltage output AO (U).....	46
Fig. 21: Connection example: Voltage input AIN_U.....	47
Fig. 22: Connection example: Current input AIN_I	47
Fig. 23: Connection example: Temperature measurement	48
Fig. 24: Ethernet interface X3 and X4	49
Fig. 25: USB interfaces X5 and X6	50
Fig. 26: CAN interface X 8	51
Fig. 27: RS-232 / RS-485 interface X7.....	52
Fig. 28: RS-485 switchable terminating resistor	53
Fig. 29: Login window.....	55
Fig. 30: List of settings in the web interface	56
Fig. 31: "Network Configuration" page	57
Fig. 32: Positions of the operating status LED s	58

Fig. 33: Function button (S1)	60
Fig. 34: Fully tightening the securing clips	66
Fig. 35: Removing the securing clips.....	66
Fig. 36: Pushing the device out of the installation cut-out.....	67
Fig. 37: Type plate	74
Fig. 38: Option label	76