

B-PRIMIS DC-Pi PRIME OPEN series

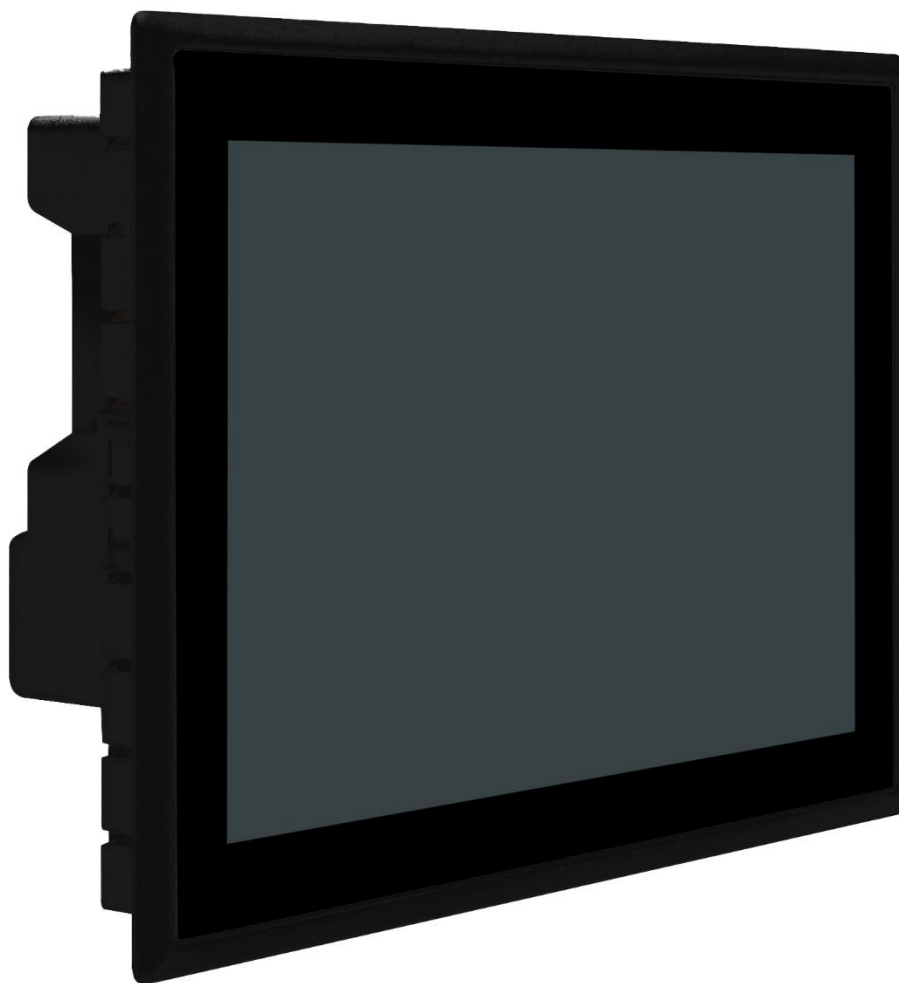

Copyright © Berghof Automation GmbH

This document may not be passed on or reproduced, and its contents may not be used or communicated without our express consent. All rights reserved.
Infringements will result in compensation for damages.

Disclaimer

The content of this publication has been checked for compliance with the hardware and software described. However, deviations cannot be ruled out, so we cannot guarantee complete conformity. The information in this publication is checked regularly, and any necessary corrections are included in subsequent editions. Suggestions for improvement are always welcome. We reserve the right to make technical changes.

Trademark

- EtherCAT® is a registered trademark and a patented technology, licensed by Beckhoff Automation GmbH, Germany.
- CiA® and CANopen® are registered community trademarks of CAN in Automation e. V.
- ARM® and Cortex® are registered trademarks of ARM Limited.
- Raspberry Pi is a registered trademark of the Raspberry Pi Foundation

The rights to all companies and company names as well as goods and product names mentioned here are held by the respective companies.

Notes on this manual

This manual:

- This manual contains the product-specific information valid at the time of publication.
- should be read carefully before commissioning the device in order to avoid errors during operation and to familiarize yourself with the device.
- It is only complete together with the product-related hardware and software user manuals required for the respective application.
- does not include repair instructions. If repairs are required, please contact your supplier or Berghof Automation GmbH directly

You can reach us at:

Berghof Automation GmbH

Arbachtalstrasse 26

72800 Eningen

Germany

T +49.7121.894-0

E-mail: controls@berghof.com

www.berghof-automation.com

Berghof Automation GmbH is certified according to DIN EN ISO 9001.

Change log

Version	Date	Description
1.0	11.06.2025	First version
1.1	29.07.2025	Correction of the dimensions at DC-Pi Prime Open 15 mounting cut-out
1.2	23.02.2026	Description of device variants S01, S02, S04 Extension of sections microSD card (SDHC and SDXC) EMC IP protection class Formal correction of Ethernet assignments Addition of MicroSD card for device variants Overview: Device characteristics S01 NEW
1.3	23.03.2026	Correction of the numbers of securing clips with 15'' Adjustment certification DIN EN ISO 9001 Information regarding UL certification added
1.4	12.06.2026	Correction Power consumption DC-Pi Prime 15 Information regarding UL certification and Protection category added

Table of contents

1.	GENERAL INFORMATION	7
1.1.	Notes on the manual	7
1.2.	Symbols and visual depictions	8
1.3.	Hazard categories and signal terms	8
1.4.	Qualified personnel	9
1.5.	Duty of care	9
1.5.1.	General	9
1.6.	Intended use	10
1.7.	Transportation and storage	11
	Transport and storage	11
	Operation	11
1.8.	Unpacking	11
2.	SECURITY	12
2.1.	Safety-oriented systems	12
2.2.	Safety instructions	12
	Working on the device	13
2.3.	Cyber Security	13
3.	PRODUCT DESCRIPTION	14
3.1.	Overview	15
3.2.	Scope of delivery and accessories	16
	Scope of delivery	16
	Accessories	16
3.3.	Product features	17
	Features at a glance	17
	Assembly	17
	Processor	17
	Ethernet	17
	USB	17
	CAN interface	17
	Serial interface	17
	Optional extension: Digital and analog inputs/outputs	17
	Real-time clock	17
	µSD card	18
4.	INSTALLATION	19
4.1.	Preparation for front installation DC-Pi Prime Open 7	19
4.2.	Mounting preparation for front installation DC-Pi Prime Open 10	21
4.3.	Mounting preparation for front installation DC-Pi Prime Open 15	23
4.4.	Installation	25

5.	CONNECTION	28
5.1.	Power supply	28
	Installation	28
5.1.1.	Connecting the power supply	29
5.2.	Data connections	30
5.2.1.	Block diagram.....	30
5.2.2.	Digital inputs and outputs	31
5.2.3.	DC Pi Prime Open connector overview from version S02	31
5.2.4.	Analog inputs and outputs	36
	Basics for connecting the analog inputs	36
	Data of the analog inputs (both resolutions)	38
	Operating modes of the analog inputs with 12-bit resolution	39
	Data of the analog outputs	44
5.2.5.	Connection examples.....	46
	Voltage output AO (U) on X11.....	46
	Voltage input AIN (U) on X11	47
	Temperature measurement AI (PT).....	48
	2-wire measurement.....	48
	3-wire measurement.....	48
5.2.6.	Ethernet.....	49
5.2.7.	USB.....	50
5.2.8.	CAN bus.....	51
5.2.9.	Serial interfaces.....	52
	Signal interference and terminating resistor	53
	Connections with GND	53
6.	OPERATION	54
6.1.	Switching on and off	54
	Switch on.....	54
	Switch off.....	54
6.2.	Initial commissioning network	55
6.2.1.	Standard commissioning	55
6.2.2.	Commissioning via SSH terminal	55
6.3.	Operation	56
6.3.1.	Status displays	56
6.3.2.	Real-time clock with voltage buffer	56
6.3.3.	µSD card	56
6.3.4.	Push-button S1.....	57
6.3.5.	Interfaces	57
	Analog and digital inputs and outputs.....	58
6.4.	Troubleshooting	59
6.4.1.	No network connection	59
7.	MAINTENANCE / SERVICING	60
7.1.	Maintenance	60
7.2.	Cleaning	60
8.	UNINSTALLATION	61

9.	WASTE DISPOSAL	64
10.	INFORMATION AND OPTIONS	65
10.1.	Device variants DC-Pi Prime Open 7 / 10 / 15	68
10.2.	Type plate	69
10.3.	Device variants and identification	70
10.4.	Options and extensions.....	71
11.	STANDARDS AND CERTIFICATES	72
11.1.	Standards.....	72
	EU directives applied.....	72
	EU standards applied	72
	UKCA guidelines applied.....	72
	UKCA standards applied	72
11.2.	Declaration of conformity.....	73
12.	CUSTOMER SERVICE / ADDRESSES	74
12.1.	Customer service	74
12.2.	Repair service.....	74
12.3.	Addresses	75
13.	APPENDIX.....	76
13.1.	Notes on copyright and license of the software.....	76
13.2.	List of illustrations	76

1. General information

Please read this user manual carefully before commissioning. Failure to do so may result in damage to the appliance and injury to operating personnel.

Safety-relevant information and their classifications are explained in the section Hazard categories and Signal terms (1.3). These instructions must always be observed!

1.1. Notes on the manual

This user manual is part of the product and applies to the following devices:

- B-Primis DC-Pi Prime Open 7 S01 , S02 ; S04
- B-Primis DC-Pi Prime Open 10 S01 ; S02 ; S04
- B-Primis DC-Pi Prime Open 15 S01 , S02 ; S04

1.2. Symbols and visual depictions

The following symbols and illustrations are used in this user manual:

Icon	Meaning
→ ...	List entry
▶ ...	Single action instruction or list of action instructions that can be executed in any order.
1. ... 2. ...	List of instructions that must be carried out in the specified order.
	Further information on the product

Structure of the warnings:

1.3. Hazard categories and signal terms

The signaling terms described below are used for warnings that you must observe for your personal safety and to prevent damage to property.

The signal terms have the following meaning:

DANGER

Serious injury or death

Non-compliance with the safety features will result in death or serious injury.

- ▶ Observe actions for prevention.

WARNING

Possible serious injury or death

Non-compliance with the safety features may result in death or serious injury.

- ▶ Observe actions for prevention.

CAUTION

Possible minor injuries

Non-compliance with the safety features may result in minor injuries.

- ▶ Observe actions for prevention.

NOTE

Possible material damage

Non-compliance with the safety features may result in damage to property.

- ▶ Observe actions for prevention.

1.4. Qualified personnel

Installation, start-up and maintenance of the device require qualified personnel.

Qualified personnel in the sense of this documentation and the safety instructions contained therein are trained specialists who are familiar with the safety concepts of automation technology and who are authorized to assemble, install, start-up, ground and label devices, systems and circuits in accordance with the standards of safety technology.

1.5. Duty of care

1.5.1. General

The operator or further processor (OEM) must ensure the following:

- The device is only used as intended.
- The appliance may only be operated if it is in perfect working order.
- The user manual is always available in legible condition and complete.
- Only suitably qualified and authorized specialists may assemble, install, commission and maintain the appliance.
- These specialists are regularly instructed in all applicable issues of occupational safety and environmental protection and are familiar with the contents of the user manual, in particular the safety instructions contained therein.
- The device markings and identifications as well as safety and warning notices attached to the device are not removed and are always kept in a legible condition.
- The national and international regulations for the control of machines and systems applicable at the respective place of use of the device are complied with.
- Users always have all the latest information on the device and its use and operation that is relevant to their needs.
- The user is responsible for coordinating the use of the safety-related control components with the responsible authorities and complies with their specifications.

1.6. Intended use

The device is part of a modular automation system for industrial control applications in the medium to upper performance range.

The automation system is designed for use within overvoltage category I (IEC 60364-4-44) for the control and regulation of machines and industrial processes in low-voltage systems with the following general conditions:

- Maximum rated supply voltage, 1000 V AC voltage (50/60 Hz) or 1500 V DC voltage
- Environment with maximum pollution degree 2 (EN 61010-1)
- Altitude up to 2000 m N. N.
- Only indoors without direct UV radiation
- Max. Ambient temperature according to the technical specifications see "technical data", p. 65

The faultless and safe operation of the automation system requires qualified project planning, proper transport, storage, installation and use as well as careful maintenance.

The automation system may only be used within the scope of the data and applications specified in this documentation and the associated user manuals.

The automation system must only be used:

- as intended
 - in a technically perfect condition
 - without any unauthorised modifications
 - by qualified users
-
- ▶ Observe the regulations of the trade associations, the Technical Inspection Association, the VDE regulations or corresponding national regulations.
 - ▶ The device is intended for installation in a suitable mounting cut-out on industrial machines and systems indoors.
 - ▶ When installing make sure that the existing sealing profiles are undamaged.
 - ▶ Observe the ambient conditions applicable to operation see "technical data", p. 65



The device is optionally available with UL certification.

This complies with UL Enclosure Type 1. Suitable installation must be ensured.

1.7. Transportation and storage

The device is sensitive to shocks, strong vibrations, moisture and extreme temperatures.

Transport and storage

- ▶ Protect the device from heavy mechanical stress during transport.
- ▶ Always transport the device in its original packaging.
- ▶ Observe the ambient conditions applicable for storage, see "technical data", p. 65
- ▶ Ensure that the device is protected from exposure to moisture and humidity.

Operation

- ▶ Do not operate the device after storage or transport until it has reached the permissible operating conditions.
- ▶ Wait at least 12 hours after condensation before operating the device.

1.8. Unpacking

On receipt of the device, it must be ensured that the packaging is undamaged and complete.

- ▶ Check the packaging for external damage.
- ▶ In the event of serious damage to the packaging or if damage to the contents is recognizable: Do not open the packaging any further and inform the carrier and your supplier immediately.
- ▶ Remove the packaging and keep the packaging for re-transport.
- ▶ Check the contents for recognizable transport damage.
- ▶ Check the contents against the order for completeness and be sure to keep all documentation supplied. The documentation supplied contains important information about the device and is an integral part of the product.
- ▶ If you notice transport damage or discrepancies between the order and the delivered contents: Inform the supplier immediately.

2. Security

2.1. Safety-oriented systems

The use of the device Terminals in safety-related systems requires specific measures. Wherever a Ethernet Terminal is to be used in a safety-related system, the user must be given comprehensive advice by the manufacturer in addition to information on any available standards or regulations regarding safety installations.

- ▶ Before starting any work on devices, switch off all power feeds, including to peripherals.
- ▶ Keep all ventilation holes unobstructed.

Failure in certain components in an electronic control system may result in uncontrolled and/or unpredictable operational behavior.

- ▶ All types of failure must be considered at the system level and the associated preventative measures identified.
- ▶ If necessary, request information from your automation system provider.

2.2. Safety instructions

CAUTION

Possible minor injuries and burns to the skin surface.

Failure to observe the safety measures may result in minor injuries / burns to the skin surface!

The device may be operated only when it is in good working order. Exposed sharp edges pose an injury risk.

- ▶ If you discover damage to the front glass of the device, do not continue to operate the device. Immediately disconnect it from the power supply.

The housing of the device can heat up considerably, especially at elevated ambient temperatures, due to the passive cooling of the internal components. The surface temperature may exceed the burn threshold depending on the duration of contact.

- ▶ If possible, avoid touching the rear panel of the device during operation.
 - ▶ If you plan to perform any work on the device, such as installing or removing it in the control cabinet or connecting or disconnecting a cable, switch off the device and allow it to cool down for a while.
 - ▶ It is recommended to wear personal protective equipment such as gloves when handling the heated device.
-

Working on the device

Do not start work on the device until all necessary safety precautions have been taken. Take precautions to avoid unforeseeable functional events and movements of the system.

- ▶ Bring the system into a safe condition.
- ▶ Switch the system and the device off.
- ▶ Secure the system against being switched on again.
- ▶ Disconnect the device from the system.

The casing of the device must not be opened.

- ▶ If work on the internal parts of the device is necessary, contact the manufacturer see "Addresses".

2.3. Cyber Security

- ▶ Never place the control unit on the Internet without additional protection mechanisms, this product is not designed for this purpose
- ▶ Change the default passwords specified on delivery
- ▶ Always use an upstream external firewall to prevent access from the outside to the inside.
- ▶ Use the security mechanisms of VPN server portals (e.g. IXON) to which the controller can actively connect via VPN or comparable mechanisms
- ▶ Always use https instead of http
- ▶ Deactivate unnecessary services such as FTP/SSH/Webserver

Contact person for Cyber Security of Berghof products:

Berghof Product Security Incident Response Team

psirt.automation@berghof.com

3. Product description

The device is a control module with a display. For the control and regulation of automatic and industrial processes in low-voltage system.

The connection level of the devices for all external connections is located on the underside. These devices are intended for installation in a prepared mounting cut-out in a flat surface. All connections are pluggable.

3.1. Overview

Device characteristics S01

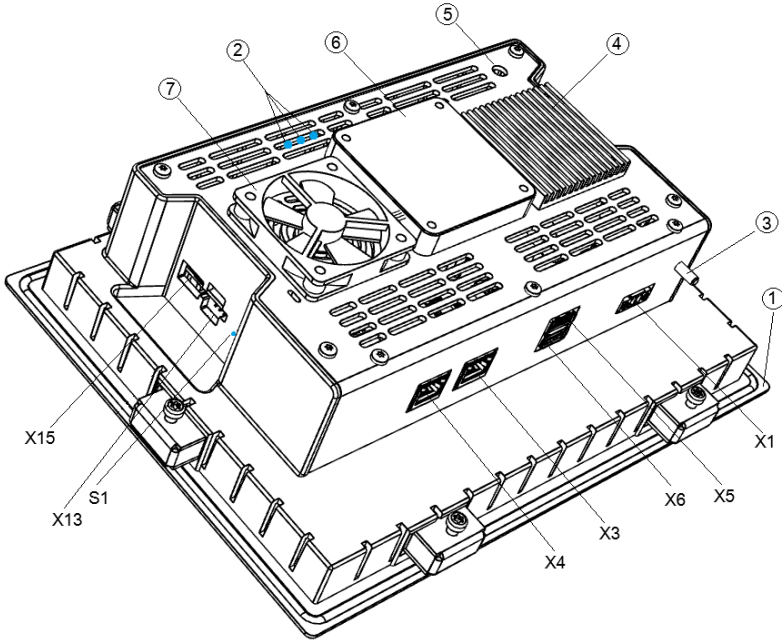

Fig. 1: Overview of B-Primis DC-Pi Prime Open 10 S01 (back)

Device characteristics S02-S04

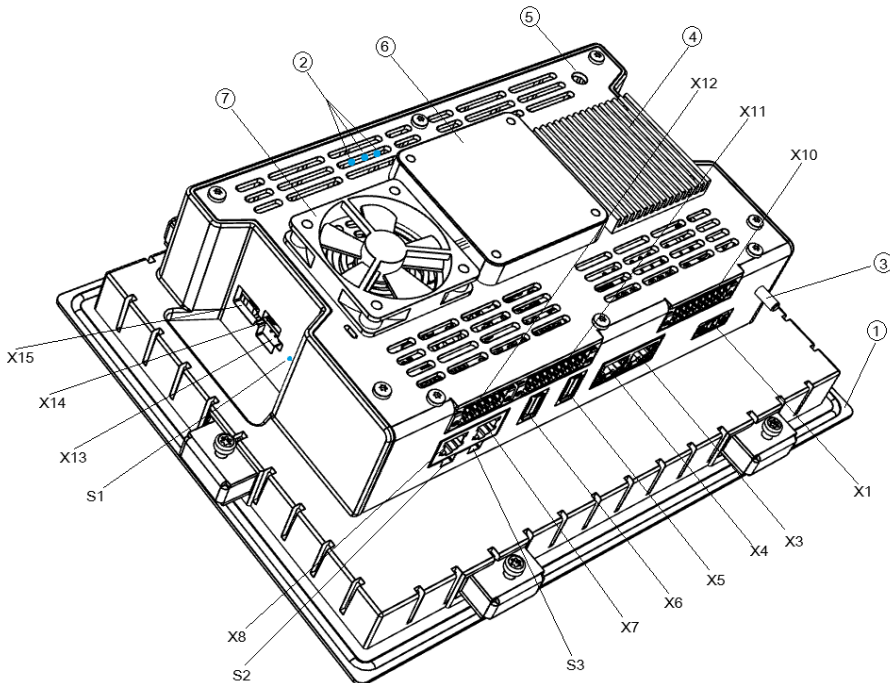

Fig. 2 : Overview of B-Primis DC-Pi Prime Open 10 S02-S04 (back)

Pos.	Designation	Pos.	Designation
1	Display 10.1 inch		
2	LEDs: Power, Run/Stop, Error	X7	RS-232 [COM1] / RS-485 [COM2] combined
3	Earthing connection	X8	CAN bus [CAN0]
4	Cooling (optional)	X10	Digital inputs / outputs (optional) with own supply connection
5	WLAN antenna connection (optional)	X11	Analog inputs & outputs (optional)
6	Vesa mount (optional)	X12	High-precision analog inputs (optional)
7	Fan (optional)	X13	Debug interface (do not use - only for Berghof service personnel)
X1	Power supply	X14	MicroSD cards connection (SDHC and SDXC) (S02 and higher)
X3	Ethernet [ETH0]	X15	USB Device
X4	Ethernet [ETH1]	S1	Function button (reset and run/stop)
X5	USB host	S2	Terminating resistor CAN
X6	USB host	S3	Terminating resistor RS485

3.2. Scope of delivery and accessories

Scope of delivery

- B-Primis DC-Pi Prime Open
- 2-pin power supply plug
- I/O plug 12-pin from version S04
- I/O plug 18-pin from version S04
- Securing clips:
 - DC-Pi Prime Open 7"/10": 6 pieces
 - DC-Pi Prime Open 15: 10 pieces

Accessories

The following accessories can be ordered directly or via the options (see chapter 10.4):

- Securing clip, order no. S-02060201-0100
- DC-Pi Prime S04 plug set, order no. S-02020107-0100
- Power supply plug DC-Pi Prime order no. S-02020203-100

3.3. Product features

Features at a glance

- Raspberry Pi CM4 (1.5 GHz Quad Core)
- Program and data memory (RAM): 1 GB to 8 GB RAM
- Program memory (Flash): 8 GB to 32 GB eMMC Flash
- Retain memory 100 kB
- 2 Ethernet 1000/100/10 Base-T interfaces
- 2 USB host interfaces
- 1 CAN interface
- 2 serial interfaces (1x RS-232; 1x RS-485)
- 1 μ SD card slot from S02 onwards (suitable for SDHC and SDXC)
- Optionally expandable: Digital & analog I/O
- Real-time clock

Assembly

The device is designed for installation in a front panel or in a control cabinet in an industrial environment.

Processor

The device has a Raspberry Pi Compute Module 4 in the basic configuration (1.5 GHz Broadcom BCM2711, Quad Core Cortex-A72 (ARM v8) 64-bit SoC) Depending on the selected variant with different storage expansion.

Ethernet

Two Ethernet interfaces with 10/100/1000 Mbit/s are available. The TCP/IP and UDP/IP protocols enable a very flexible connection to visualization software, to higher-level control units or to the IT infrastructure.

USB

The USB 3.2 Gen 1 (S02-S04) / USB 2.0 (S01) host interface is a widely used peripheral interface. This enables simple data exchange or expansion with compatible USB devices.



USB sticks with FAT/FAT32/exFAT/ext3/ext4 formatting are supported.

For support of other USB devices, please contact our technical support.

CAN interface

The device has a standard CAN interface that can be used up to 1 Mbit/s.

Serial interface

The device has 2 serial interfaces (1x RS-485; 1x RS-232), which are provided in combination on the same RJ45 socket.

Optional extension: Digital and analog inputs/outputs

The device can optionally be ordered with digital inputs/outputs and analog inputs/outputs with different resolutions and accuracies.

Real-time clock

A maintenance-free real-time clock buffered with a capacitor can be set to the current time via a software interface. The buffer time is 30 days.

μSD card

The DC-Pi-Prime has 1 x μSD card slot, e.g. for data dumps.

This slot is suitable for all SDHC and SDXC μSD cards and available from variant S02 onwards.

4. Installation

4.1. Preparation for front installation DC-Pi Prime Open 7

The device is intended for installation from the front into a rectangular cut-out on a panel. The support material must be rigid and be from 1 to 3 mm thick.

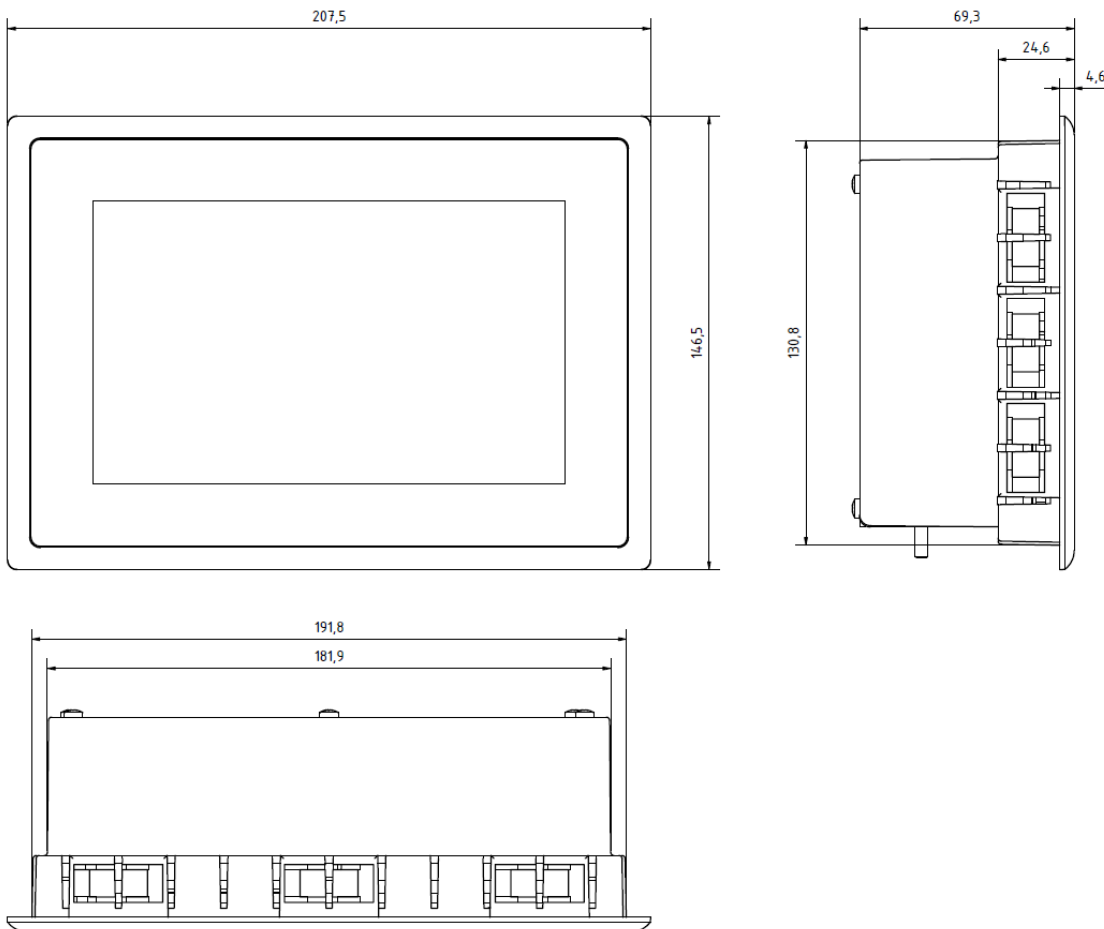

Fig. 3 : Dimensions DC-Pi Prime Open 7

Requirements:

- To allow sufficient air circulation, it must be ensured that the device has a clear space of at least 20 mm all round at the rear.
- The carrier material for the mounting cut-out is sufficiently thick, flat and stable.

NOTE

Damage to the device!

Installation on uneven support material can lead to mechanical stresses and cracks in the front face or malfunctioning of the touch screen.

- ▶ Make sure that the mounting points of the device are all in a common plane, with no more than maximum ± 0.5 mm variation.

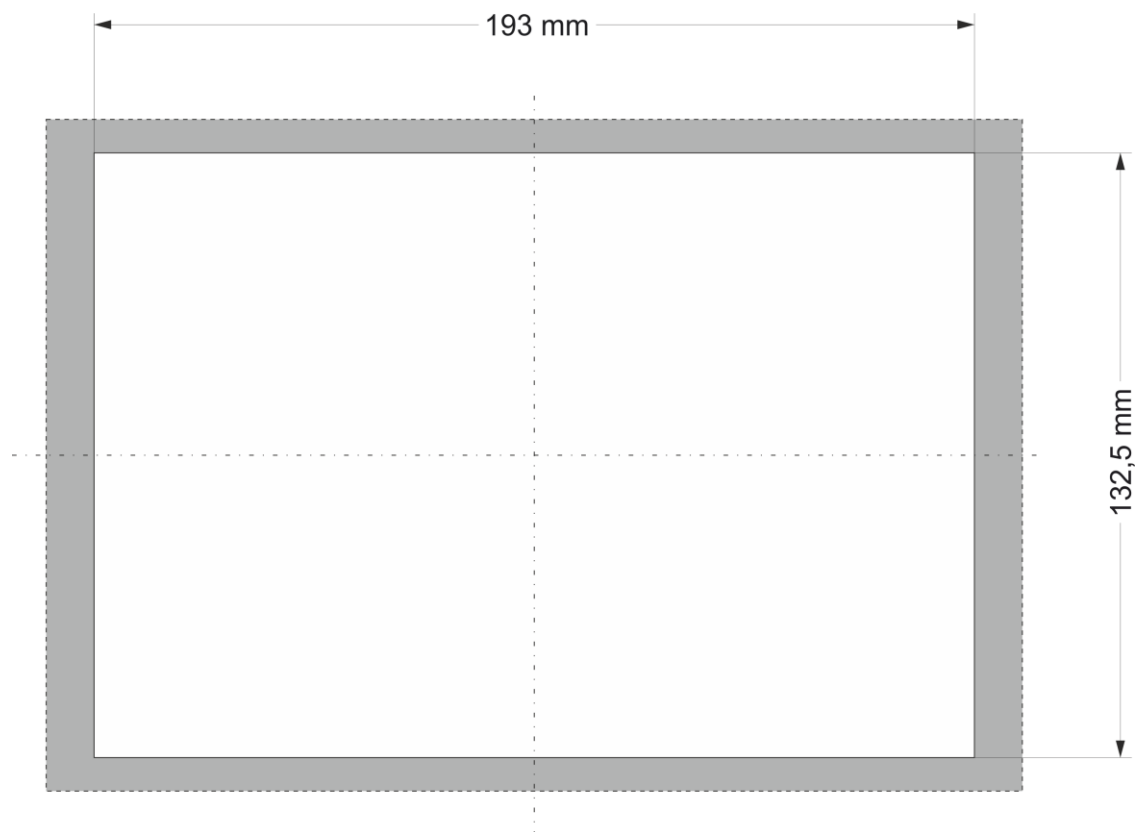

Fig. 4: DC-Pi Prime Open 7 mounting cut-out

- ▶ Cut a rectangular mounting cut-out from the backing material:
 Height: 132.5 mm
 Width: 193 mm
 Max. Corner radius: 1.5 mm



Optimum thickness of the backing material: 1.0 to 3.0 mm

4.2. Mounting preparation for front installation DC-Pi Prime Open 10

The device is intended for installation from the front into a rectangular cut-out on a panel. The support material must be rigid and be from 1 to 3 mm thick.

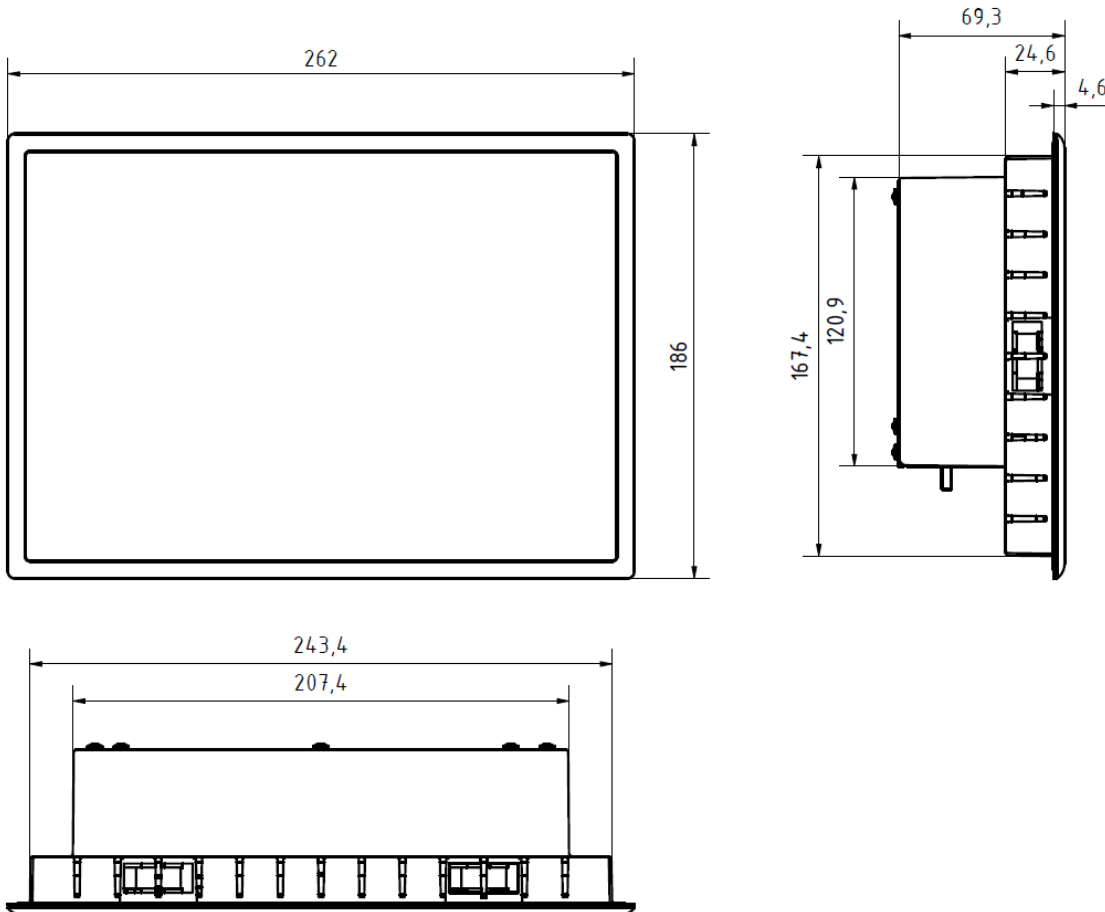

Fig. 5 : Dimensions DC-Pi Prime Open 10

Requirements:

- The appliance has at least 20 mm free space all around the rear of the installation location to ensure sufficient air circulation.
- The carrier material for the mounting cut-out is sufficiently thick, flat and stable.

NOTE**Damage to the device!**

Installation on uneven support material can lead to mechanical stresses and cracks in the front face or malfunctioning of the touch screen.

- ▶ Make sure that the mounting points of the device are all in a common plane, with no more than maximum ± 0.5 mm variation.

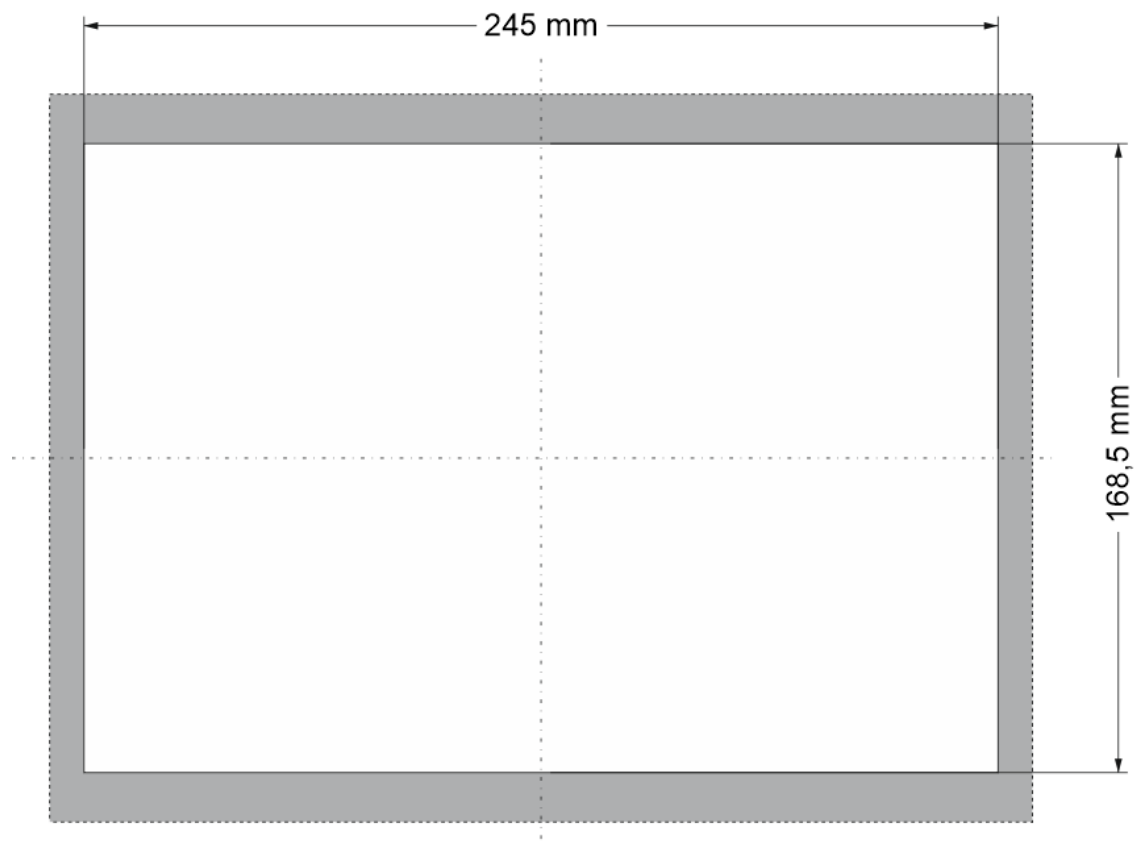

Fig. 6: DC-Pi Prime Open 10 mounting cut-out

- ▶ Cut a rectangular mounting cut-out from the backing material:
Height: 168.5 mm
Width: 245 mm
Max. Corner radius: 1.5 mm



Optimum thickness of the backing material: 1.0 to 3.0 mm

4.3. Mounting preparation for front installation DC-Pi Prime Open 15

The device is intended for installation from the front into a rectangular cut-out on a panel. The support material must be rigid and be from 1 to 3 mm thick.

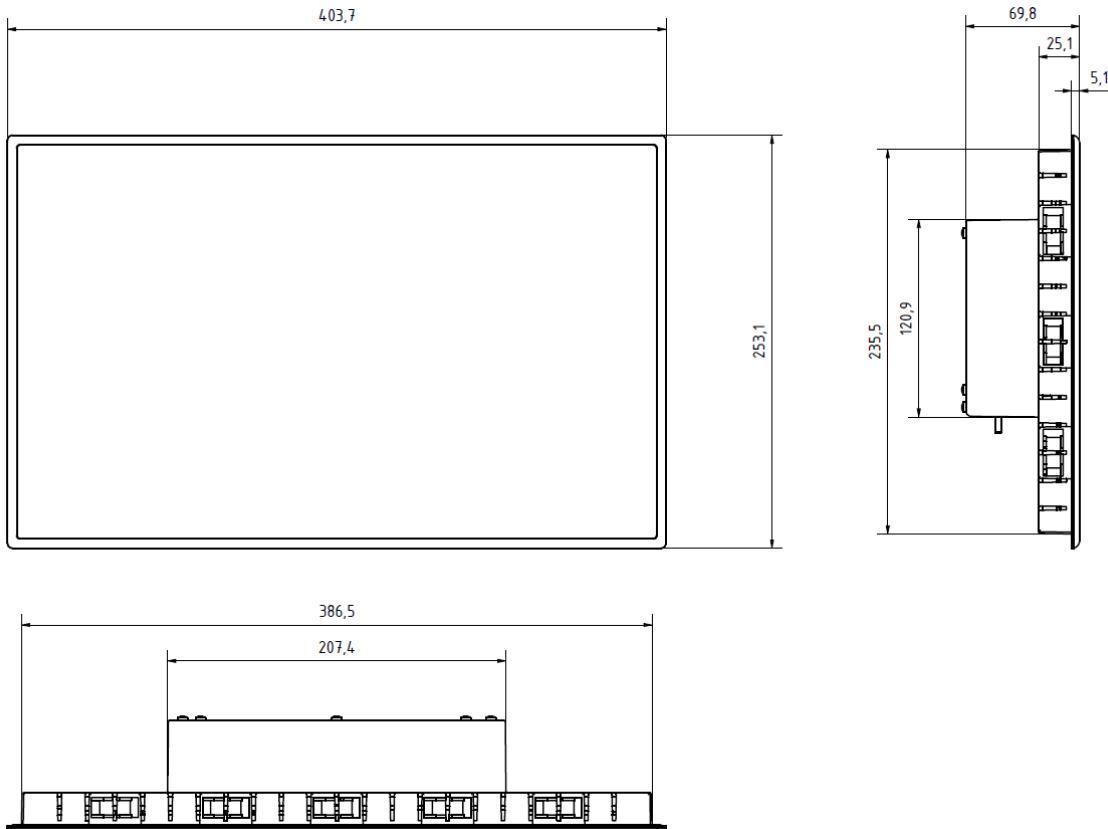

Fig. 7 : Dimensions DC-Pi Prime Open 15

Requirements:

- The appliance has at least 20 mm free space all around the rear of the installation location to ensure sufficient air circulation.
- The carrier material for the mounting cut-out is sufficiently thick, flat and stable.

NOTE

Damage to the device!

Installation on uneven support material can lead to mechanical stresses and cracks in the front face or malfunctioning of the touch screen.

- ▶ Make sure that the mounting points of the device are all in a common plane, with no more than maximum ± 0.5 mm variation.

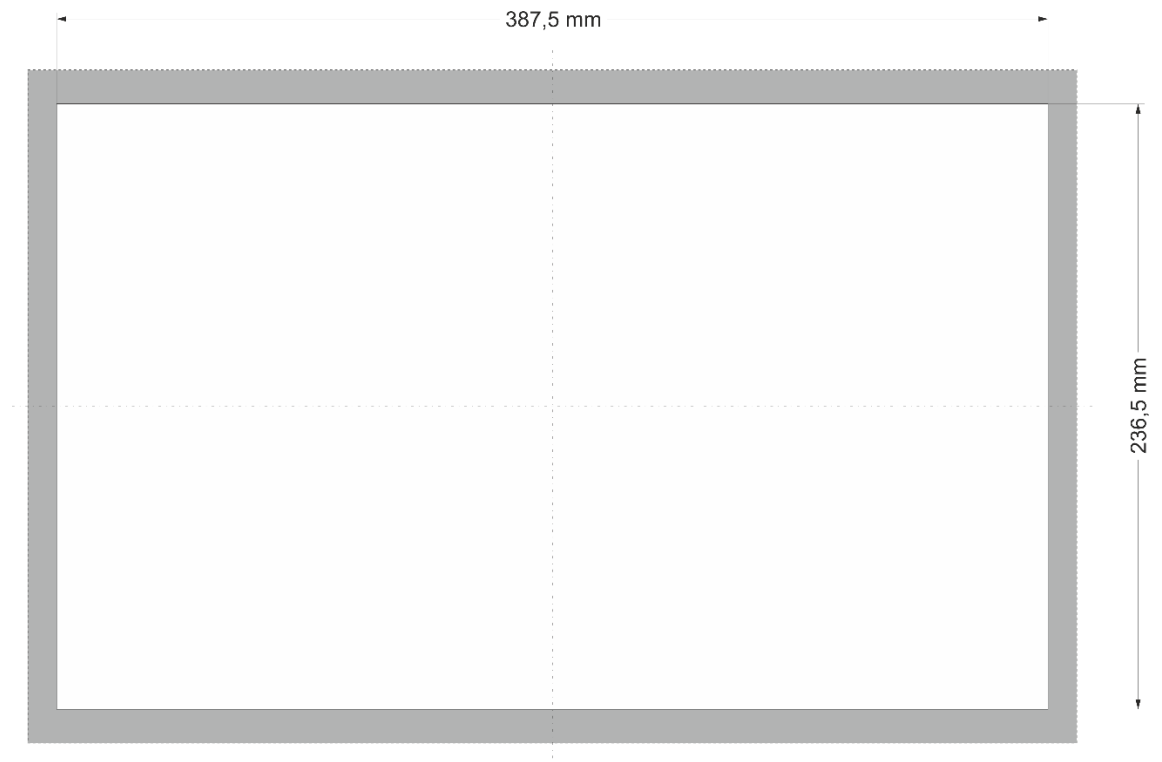

Fig. 8: DC-Pi Prime Open 15 mounting cut-out

- ▶ Cut a rectangular mounting cut-out from the backing material:
Height: 236,5 mm
Width: 387,5 mm
Max. corner radius: 1.5 mm

i Optimum thickness of the backing material: 1.0 to 3.0 mm

4.4. Installation

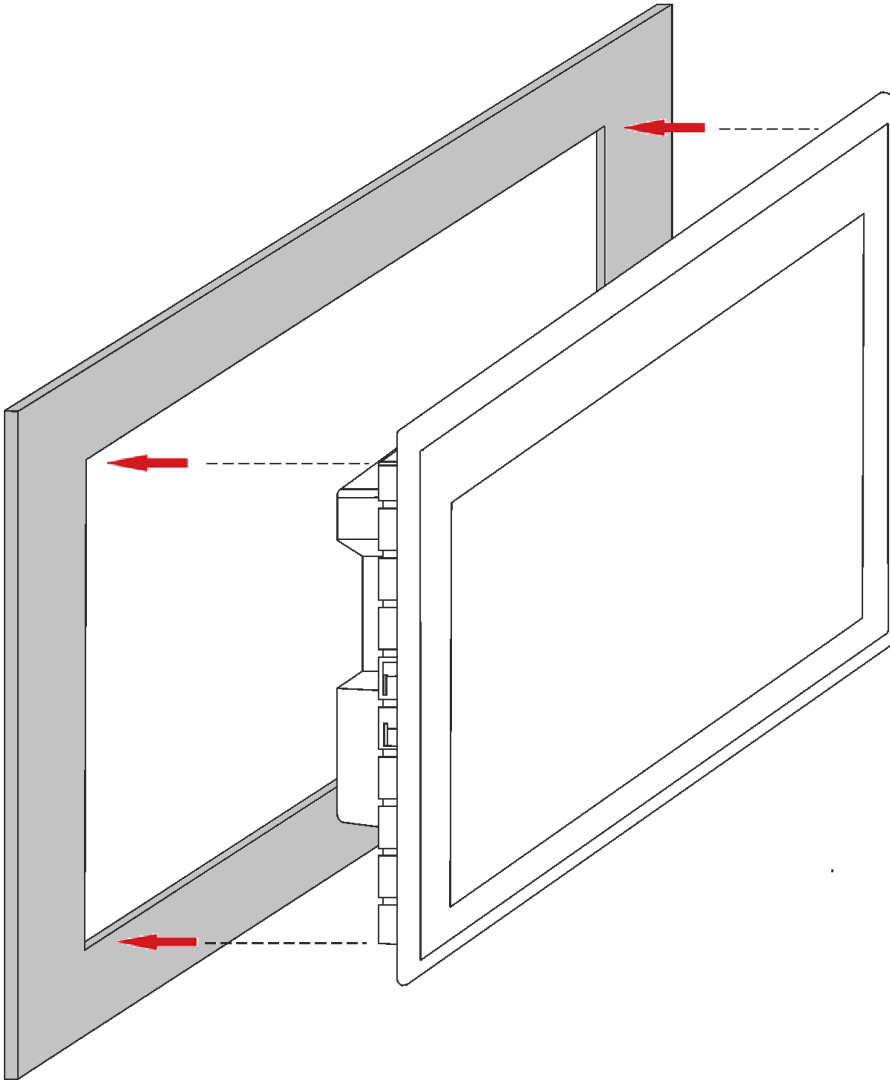

Fig. 9: Inserting into the mounting cut-out

Requirements:

- The securing clips must not be attached to the device.
- 1. Making sure the alignment is correct, push the device evenly into the installation cut-out.

NOTE

Damage to the device!

If installation is performed carelessly the device can fall out of the installation cut-out or be damaged.

- ▶ Do not tilt the device.
- ▶ Restrain the device against falling until the securing clips have been tightened.

2. Ensure that the device fits well all the way around.

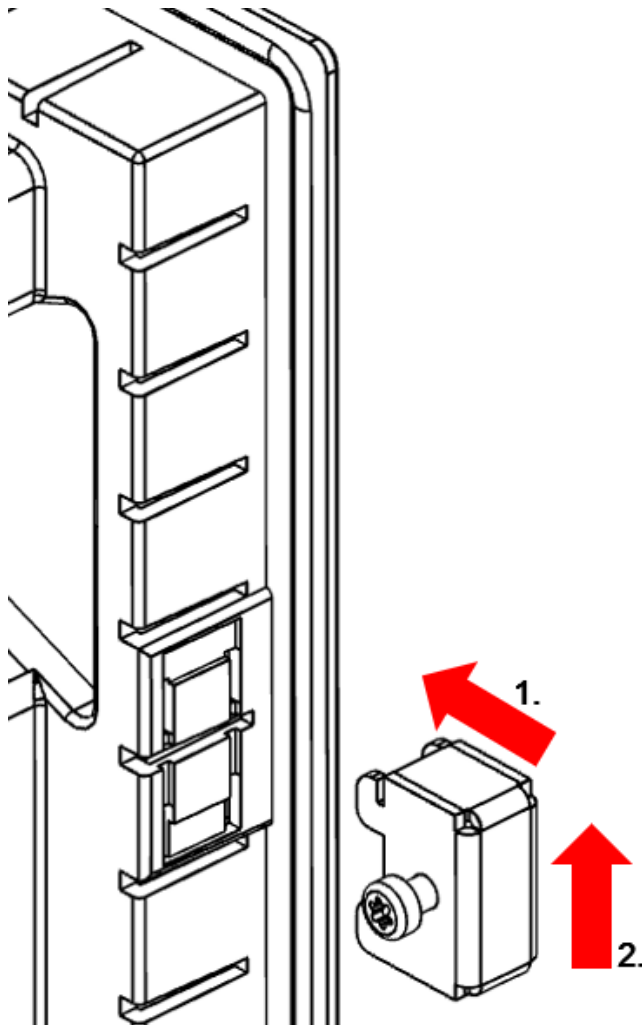
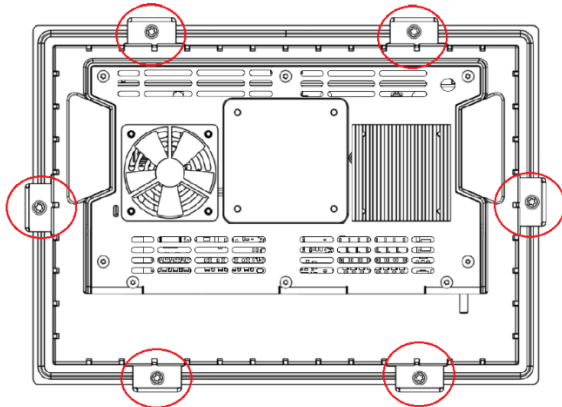
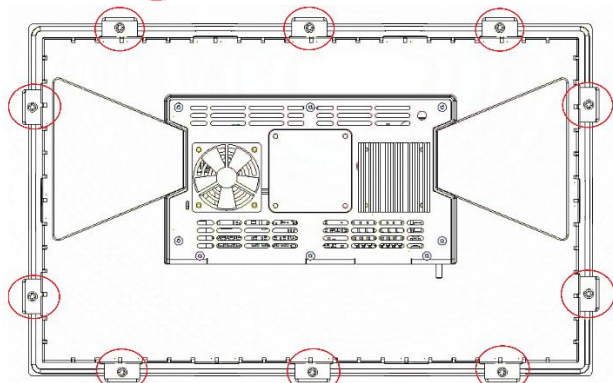

Fig. 10: Fitting the securing clip

3. Secure the device with 2 securing clips: Insert the securing clips into the cover at diagonally opposite points and tighten the screws finger-tight.



DC-Pi Prime Open 7 / 10



DC-Pi Prime Open 15

IP54: 10 securing clips,
standard features

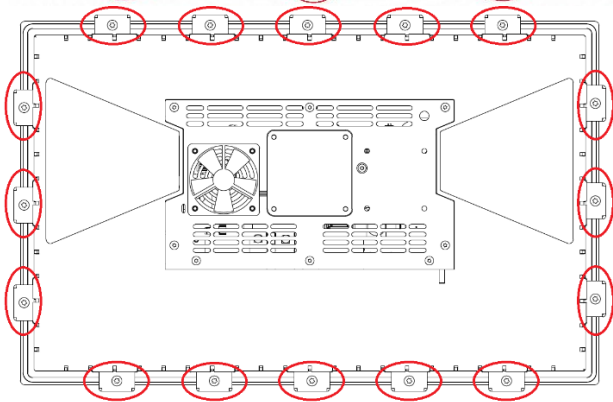

IP65: 16 securing clips,
expansion pack required:
order no. S-02060201-0100

Fig. 11: Tighten the securing clip

- Attach the remaining securing clips and tighten the screws of all securing clips evenly (max. 0.4 Nm).

DC-Pi Prime Open 7" / 10": 6x securing clip

DC-Pi Prime Open 15": 10x securing clip for IP54 / 16x securing clip for IP65

5. Connection

WARNING

Uncontrolled and unpredictable operational behaviour!

Failure of certain components in electronic control systems may result in uncontrolled and unpredictable operational behaviour.

- ▶ All types of failure and the associated protection systems must be taken into account at system level.
- ▶ Comply with all automation system manufacturer instructions.

5.1. Power supply

The device is powered by an external 24 V DC power supply.

- ▶ Before plugging in the device, ensure that the external power supply meets the required specifications (type K to 61131-2).

External power supply (24 V DC)

Supply voltage	+24 V DC SELV (-20 % / +25 %)
Ripple current proportion	Max. 5 % The DC voltage level must not fall below 20.4 V.
Power consumption	DC-Pi Prime 7: Total max.0.8 A at +24 V DC (PLC internal) DC-Pi Prime 10: Total max. 0.8 A at +24 V DC (PLC internal) DC-Pi Prime 15: Total max. 1.2 A at +24 V DC (PLC internal) With optional digital & analog extension additionally up to 4.2A at +24V DC (separate supply connection)

Installation

- ▶ Make all connections and cables in such a way that no interference from inductive and capacitive interference on the device.
- ▶ Ensure that the current and voltage resistance of the supply lines is sufficient.

5.1.1. Connecting the power supply

⚠ CAUTION

Live parts!

- ▶ Before starting any work on the device, switch off all power feeds, including peripherals.

DC-Pi Prime Open

- ▶ Connect the power supply to plug X1 according to the following table.

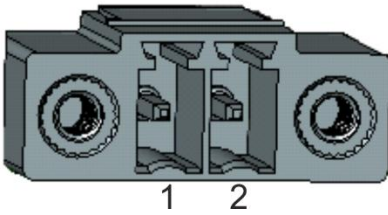

Fig. 12: Power supply X1

Power supply connector X1		
Pin	Ref.	Occupancy
1	L0+ 24 V	Supply 24 V DC (-20 %/+25 %)
2	L0-	GND 0 V DC

The following mating parts have been tested for the 15EDGRM-THR-3.5-02P-13-10Z (DEGSON) The following mating parts have been tested for the 15EDGRM-THR-3.5-02P-13-10Z (DEGSON) series connector and may be used with the device:

- **15EDGKNM-3.5-02P-13-1000Z (DEGSON)**

5.2. Data connections

5.2.1. Block diagram

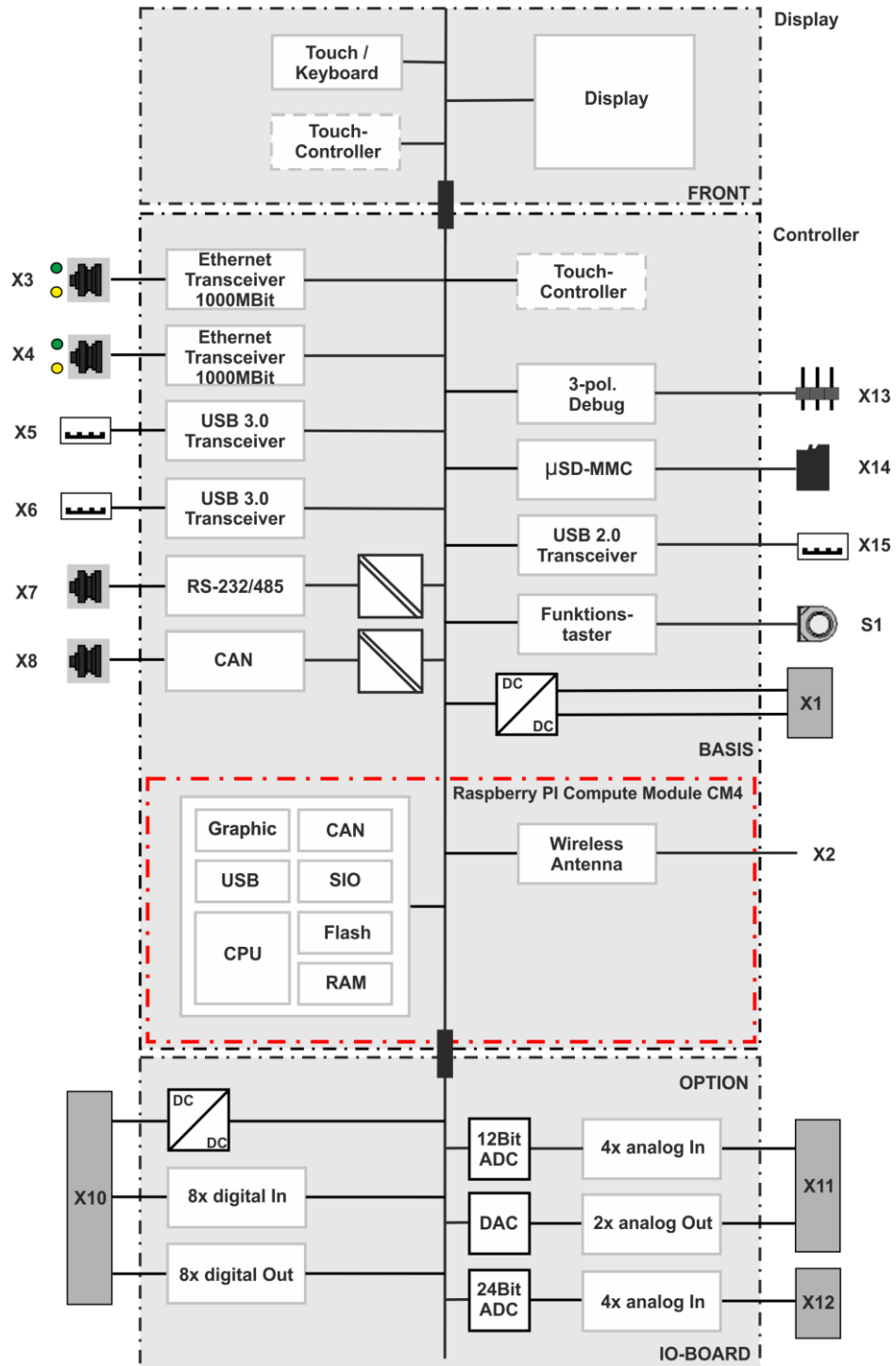

Fig. 13 : Block diagram DC-Pi Prime Open

5.2.2. Digital inputs and outputs

The digital outputs are positive-switching 24V outputs with an output current of max. 500 mA (per channel). They have a common reference potential (GND) to the supply voltage.

NOTE

Damage to the inputs or the device!

Voltages above ± 32 V can damage the inputs or the device.

- ▶ Do not apply a voltage exceeding ± 32 V to the inputs.

The digital inputs are positive switching inputs of type 1 or 3 (IEC 61131-2). They are designed for input voltages of nominally 24 V. The input signals are transmitted internally cyclically for process data processing. An open input is interpreted as static 0 (LOW). The inputs also have a common reference potential (GND).

The following mating parts have been tested for the plug connector 15EDGRHCM-THR-3.5-18P-13-1000Z (DEGSON) and may be used with the device:

- 15EDGKNHM-3.5-18P-13-00Z (DEGSON)

5.2.3. DC Pi Prime Open connector overview from version S02

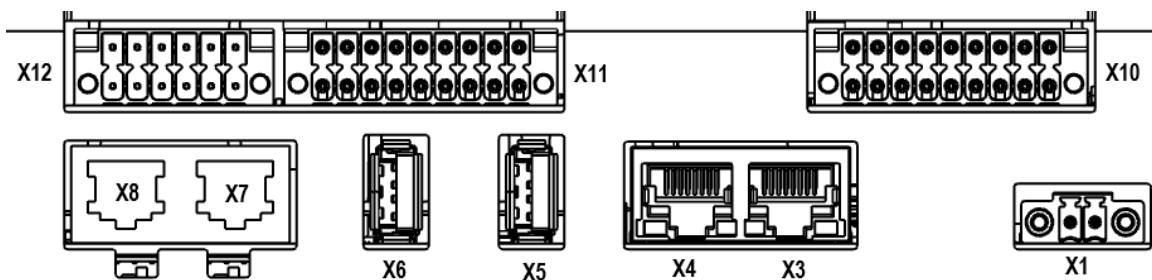

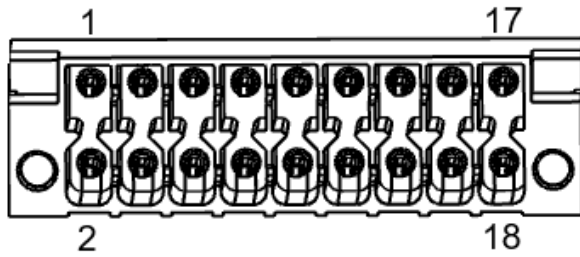

Fig. 14: Digital inputs and outputs X10

Digital inputs and outputs connector X10		
Pin	Ref.	Occupancy
1	DO 8	Digital output
2	DI 8	Digital input
3	DO 7	Digital output
4	DI 7	Digital input
5	DO 6	Digital output
6	DI 6	Digital input
7	DO 5	Digital output
8	DI 5	Digital input
9	DO 4	Digital output
10	DI 4	Digital input
11	DO 3	Digital output
12	DI 3	Digital input
13	DO 2	Digital output
14	DI 2	Digital input
15	DO 1	Digital output
16	DI 1	Digital input
17	+24V DC	Power supply (see "Power supply")
18	GND	Ground reference of the power supply

Data of the digital outputs		
Feature	Value	Description
Type of outputs	Semiconductors	Not storing, supplying current (plus switching)
Protective circuit for inductive loads	40 V clamping voltage (typ.) against +24 V	Fast excitation must be provided externally for large inductive loads
Status display	Yes	One yellow LED per output lights up at logic 1 (load side)
Overload protection	Yes	In case of thermal overload, self-resetting
Short-circuit protection Response threshold	Yes	Electronic current limitation: typ. 4 A The current is electronically limited. Response of the short-circuit protection from at least 1.1 A leads to thermal overload and triggering of the thermal overload protection. Permissible limit values based on cold state: max. 10,000 short circuits, total duration max. 500 hours.
Status for unsafe operating states	Logical 0	If the supply voltage is insufficient and when the control system is started up or shut down, the outputs are set to logic 0.
Output delay Level change	typ. 200 µs	-
Signal delay on activation	typ. 1 ms	Cyclical, depending on the cycle time set in the programming system
Output capacity	< 20 nF	-
Rated voltage	+24 V DC	-
Voltage drop (at rated current)	< 0,5 V	-
Rated current with logic "1" signal	0,5 A	Rated current per channel
Total current of all outputs	max. 4 A	In the event of an overload, the digital outputs switch themselves off (overtemperature protection)
Parallel connection of two outputs	max. 1 A	Maximum permissible value for a logic operation to increase the power

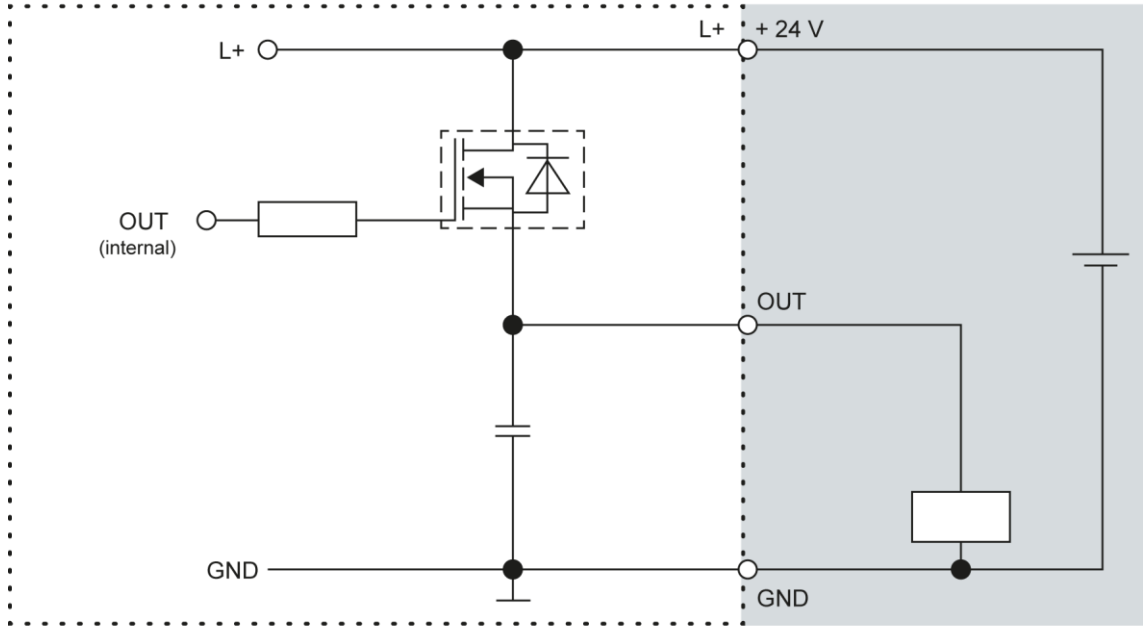

Fig. 15: Principle circuit diagram output, positive switching

Data of the digital inputs		
Feature	Value	Description
Type of inputs	Type 1 / 3	According to IEC 61131-2 Drawing current (positive switching)
Cable length	max. 30 m	For unshielded connection cables For cable lengths over 30 m, the cables must be shielded.
Cable cross-section in the switch cabinet	0.14-1.5 mm ² (26-16 AWG)	Align to connectors with limits according to UL specifications.
Field wiring	according to regulations and standards	Comply with all applicable local regulations and the requirements of DIN EN 61131-2.
Nominal load voltage	+24 V DC	-
Delay time	2.5µs	Applies to the transition from logical "0" to "1" and from logical "1" to "0"
Signal delay during evaluation	typ. 1 ms	Cyclical, depending on the cycle time set in the programming system
Polarity reversal protection	Yes	-
Potential separation	No	-
Status display	Yes	One yellow LED per input lights up for logic 1

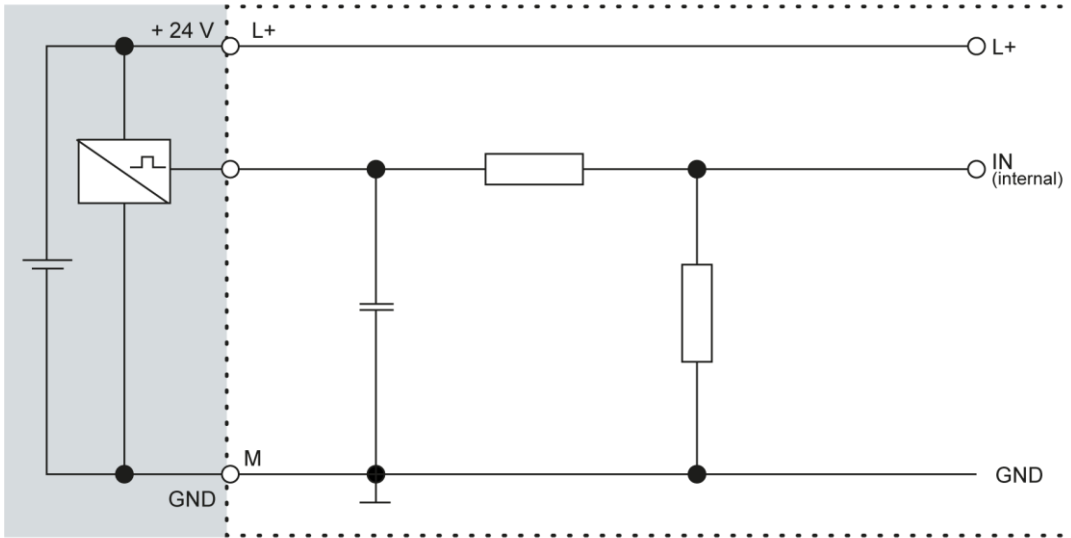

Fig. 16: Principle circuit diagram input, positive switching

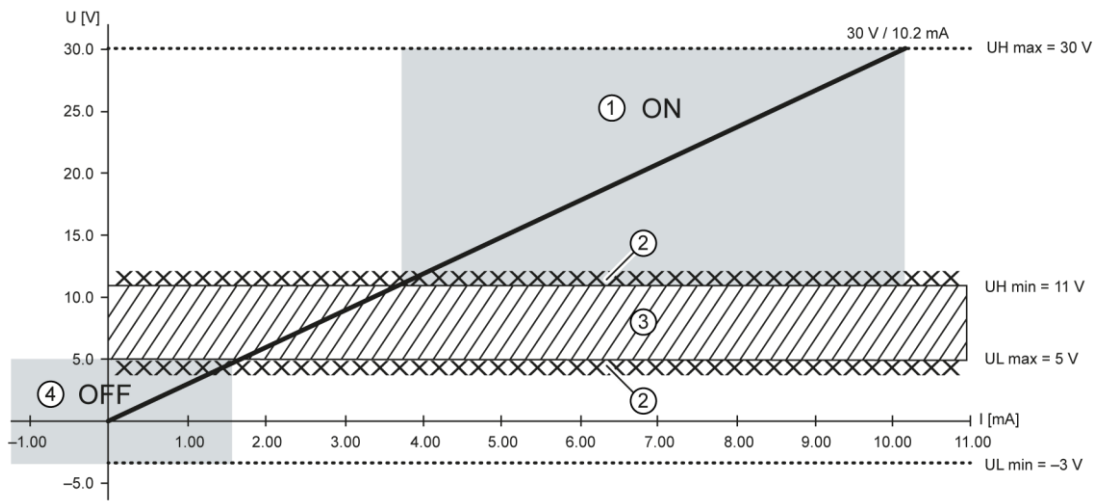

Fig. 17: Operating ranges of the digital inputs (type 1/3)

Pos.	Designation	Pos.	Designation
1	"ON" area	3	Transition area
2	Signal-to-noise ratio < 1 V	4	"OFF" area

5.2.4. Analog inputs and outputs

Basics for connecting the analog inputs

- An analog input channel always consists of two connections: input (AIN_U, AIN_I or AIN_UT) and AGND.
- The AIN_UT channels can either measure voltages or analyze PT100(0) sensors.
- Two associated AIN_UT channels can be used to compensate the lead resistances for PT100(0) measurements (3-wire measurement).
- The AIN_I and AIN_IT channels can only measure currents.
- The earth/ground/GND line of the current/voltage transmitter or temperature sensor connected to an analog input may only be connected to AGND (not to GND or PE (earth)).
- AGND must not be connected to the general GND of the control cabinet or to "M" of the control unit (GND and AGND are already connected within the control unit and specially filtered).
- AGND must not be connected directly to the protective earth conductor (PE) of the machine or system.
- Long cables and cables with a small cross-section lead to deviations in voltage inputs and PT100(0) measurements (cable resistance). These unavoidable deviations must be taken into account when planning the wiring.
- To avoid interference, analog I/O cables must be routed separately from digital signals and power-carrying conductors.
- Shielded cables are recommended for all analog I/O's. The shield is connected to the sensor or encoder and in the switch cabinet or near the control unit.

The following counterparts have been tested for the plug connector 15EDGRHCM-THR-3.5-18P-13-1000Z (DEGSON) or 15EDGRHCM-THR-M3.5-12P-13-1000Z (DEGSON) and may be used with the device:

- **15EDGKNHM-3.5-18P-13-00Z(H) (DEGSON)**
- **15EDGKNHM-3.5-12P-13-00Z(H) (DEGSON)**

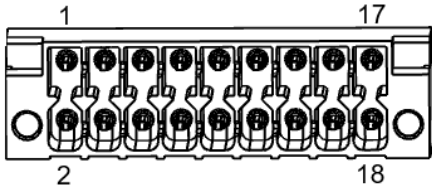

Fig. 18: Analog inputs (U/I) / Analog outputs (U) X11

Analog inputs (U/I) / Analog outputs (U) X11			
Pin	Occupancy	Pin	Occupancy
1	AIN_U4	2	AIN_I4
3	AGND	4	AGND
5	AIN_U3	6	AIN_I3
7	AGND	8	AGND
9	AIN_U2	10	AIN_I2
11	AGND	12	AGND
13	AIN_U1	14	AIN_I1
15	AGND	16	AGND
17	AOUT_U1	18	AOUT_U2

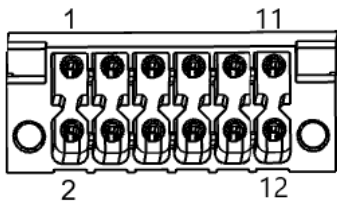

Fig. 19 : Analog inputs (U/I/PT) X12

Analog inputs (U/I/PT) X12			
Pin	Occupancy	Pin	Occupancy
1	AIN_UT4	2	AIN_IT4
3	AGND	4	AGND
5	AIN_UT3	6	AIN_IT3
7	AIN_UT2	8	AIN_IT2
9	AGND	10	AGND
11	AIN_UT1	12	AIN_IT1

Data of the analog inputs (both resolutions)

Data of the analog inputs		
Feature	Value	Description
Cable length	max. 30 m	Applies to unshielded connection cables. For cable lengths over 30 m, the cables must be shielded.
Common points between the channels / Reference potential	AGND	Reference for measurement of all channels at the common AGND reference
Sampling duration/sampling rate for measured values	1 ms	Each input channel is sampled once every millisecond, regardless of how many channels are in operation.
Conversion time PT operating mode	250 ms	In PT mode, calculations are carried out after the calculations are carried out after the sampling duration. A new value is only available in the application program every 250 ms.

Operating modes of the analog inputs with 12-bit resolution

NOTE

Damage to the duct!

A voltage that is too high or too negative can damage the analog input and render it inoperative.

- ▶ Ensure that the input voltage remains in the range -1V...+15V.

Operating mode voltage input AIN (U) of the analog inputs (U/I) X11

Feature	Value	Description
Number of inputs	4	Four separate measuring channels each between AIN_U and AGND. Only one operating mode can be used per measuring channel (i.e. either U or I).
Conversion method	-	Dual slope (switched capacitor)
Measuring range	0...+10 V	-
Input impedance in the signal range	162 kΩ	between AIN_U and AGND Value applies when channel is switched on or off
Input type	-	Voltage measurement unbalanced (single ended)
Max. Error at 25 °C	±0.75 % (±75 mV)	Largest statistically determined measurement deviation
Temperature coefficient	±22 ppm / K (±0.22 mV / K)	related to full scale value
Digital resolution	12 bit	-
Value of the least significant bit	805.6 μV	-
Data format in Application program	32 bit real	(floating point number) in the unit millivolt (mV)
Highest permissible continuous overload	Max. +12 V against AGND	+12 V = max. voltage on AIN channel
Output of the digital value in the event of an overload	-	If a voltage greater than +10 V is applied to an AIN (U), a plausible value is still output up to approx. +12 V. The specified accuracy only applies to the range 0...+10 V. The internal ADC may be damaged if voltages greater than +15 V are applied

Dynamic properties

Operating mode voltage input AIN (U) of the analog inputs (U/I) X11		
Feature	Value	Description
Analog filtering	2nd order low-pass filter, cut-off frequency 240 Hz	-
Largest temporary deviation during electrical interference test according to IEC 61131-2	1.5 % of the measuring range	-

Operating mode current input AIN (I) of the analog inputs (U/I) X11		
Feature	Value	Description
Number of inputs	4	Four separate measuring channels each between AIN_I and AGND. Only one operating mode can be used per measuring channel (either U or I)
Measuring range	0...+20 mA	Technical current direction into AIN_I
Input impedance in the signal range	Type. 50 Ω	between AIN_I and AGND Value applies when channel is switched on or off
Input type	-	Current measurement unbalanced (single ended)
Max. Error at 25 °C	±0.6 % (±120 µA)	Largest statistically determined measurement deviation
Temperature coefficient	±22 ppm / K (±0.44µA / K)	related to full scale value
Data format in Application program	32 bit real	(floating point number) in the unit milliamperes (mA)
Highest permissible continuous overload	Max. 42 mA against AGND	+42 mA = max. current on AIN channel
Output of the digital value in the event of an overload	-	If a current greater than +20 mA is applied to an AIN_I, a plausible value is still output up to approx. +24 mA. The specified accuracy only applies to the range 0...+20 mA. If currents greater than +42 mA are applied, the measuring resistor may be damaged

Dynamic properties		
Analog filtering	2nd order low-pass filter, cut-off frequency 180 Hz	-

Operating mode current input AIN (I) of the analog inputs (U/I) X11

Feature	Value	Description
Largest temporary deviation during electrical Interference test according to IEC 61131-2	1.5 % of the measuring range	-

Operating mode voltage input AIN (U) of the analog inputs (U/I/PT) X12

Feature	Value	Description
Number of inputs	4	Four separate measuring channels each between AIN_UT and AGND. Only one operating mode can be used per measuring channel (i.e. either U or I or T)
Conversion method	-	Delta-sigma conversion
Measuring range	-10...+10 V	-
Input impedance in the signal range	100 kΩ	between AIN_UT and AGND Value applies when channel is switched on or off
Input type	-	Voltage measurement symmetrical (differential)
Max. Error at 25 °C	±0.16 % (±16 mV)	Largest statistically determined measurement deviation
Temperature coefficient	±48 ppm / K (±0.48 mV / K)	
Digital resolution	24 bit	-
Data format in Application program	32 bit real	(floating point number) in the unit millivolt (mV)
Highest permissible continuous overload	Max. ±30 V against AGND	±30 V = max. voltage on AIN channel
Output of the digital value in the event of an overload	-	If a voltage greater than ±10 V is applied to an AIN_UT, a plausible value is still output up to approx. ±15 V. The specified accuracy only applies to the range -10...+10 V. If voltages greater than ±16 V are applied, the values are greatly distorted.
Dynamic properties		
Analog filtering	2nd order low-pass filter, cut-off frequency 650 Hz	-

Operating mode voltage input AIN (U) of the analog inputs (U/I/PT) X12		
Feature	Value	Description
Largest temporary deviation during electrical interference test according to IEC 61131-2	1 % of the measuring range	-

Operating mode current input AIN (I) of the analog inputs (U/I/PT) X12		
Feature	Value	Description
Number of inputs	4	Four separate measuring channels each between AIN_IT and AGND Only one operating mode can be used per measuring channel (either U, I or T)
Measuring range	-20...+20 mA	Technical current direction into AIN_IT
Input impedance in the signal range	Type. 10 Ω	between AIN_IT and AGND Value applies when channel is switched on or off
Input type	-	Current measurement symmetrical (differential)
Max. Error at 25 °C	±0.25 % (±50µA)	Largest statistically determined measurement deviation
Temperature coefficient	±60 ppm / K (±1.2 µA / K)	related to full scale value
Data format in Application program	32 bit real	(floating point number) in the unit milliamperes (mA)
Highest permissible continuous overload	Max. ±25 mA against AGND	-
Output of the digital value in the event of an overload	-	If a current greater than ±20 mA is applied to an AIN_I, a plausible value is still output up to approx. ±25 mA. The specified accuracy only applies to the range -20...+20 mA.

Dynamic properties		
Analog filtering	2nd order low-pass filter, cut-off frequency 600 Hz	-
Largest temporary deviation during electrical interference test according to IEC 61131-2	1 % of the measuring range	-

Operating mode Temperature inputs AIN (PT) of the analog inputs (U/I/PT) X12		
Feature	Value	Description
Number of inputs	4 (2)	Sensor connection between AIN_UT and AGND. Only one operating mode can be used per measuring channel (either U, I or T). (Two AIN_UT channels are used for 3-wire measurement).
Possible sensors	PT100 and PT1000 according to EN 60751	Platinum sensors of accuracy classes AA, A, B and C can be used
Measuring range	-40...+200 °C	-
Measuring current (RMS)	0.6 mA (±0.1%)	-
Conversion time	250 ms	-
Max. Error at 25 °C	±2100 ppm (±0.5 °C)	-
Temperature coefficient	±50 ppm/K (±0.012 °C/K)	-
Digital resolution	24 bit	-
Data format in Application program	32 bit real or 32 bit float	Floating point numbers in the units Ohm (Ω) and Degree Celsius (°C)
Linearization	-	The value in degrees Celsius is calculated from the resistance value and linearized (6th degree polynomial)
Input type	-	2-wire measurement or 3-wire measurement of the platinum temperature probes
Reference potential	AGND	common for all inputs
Dynamic properties		
Analog filtering	2nd order low-pass filter, cut-off frequency 650 Hz	-
Largest temporary deviation during electrical interference test according to IEC 61131-2	1 % of the measuring range	-

Data of the analog outputs

Operating mode of the analog outputs (AOUT) X11		
Feature	Value	Description
Protective device	Thermal overload protection, (short-circuit proof)	Current limitation from approx. 22 mA (at 25 °C ambient temperature)
Insulation voltage between channel and other circuits	None	-
Cable length	max. 30 m	Applies to unshielded connecting cables. Shielded cables must be used for cable lengths over 30 m.
Common points between the channels	AGND	AGND is the reference potential for all analog outputs
Permissible load types	-	Resistive and capacitive loads
Largest capacitive load	10 µF	Larger capacitive loads can cause the output to oscillate.
Max. terminal voltage	12 V	A voltage of more than 12V can damage the analog outputs.
Signal range	0...10 V	-
Load impedance range	> 1 kΩ	(or burden)
Output current	Max. 10 mA	-
Max. Error at 25 °C	±0.25 % (±25 mV)	-
Temperature coefficient	±50 ppm / K (±0.5 mV / K)	-
Value of the least significant bit (LSB)	±291 ppm (±2.91 mV)	-
Digital resolution	12 bit	-
Data format in the user program	32 bit real	Floating point number in the unit millivolt (mV)
Dynamic properties		
Settling time when changing over the full range to 95 % of the final value	typ. 400 µs	-
Overshoot	Up to 1% of the measuring range	typ. < 0.25 % of the measuring range

Operating mode of the analog outputs (AOUT) X11

Feature	Value	Description
Largest temporary deviation during electrical interference test according to IEC 61131-2	Up to 1% of the measuring range	-

Output response of the analog outputs (AOUT) X11

Without supply voltage	AOUT (U) to AGND: < 40 Ω	Low-resistance output
For short-term interruptions	-	If the supply voltage is interrupted for > 10 ms, the analog outputs are switched off.

5.2.5. Connection examples

Voltage output AO (U) on X11

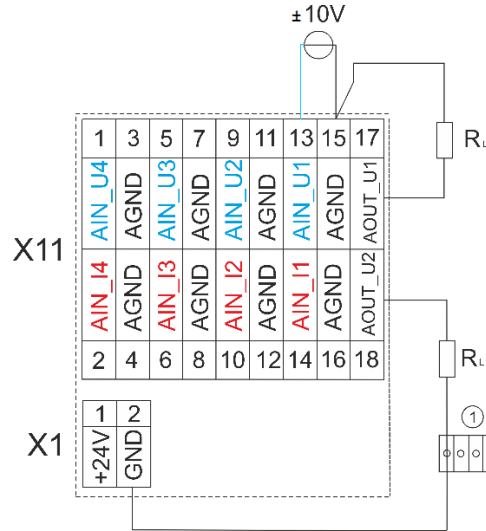

Fig. 20: Connection example: Voltage output AO (U)

Pos.	Description
1	Terminal strip

- ▶ If possible, connect the voltage outputs directly via the load impedance R_L to the AGND of the I/O extension.
If it is not possible to connect directly to AGND: Connect the voltage output to the general GND of the device.
- ▶ Ensure that the line resistances are significantly lower than the load impedance R_L in order to achieve a high output accuracy.
- ▶ Observe the voltage divider between load and line resistance, as well as the input resistance of the measuring device when measuring back.

Voltage input AIN (U) on X11

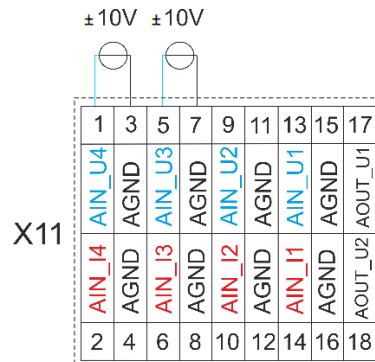

Fig. 21: Connection example: Voltage input AIN_U

- ▶ If possible, only use the nearest AGND for each voltage input.
- ▶ Do not connect AGNDs of several channels. Reverse currents can influence the measurement.
- ▶ Only use one function per channel - either AIN_U or AIN_I.
- ▶ Do not establish a connection to the general GND. The necessary and filtered connections are already available on the circuit board.
- ▶ Lay the cables of the analog sensors/encoders as directly as possible and without detours (avoid intermediate terminals and terminal strips).

Current input AIN (I) on X1

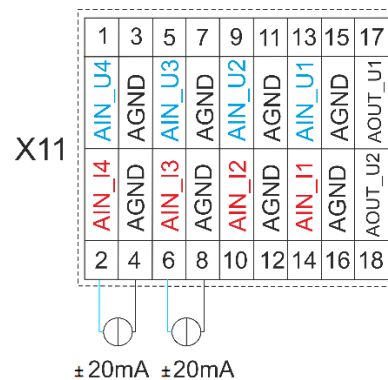

Fig. 22: Connection example: Current input AIN_I

- ▶ If possible, only use the nearest AGND for each power input.
- ▶ Do not connect AGNDs of several channels. Reverse currents can influence the measurement.
- ▶ Only use one function per channel - either AIN_U or AIN_I.
- ▶ Do not establish a connection to the general GND. The necessary and filtered connections are already available on the circuit board.
- ▶ Lay the cables of the analog sensors/encoders as directly as possible and without detours (avoid intermediate terminals and terminal strips).

Temperature measurement AI (PT)

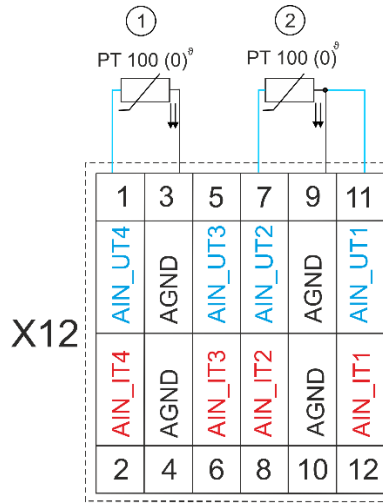

Fig. 23: Connection example: Temperature measurement

Pos.	Description
1	PT 100 with 2-wire connection
2	PT 100 with 3-wire connection

- ▶ Only use the corresponding AGND for each input.
- ▶ Do not connect AGNDs of several channels. Reverse currents can influence the measurement.
- ▶ Do not establish a connection to the general GND. The necessary and filtered connections are already available on the circuit board.
- ▶ If possible, lay the PT100 or PT1000 sensor cables directly and without detours (avoid intermediate terminals and terminal strips).
- ▶ Only connect PT100 or PT1000 sensors to the AIN_UT channels.

2-wire measurement

The cable resistance results in a measurement error that can be up to 10 Kelvin for long cables and small cable cross-sections. If the temperature of the sensor is known, this deviation can be subtracted and compensated for via the software (alternatively, realize the connection using 3-wire measurement).

3-wire measurement

The nearest connection AIN_UT is used to compensate for the line resistance. Only the channel directly following the AIN_UT can be used. Channels 1 and 2 as well as channels 3 and 4 are each a suitable pair for 3-wire measurement.

5.2.6. Ethernet

The onboard Ethernet adapter has two 1000/100/10-Base-T with RJ-45 connections for the network connection X3 and X4

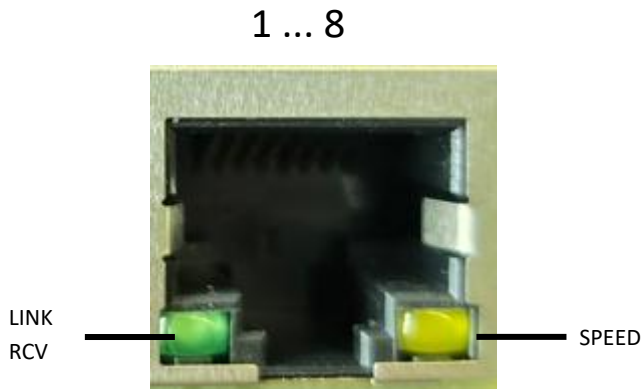

Fig. 24: Ethernet interface X3 and X4

Assignment of Ethernet interface connectors X3 and X4			
Pin	Occupancy	Pin	Occupancy
1	BI_DA+ Bidirectional pair A+	5	BI_DB- Bidirectional pair B-
2	BI_DA- Bidirectional pair A-	6	BI_DC- Bidirectional pair C-
3	BI_DB+ Bidirectional pair B+	7	BI_DD+ Bidirectional pair D+
4	BI_DC+ Bidirectional pair C+	8	BI_DD- Bidirectional pair D-

LEDs		
LED	Color	Meaning according to IEEE 802.3 clause 25
LNK/RCV	Green	Link, Data Receive Flashing: Connection is active, data transmission is running Off: no connection established
SPEED	Yellow	On = 1000 Mbit/s On = 100 Mbit/s Off = 10 Mbit/s

5.2.7. USB

Devices with an USB interface can be connected to the two USB host ports.

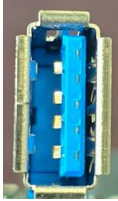

Fig. 25: USB interfaces X5 and X6

NOTE

Damage to USB stick and malfunction due to data loss!

Removing a USB stick while it is still in use and data is being transferred can render the USB stick unusable. Open files which can no longer be accessed because the USB stick has been removed can block the device.

- ▶ Therefore, ensure that all operations are complete before removing the USB stick.

NOTE

Damage to property and malfunctions due to data loss!

The USB interface is protected against overloading (see USB interfaces max. current → p. 66). In the event of a short circuit during operation, the control unit may trigger a reset of the system.

Substantial property damage and damage to the USB device may ensue.

- ▶ Before using a USB device, check carefully its power requirements

NOTE

Failures and malfunctions will occur if direct connections are made to signal earth!

- ▶ Use only USB devices that have no direct connection between signal earth and the housing



The USB interface plug is designed to withstand 1,000 plugging and unplugging cycles.

5.2.8. CAN bus

Properties of the CAN interface X8	
Standard	ISO 11898
Maximum baud rate	1 MBit/s
Lowest adjustable baud rate	50 kBit/s
Contacts	Galvanically isolated
Occupancy	according to CiA303

1 ... 8

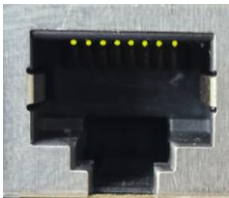

Fig. 26: CAN interface X 8

Assignment of CAN interface connector X8			
Pin	Occupancy	Pin	Occupancy
1	CAN_H	5	NC
2	CAN_L	6	NC
3	ISO GND	7	ISO GND
4	NC	8	NC

If the CAN interface is at the beginning or end of the CAN bus topology:

- Set switch S2 to ON to switch on the terminating resistor of 120 Ω between CAN_L and CAN_H.

Switch position

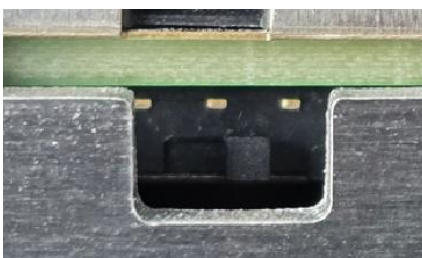

OFF ON

5.2.9. Serial interfaces

The module has two serial communication interfaces (1x RS-232 and 1x RS-485), which are connected via the common RJ45 connector X7.

Maximum baud rate of both interfaces: 115.2 kBit/s

1 ... 8

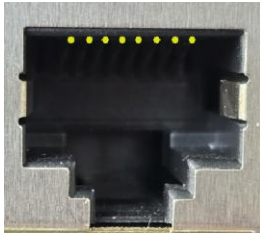

Fig. 27: RS-232 / RS-485 interface X7

Assignment RS-232 / RS-485 interface connector X7			
Pin	Assignment / software interface	Pin	Assignment / software interface
1	RS-232 RX / COM1	5	RS-485 Tx/Rx- / COM2
2	RS-232 TX / COM1	6	NC
3	NC	7	(reserved)
4	RS-485 Tx/Rx+ / COM2	8	ISO GND

The RS-485 interface is "softly" terminated with 680 Ω (polarization).

If the interface is at the beginning or end of the bus topology:

- ▶ Set switch S3 to ON to switch on the differential terminating resistor of 120 Ω

Switch position

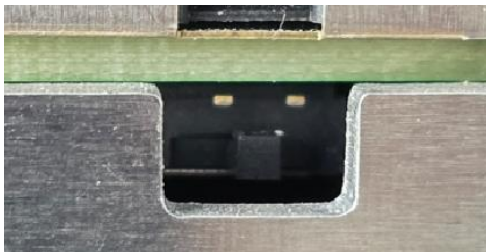

OFF ON

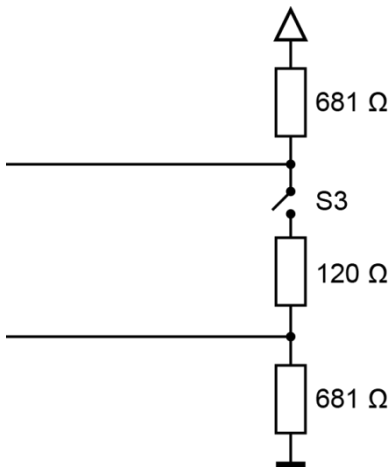

Fig. 28: RS-485 switchable terminating resistor

i The assignment of the interface is largely based on the specifications of the "MODBUS over Serial Line; Specification and Implementation Guide V1.02".

Signal interference and terminating resistor

The following instructions must be observed to minimize interference.

Driven bus

- A suitable protocol must ensure that one of the bus participants is actively driving the bus at all times.
- For a high symmetrical signal-to-noise ratio, the bus must have defined states for logic "1" ($A-B < -0.2\text{ V}$) and for logic "0" ($A-B > +0.2\text{ V}$).

Unpowered bus

- A bus termination that is as unbalanced as possible must ensure a sufficiently large signal-to-noise ratio (reduce the balanced signal-to-noise ratio).
- In order to achieve the necessary voltage difference between the signals, a suitable resistor network must be used as a line termination.
- The required values of the resistors depend on the bus length and transmission rate (similar to the line termination for Profibus, see DIN EN 61158-2).

Connections with GND

To minimize common mode interference or malfunctions due to potential differences:

- ▶ Check the topology and cable lengths to see whether additional connections with GND are necessary.
- ▶ For electrically isolated interfaces with connection to the reference earth at one point: Carry GND.
- ▶ If required, ensure a damped connection of GND at several points on the bus (e.g. via $200\ \Omega$).

6. Operation

6.1. Switching on and off

NOTE

Damage or malfunction!

- ▶ Do not insert, connect, undo or touch any connections whilst the device is in operation.
- ▶ Before starting any work on the device, switch off all power feeds, including those to any connected peripherals (sensors and programmable devices etc. with independent power supplies).

NOTE

Damage to property!

- ▶ Before connecting the power supply, ensure that all cabling and the polarity of all the connections are correct.

Switch on

The device does not have an on/off switch. The device starts automatically when the system is switched on or the power is connected.

Switch off

The device is switched off when the system is switched off or the power supply is disconnected.

6.2. Initial commissioning network

6.2.1. Standard commissioning

The DC-Pi Open devices come with a pre-installed Raspberry Pi OS and are configured accordingly, just like any other Raspberry Pi.

A detailed overview of commissioning in the Raspberry Pi OS can be found here:

<https://www.raspberrypi.com/documentation/computers/>

For easy commissioning, it is recommended to use DC-Pi devices with a connected keyboard and mouse and to use the desktop interface of Raspberry Pi OS, alternatively the Linux terminal can be used.

The network interfaces on the DC-Pi devices are configured as DHCP clients by default and are automatically assigned an IP address when they are connected to a network with a DHCP server (e.g. a router).

The assigned IP is listed in the client overview of the DHCP server or can be looked up in the Raspberry Pi OS and assigned statically if necessary.

6.2.2. Commissioning via SSH terminal

If no additional peripherals are available for the commissioning of a DC-Pi Open device, it is possible to activate the SSH server in the DC-Pi with the help of a Windows PC in order to access the Linux terminal of the Raspberry Pi OS via the network.

1. Download the "rpiboot" tool at <https://www.raspberrypi.com/documentation/computers/compute-module.html#compute-module-4>.
2. Install the tool and the integrated drivers on your PC.
3. Connect a commercially available micro USB cable to X15 USB2.0/Boot of the DC-Pi and connect it to the PC.
4. Supply the DC-Pi with 24V DC voltage, Windows should now recognize a new hardware and install the driver.
5. After installing the driver, run the installed "RPiBoot.exe" tool.
6. After a few seconds, the DC-Pi is displayed as a mass storage device under Windows.
7. Open the mass storage drive with Windows Explorer and create an empty file with the name "ssh" (without file format extension).
8. Optional: If no DHCP server is available, you can give the DC-Pi a static IP by making an entry in "cmdline.txt".
9. Optional: Open the "cmdline.txt" and add the following syntax code to the line (only one space, without line break):

```
ip=<client-ip>:<server-ip>:<gw-ip>:<netmask>:<hostname>:<interface>:<autoconf>
```

 A simple IP configuration looks like this as an example:

```
ip=192.168.1.100:::255.255.255.0:bc-pi:eth0:off
```

 Then save the changes and close the file.
10. Switch off the DC-Pi and remove the micro USB cable.

11. After a restart the SSH server is activated, and you can access the Linux terminal of the Raspberry Pi OS via the IP address set in the DC-Pi.

6.3. Operation

6.3.1. Status displays

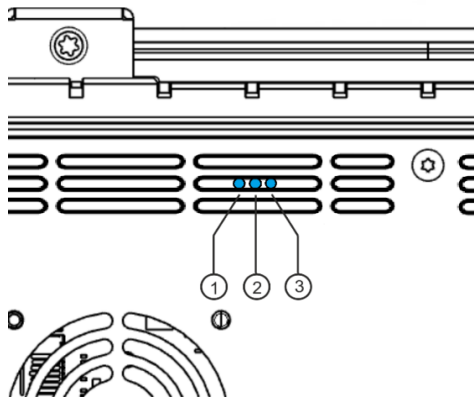

Fig. 29: Positions of the operating status LEDs

The current status of the power supply is displayed via the power status LED. The 2 other LEDs are freely available and are supported by the LED framework.

LED		Function
1	PWR (blue)	ON = correct supply voltage for the module electronics
2	Dualcolor LED	Freely usable (led-green/led-red1)
3	Standard LED	Freely usable (led-red2)

6.3.2. Real-time clock with voltage buffer

The DC-Pi series is equipped with a real-time clock. The buffer time is 30 days.

6.3.3. μ SD card

⚠ WARNING

Serious injuries due to unregulated, unpredictable operating procedures!

Inserting or removing the μ SD card can lead to malfunctions in the device. Malfunctions in electronic control systems can lead to an uncontrolled and unpredictable operating sequence.

- ▶ Only insert or remove a μ SD card when the device is switched off.

Insert μ SD card

1. Switch off the device.
2. Insert the μ SD card into the μ SD card slot.
3. Switch the device back on.

Depending on the operating system used, the μ SD card is ready for data transfer (writing, reading and copying) or still needs to be mounted.

NOTE**Suitable μ SD cards**

The device supports all SDHC and SDXC μ SD cards from variant S02 onwards.



Maximum possible storage capacity of a μ SD card 2 TB.

The service life of the gold-plated contacts is up to 10,000 mating cycles.

The μ SD card drive has a push-in/push-out plug-in and eject mechanism.

To avoid malfunctions, the μ SD card must not be removed by pulling it out.

6.3.4. Push-button S1

Fig. 30: Function button (S1)

The S1 button is located on the left-hand side of the device.

It can be used freely via the GPIOs (`sps_tast_pin`). To prevent unintentional actuation, the button can only be actuated with a pointed object (ballpoint pen, screwdriver).

6.3.5. Interfaces

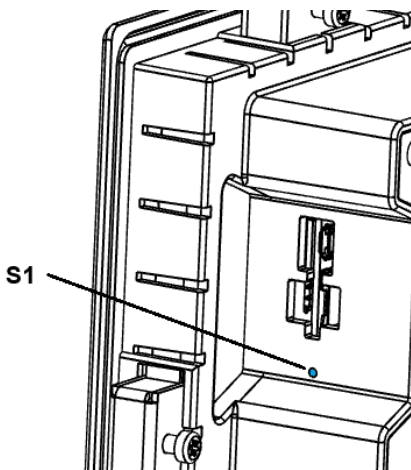
The RS 232 interface can be addressed under `/dev/ttyAMA2`, the RS485 interface under `/dev/ttyUSB0` and the CAN interface as network interface `can0`. A Python module is available for the analog and digital inputs and outputs.

Analog and digital inputs and outputs

The Python module `xpio_control` can be used to access both the digital and analog I/O's. The `xpio` class with the following functions (methods) is available for this purpose. An I/O watchdog is implemented for monitoring, which is set to 1000 cycles by default. This can be set to a different value using the `__init__` method.

Function	Description
<code>read_digital_in</code>	Returns the value of the digital inputs. Bit 16 indicates whether the power supply is present.
<code>write_digital_out</code>	Sets the digital outputs to the specified value. Bit 16 controls the beeper.
<code>setconfig_analog_in_U_I</code>	Configures the specified analog output to the specified mode 1 XPI_ADC_U 2 XPI_ADC_I
<code>setconfig_analog_in_U_I_PT</code>	Configures the specified analog output to the specified mode 1 XPI_ADC_U 2 XPI_ADC_I 3 XPI_ADC_PT100_2 4 XPI_ADC_PT100_3 5 XPI_ADC_PT1000_2 6 XPI_ADC_PT1000_3
<code>disablePTConversion</code>	Deactivates the PT conversion of the analog inputs. (Display in ohms, only valid in mode 3-6)
<code>enablePTConversion</code>	Activates the PT conversion of the analog inputs. (Display in °C, only valid in mode 3-6, active by default)
<code>read_analog_in_U_I</code>	Returns the value [mV, mA], mode and status of the specified analog input.
<code>read_analog_in_U_I_PT</code>	Returns the value [mV, mA, °C], mode and status of the specified analog input.
<code>write_analog_out</code>	Sets the specified analog output to the specified value [mV].
<code>readstate</code>	Returns the XPIO status and must be called cyclically to trigger the I/O watchdog. The status must be XPIO_STATE_IO_OPERATIONAL before reading or writing. 0 XPIO_STATE_IDLE 1 XPIO_STATE_TX_CONFIG 2 XPIO_STATE_TX_CONFIG_ACK 3 XPIO_STATE_TX_OPERATIONAL 4 XPIO_STATE_TX_OPERATIONAL_ACK 5 XPIO_STATE_IO_OPERATIONAL 6 XPIO_STATE_IO_ERROR 7 XPIO_STATE_USB_RECONNECT 8 XPIO_WD_ELAPSED

reinit	Restarts the communication. (Necessary according to XPIO_WD_ELAPSED)
--------	---

NOTE

The XPIO Python module does not fulfill any real-time requirements!

- ▶ A suitable IO control must be used for real-time requirements.
-

6.4. Troubleshooting

6.4.1. No network connection

- ▶ Check cabling/switch.
- ▶ Check whether a DHCP server is available in the network.
- ▶ Check the firewall/anti-virus programs on the PC.

7. Maintenance / servicing

Repairs and maintenance may only be carried out by the manufacturer or its authorised customer service.

7.1. Maintenance

WARNING

Uncontrolled and unpredictable operational behavior!

Failures or malfunctions may result in uncontrolled and unpredictable operational behavior.

- ▶ Do not insert, connect, undo or touch any connections whilst the device is in operation.
- ▶ Before starting any work on the device, switch off all power feeds, including those to any connected peripherals (sensors and programmable devices etc. with independent power supplies).

If the device is used correctly, it should not require maintenance.

- ▶ Make sure all the ventilation holes are kept free of obstructions.
- ▶ Do not open the device. Contact the customer service if work is required on the device.

7.2. Cleaning

NOTE

Damage to the device

The front panel is of glass and must not be exposed to any mechanical or chemical stress.

- ▶ Do not use any high-pressure cleaners or steam jets.
 - ▶ Do not use any corrosive cleaning products, any thinners, any abrasive media or any hard objects.
 - ▶ Do not apply any undue force to the front face. Do not bend the device.
 - ▶ Do not place any heavy, hard or sharp-edged objects on the device.
 - ▶ Do not dismantle the devices.
-
- ▶ To prevent malfunctions due to unintentional operation, switch off the appliance to clean the front panel.
 - ▶ Only clean surfaces with a dry, lint-free cloth.
 - ▶ Only clean the display glass with normal window cleaning agents or alcohol-based solutions.

8. Uninstallation

1. Disconnect the device and associated peripherals from the power supply.
2. Disconnect all connectors and cables.

NOTE

Damage to the device!

If uninstallation is performed carelessly the device can fall out of the installation cut-out or be damaged.

- ▶ Do not tilt the device.
- ▶ Secure the device against falling, especially when taking it out of the installation cut-out.

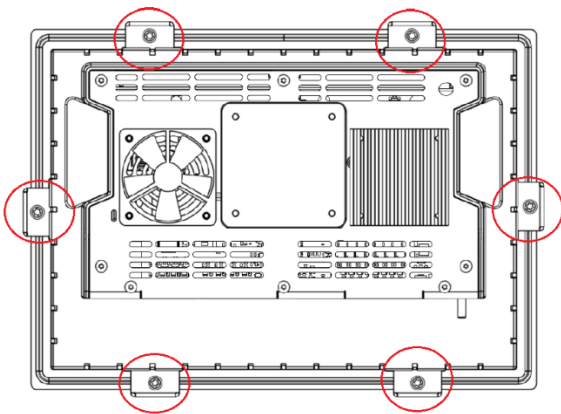

DC-Pi Prime Open 7 / 10

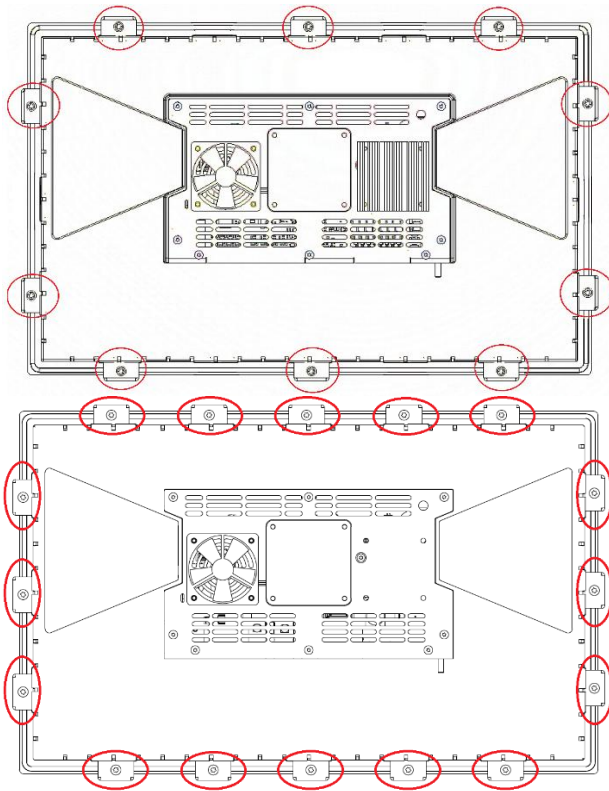

DC-Pi Prime Open 15

IP54: 10 securing clips,
standard features

IP65: 16 securing clips,
expansion pack required:
order no. S-02060201-0100

Fig. 31: Loosening the screws

Undo the screws on all the securing clips equally

DC Pi Prime Open 7" / 10": 6x securing clip

DC-Pi Prime Open 15": 10x securing clip for IP54 / 16x securing clip for IP65

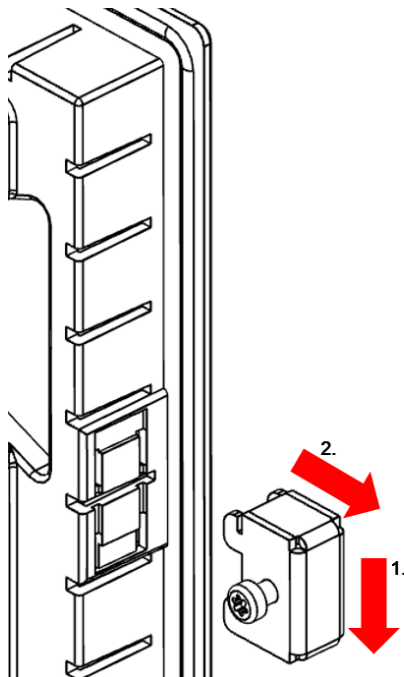

Fig. 32: Removing the securing clip

3. Remove the securing clips.

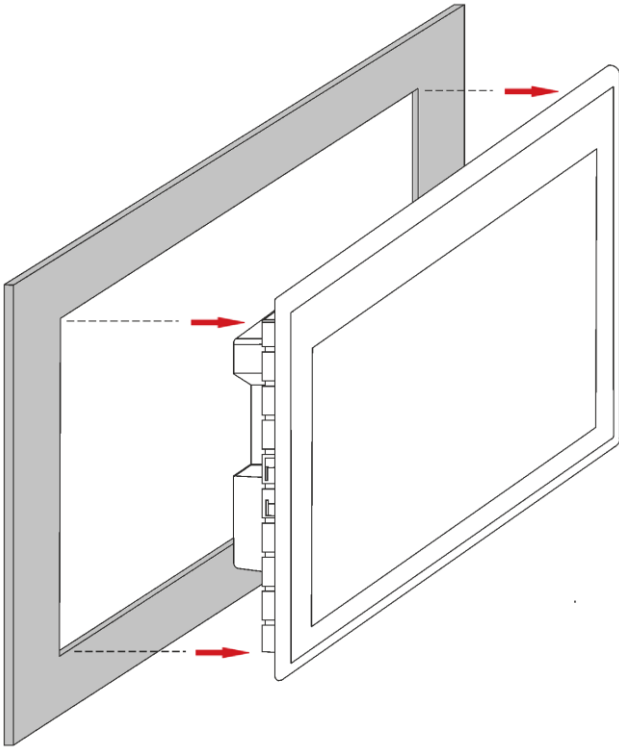

Fig. 33: Sliding the device out of the installation cut-out

4. Push the device evenly forwards out of the installation cut-out

9. Waste disposal

The device contains the following components which need to be disposed of separately:

- Metals
- Electronic components

The respective national regulations for disposal of electrical devices in B2B trade are applicable.

The following options are available for disposal of the device:

Disposal by the manufacturer

Unless agreed otherwise, devices can be sent back for disposal.

Disposal in accordance with regional regulations

- ▶ Dismantle the device and disassemble it completely into its component parts.
- ▶ Send the metal parts for metal recycling.
- ▶ Sort the electronic parts (circuit boards, drives etc.).
- ▶ Dispose of the electronic scrap in accordance with the national laws and regulations

10. Information and options

Dialog Controller	DC-Pi Prime Open 15	DC-Pi Prime Open 10	DC-Pi Prime Open 7
Display	Full HD	WXGA	WVGA
Item no.	S-01010403-xx08	S-01010403-xx05	S-01010403-xx04
Display diagonal	15,6"	10.1"	7"
Resolution	1920 x 1080 pixels	1280 x 800 pixels	800 x 480 pixels
Colors	TFT: 16.7 M (24 bit/pixel)		
Brightness	0 - 800 cd/m ³ adjustable		
CPU, user memory			
CPU	Raspberry Pi CM4 (1.5GHz Quad Core)		
Program memory (flash)	8GB to 32GB eMMC		
Data memory (RAM)	1GB to 8GB		
Retain memory (FRAM)	100 kB		
Sizes and weights			
Dimensions (WxHxD)	403.7 x 253.1 x 69.8 mm	262 x 186 x 69.3 mm	207.5 x 146.5 x 69.3 mm
Weight	2.5 kg	1.2 kg	1 kg
Operating conditions			
Ambient temperature	If the installation instructions are observed, the following applies to the front and rear of the device:		
Operation			
passively cooled	-10 °C to +55 °C	-10 °C to +55 °C	
with fan	-10 °C to +60 °C	-10 °C to +65 °C	
Relative humidity	max. 85 %, non-condensing		
Transportation, storage			
Ambient temperature	-20 °C to +70 °C		
Relative humidity	max. 85 %, non-condensing		
Operation			
Assembly	Switch cabinet installation using a securing clip Optional VESA mount		
Certifications	CE, UKCA, optionally available: UL, in preparation: FCC		

Dialog Controller	DC-Pi Prime Open 15	DC-Pi Prime Open 10	DC-Pi Prime Open 7
Visualization	Integrated display		
Touch operation	Capacitive, multi-touch		
Vibration resistance			
Vibration	Sinusoidal (EN 60028-2-6) Test: Fc 10...150 Hz, 1G (operation mode)		
Shock	15 G (approx. 150 m/s ²), 10 ms duration, half-sine (EN 60068-2-27) Examination: Ea		
EMC, protection class			
EMC Emission	IEC 61000-6-3:2022-06, residential area		
EMC Immunity	IEC 61000-6-2:2019-11, industrial area		
Protection class	III		
Insulation resistance	SELV (Ue < 30V) according to EN 61131-2, 500 VDC test voltage		
Protection category	Rear IP20 (not evaluated by UL), Front IP54 (not evaluated by UL) with 10 securing clips, Front IP65 (not evaluated by UL) with 16 securing clips	Rear IP20 (not evaluated by UL), Front IP65 (not evaluated by UL) 6 securing clips	Rear IP20 (not evaluated by UL), Front IP65 (not evaluated by UL) 6 securing clips
UL Enclosure Type	Type 1		
Power supply (24 V power supply unit)			
Supply voltage	+24 V DC (-20 % / +25 %) SELV max. AC voltage component 5%		
Power consumption	max.1.2 A at +24 V DC	max.0.8 A at +24 V DC	max.0.8 A at +24 V DC
Current consumption digital Outputs	Depending on output load, max. 4 A (8 x 0.5A)		
Reverse polarity protection	Integrated		
Ethernet interfaces			
Number / type of interface	2x 10/100/1000 Base T		
Connection technology	RJ45		
CAN bus interface			

Dialog Controller	DC-Pi Prime Open 15	DC-Pi Prime Open 10	DC-Pi Prime Open 7
Number / type of interface	1x CAN bus		
Connection technology	RJ45		
Serial interfaces			
Number / type of interface	1x RS-232 / 1x RS-485		
Connection technology	RJ45, RS-232 and RS-485 combined		
USB interfaces			
Number / type of interface	2x USB 3.2Gen. / Host USB connector Port A		
Max. amperage	0.5 A per port		
Number of mating cycles	max. 1000		
Further functions			
Real-time clock	Yes, battery-buffered (30 days buffering), accuracy +/- 7ppm		
microSD card slot	1x microSD card slot (SDHC and SDXC) (S02 and higher)		
Expansion slots	2x M.2 (S02 and higher) (Optional memory expansion, interface expansion, AI hardware acceleration)		
Hardware	Optional: Watchdog for system monitoring		
Beeper	Optional extension		
Heat sink and fan	Optional extension		
Inputs / Outputs			
Digital I/O	8x digital input (type 1 / 3; 1ms)		
	8x digital output (rated current: 0.5 A per output; 1ms)		
Analog inputs	Up to 4x analog-in measuring channels for current / voltage (0...+10 V, 0...+20 mA) Resolution: 12 bit, internal filtering configurable		
	Up to 4x high-precision analog-in measurement channels for current / voltage (-10 V...+10 V, -20 mA...+20 mA, 4x PT100 / PT1000 2-wire or 2x PT100 / PT1000 3-wire) Resolution: 24 bit, internal filtering configurable		
Analog outputs	Up to 2x analog-out voltage sources Resolution 12 bit (0...10 V, loadable up to min. 1 kOhm impedance)		

10.1. Device variants DC-Pi Prime Open 7 / 10 / 15

	Variants		
	S01	S02	S04
CAN	-	x	x
RS 232	-	x	x
RS 485	-	x	x
USB 2.0	x	-	-
USB 3.2 Gen 1	-	x	x
8x digital input	-	-	x
8x digital output	-	-	x
4x analog input (12 Bit) 4x analog input (24 Bit)	-	-	x
2x analog output	-	-	x
MicroSD-Card-Slot	-	x	x
Beeper	-	-	x
Order option fan	x	x	x
Order option SSD	-	x	x
Order option AI Accelerator	-	x	x

10.2. Type plate

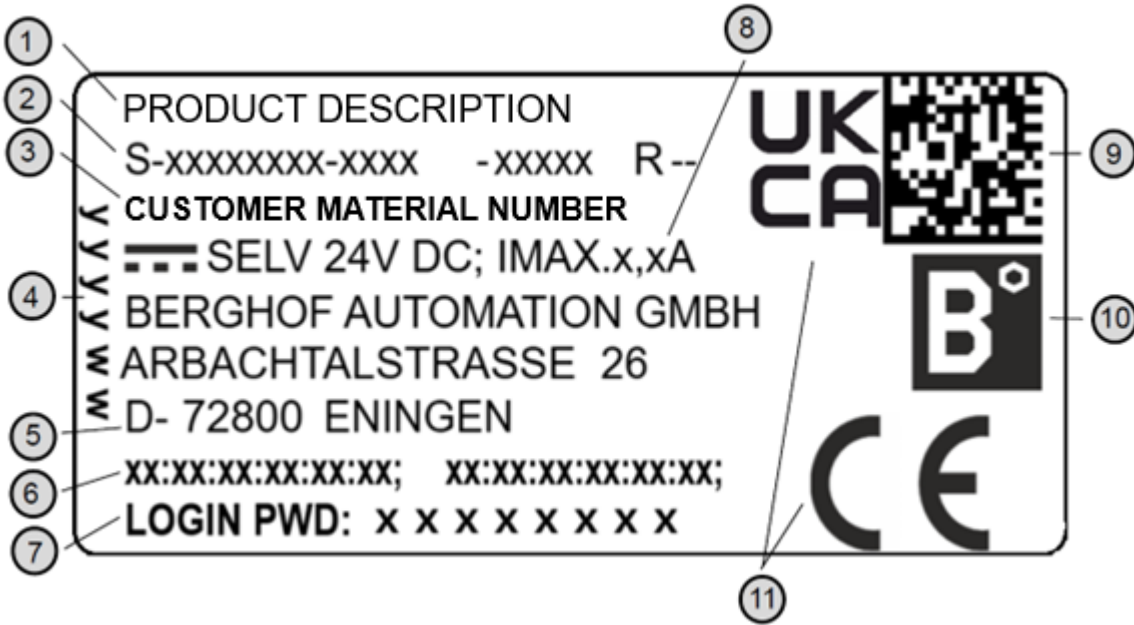

Fig. 34: Type plate

Pos.	Designation	Pos.	Designation
1	Product name	7	Default password
2	Order no. / Serial no. / Revision	8	Supply voltage and maximum amperage
3	Customer material number	9	QR code (identification number)
4	Production date (year/week)	10	Logo of the manufacturer
5	Manufacturer (manufacturer address)	11	Conformity marking
6	MAC addresses of the device		

10.3. Device variants and identification

Designation	Order number
DC-Pi Prime Open 7 S01	S-01080203-0104
DC-Pi Prime Open 7 S02	S-01080203-0204
DC-Pi Prime Open 7 S04	S-01080203-0404
DC-Pi Prime Open 10 S01	S-01080203-0105
DC-Pi Prime Open 10 S02	S-01080203-0205
DC-Pi Prime Open 10 S04	S-01080203-0405
DC-Pi Prime Open 15 S01	S-01080203-0108
DC-Pi Prime Open 15 S02	S-01080203-0208
DC-Pi Prime Open 15 S04	S-01080203-0408

10.4. Options and extensions

The options are ordered via the compilation
 "Order number Option1 Option2 ..."

e.g.: **S-01010403-0205 S001 S002 H001**

In addition to the order number, additional extensions in the form of hardware, software and customer-specific options are identified as follows:

Option code	Option type
S000-S999	Software options e.g. field buses
H000-H999	Hardware options e.g. plug replacement, certifications
C000-C999	Customized options e.g. customized firmware, customized front foil

For more information on the options available for this device, please refer to the product catalog or the homepage.

The additional features included or installed in the respective device are listed in the option label. This label can be found on the device and/or on the packaging.



Fig. 35: Option label

11. Standards and certificates

11.1. Standards

EU directives applied

- EMC Directive 2014/30/EU
- RoHS Directive 2011/65/EU (also 2015/863/EU)

EU standards applied

- Technical documentation for the assessment of electrical and electronic equipment with regard to the restriction of hazardous substances
EN 63000:2019-05
- Programmable logic controllers - Part 2: Equipment requirements and tests
EN 61131-2:2007
- Electromagnetic compatibility (EMC) - Part 6-4: Generic standards - Emission for industrial environments (IEC 61000-6-4: 2018)
EN IEC 61000-6-4:2020-09
- Electromagnetic compatibility (EMC) - Part 6-2: Generic standards - Immunity for industrial environments (IEC 61000-6-2: 2019)
DIN EN 61000-6-2:2019-11

UKCA guidelines applied

- EMC Directive from 2012
UK S.I. 2012 No. 3032
- RoHS Directive 2016
UK S.I. 2016 No. 1091

UKCA standards applied

- Technical documentation for the assessment of electrical and electronic equipment with regard to the restriction of hazardous substances
BS EN IEC 63000:2018
- Programmable logic controllers - Operational requirements and tests
BS EN 61131-2:2007
- Electromagnetic compatibility (EMC) - Part 6-4: Generic standards - Emission for industrial environments
BS EN IEC 61000-6-4:2019
- Electromagnetic compatibility (EMC) - Part 6-2: Generic standards - Immunity for industrial environments
BS EN IEC 61000-6-2:2019

11.2. Declaration of conformity

The declarations of conformity, technical data and further information can be found on our website at <https://www.berghof-automation.com/downloads/>

Select the relevant area (automation technology) and complete the form. Information on data protection can also be found on the page.

12. Customer service / Addresses

Repairs and maintenance may only be carried out by the manufacturer or its authorized customer service.

12.1. Customer service

Berghof Automation GmbH
Arbachtalstrasse 26
72800 Eningen
Germany
T +49.7121.894-183
E-mail: support-controls@berghof.com
www.berghof-automation.com

12.2. Repair service

Please send the goods to the Berghof Repair Service for repair, quoting the RMA number and giving a detailed description of the fault.

Berghof Automation GmbH
BU Automation Technology
Repair service
Arbachtalstrasse 26
72800 Eningen

You can request the RMA number at:
www.berghof-reparaturservice.com

12.3. Addresses

CAN in Automation; international manufacturer and user organization for CAN users in automation:

CAN in Automation e.V. (CiA)

Am Weichselgarten 26

91058 Erlangen

headquarters@can-cia.de

www.can-cia.de

DIN Media Verlag GmbH, 10787 Berlin

or

VDE-Verlag GmbH, 10625 Berlin

or

Research via the Internet: www.iec.ch

13. Appendix

13.1. Notes on copyright and license of the software

The firmware of the devices contains free software. Parts of this software are available under the following and other OpenSource licenses:

- GNU General Public License (GPL)
- GNU Lesser General Public License (LGPL)
- Mozilla Public License (MPL)
- FreeType License (FTL)

The source code of the free software can be requested from Berghof customer service at cost price within three years of delivery of the device.

13.2. List of illustrations

Fig. 1: Overview of B-Primis DC-Pi Prime Open 10 S01 (back).....	15
Fig. 2 : Overview of B-Primis DC-Pi Prime Open 10 S02-S04 (back)	15
Fig. 3 : Dimensions DC-Pi Prime Open 7.....	19
Fig. 4: DC-Pi Prime Open 7 mounting cut-out.....	20
Fig. 5 : Dimensions DC-Pi Prime Open 10.....	21
Fig. 6: DC-Pi Prime Open 10 mounting cut-out.....	22
Fig. 7 : Dimensions DC-Pi Prime Open 15.....	23
Fig. 8: DC-Pi Prime Open 15 mounting cut-out.....	24
Fig. 9: Inserting into the mounting cut-out.....	25
Fig. 10: Fitting the securing clip.....	26
Fig. 11: Tighten the securing clip	27
Fig. 12: Power supply X1	29
Fig. 13 : Block diagram DC-Pi Prime Open.....	30
Fig. 14: Digital inputs and outputs X10.....	32
Fig. 15: Principle circuit diagram output, positive switching	34
Fig. 16: Principle circuit diagram input, positive switching.....	35
Fig. 17: Operating ranges of the digital inputs (type 1/3).....	35
Fig. 18: Analog inputs (U/I) / Analog outputs (U) X11	37
Fig. 19 : Analog inputs (U/I/PT) X12.....	37
Fig. 20: Connection example: Voltage output AO (U)	46
Fig. 21: Connection example: Voltage input AIN_U	47
Fig. 22: Connection example: Current input AIN_I.....	47
Fig. 23: Connection example: Temperature measurement	48
Fig. 24: Ethernet interface X3 and X4	49
Fig. 25: USB interfaces X5 and X6.....	50
Fig. 26: CAN interface X 8	51
Fig. 27: RS-232 / RS-485 interface X7.....	52
Fig. 28: RS-485 switchable terminating resistor.....	53
Fig. 29: Positions of the operating status LED s.....	56
Fig. 30: Function button (S1).....	57
Fig. 31: Loosening the screws.....	62
Fig. 32: Removing the securing clip	63

Fig. 33: Sliding the device out of the installation cut-out 63
Fig. 34: Type plate 69
Fig. 35: Option label 71