

# B-PRIMIS ET-Pi PRIME Series

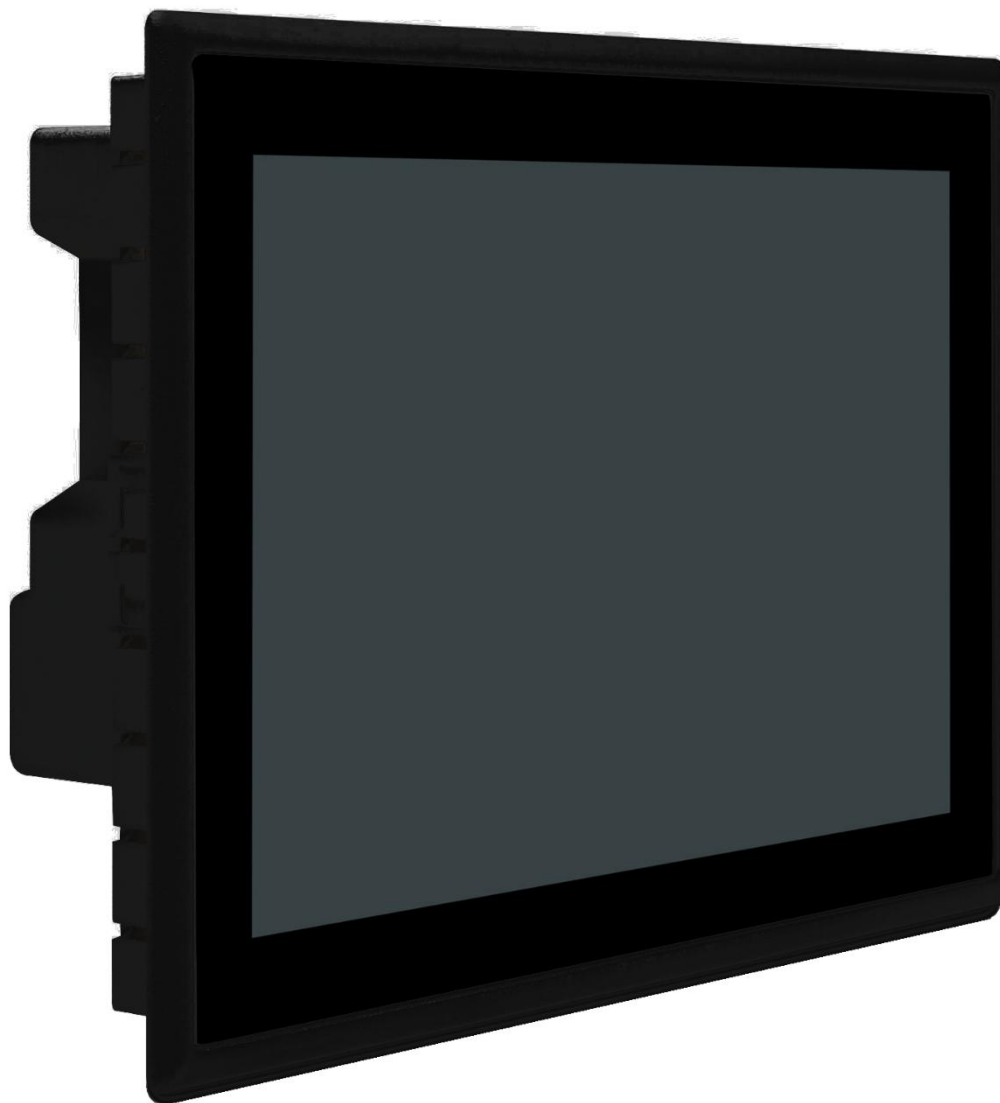

Copyright © Berghof Automation GmbH

The distribution and reproduction of this document, as well as the use and communication of its contents, is not permitted without our express consent. All rights reserved.  
Violations will result in liability for damages.

### **Disclaimer**

The content of this publication has been checked for compliance with the hardware and software described. However, deviations cannot be ruled out, so we cannot guarantee complete compliance. The information in this publication is checked regularly, and any necessary corrections are included in subsequent editions. Suggestions for improvement are always welcome. Subject to technical changes.

### **Trademarks**

- Modbus® is a registered trademark of the Modbus-IDA Organization.
- Raspberry Pi is a registered trademark of the Raspberry Pi Foundation.

The rights to all companies and company names mentioned here, as well as goods and product names, are held by the respective companies.

### **Notes on this manual**

This manual:

- contains product-specific information that is valid at the time of publication.
- should be read carefully before using the device to avoid errors during operation and to familiarize yourself with the device.
- It is only complete when used in conjunction with the product-related hardware and software user manuals required for the respective application.
- does not contain repair instructions. If repairs are necessary, please contact your supplier or Berghof Automation GmbH directly.

You can reach us at:

Berghof Automation GmbH

Arbachtalstrasse 26

72800 Eningen

Germany

T +49.7121.894-0

E-mail: [controls@berghof.com](mailto:controls@berghof.com)

[www.berghof-automation.com](http://www.berghof-automation.com)

Berghof Automation GmbH is certified according to DIN EN ISO 9001.

## Change log

Version	Date	Description
1.0	Apr. 23, 2025	Initial version
1.1	Sept. 16, 2025	Revision
1.2	March 23, 2026	Correction of the number of securing clips with 15” Adjustment Certification DIN EN ISO 9001 Information regarding UL certification added
1.3	12.06.2026	Correction Power consumption DC-Pi Prime 15 Information regarding UL certification and Protection category added

## Table of contents

<b>1.</b>	<b>GENERAL INFORMATION</b> .....	<b>7</b>
1.1.	Notes on the manual.....	7
1.2.	Symbols and illustrations sm .....	8
1.3.	Hazard categories and signal words.....	8
1.4.	Qualified personnel .....	9
1.5.	Duty of care .....	9
1.5.1.	General .....	9
1.6.	Intended use.....	10
1.7.	Transport and storage .....	11
	Transport and storage.....	11
	Operation .....	11
1.8.	Unpacking.....	11
<b>2.</b>	<b>SAFETY</b> .....	<b>12</b>
2.1.	Safety-related systems.....	12
2.2.	Safety instructions.....	12
	Working on the device .....	13
2.3.	Cyber security.....	13
<b>3.</b>	<b>PRODUCT DESCRIPTION</b> .....	<b>14</b>
3.1.	Overview ET-Pi Prime 7/10/15.....	15
3.2.	Scope of delivery and accessories .....	16
	Scope of delivery .....	16
	Accessories.....	16
3.3.	Product features .....	16
	Performance features at a glance.....	16
	Mounting .....	16
	Processor.....	16
	Ethernet .....	16
	USB.....	16
	Real-time clock.....	16
<b>4.</b>	<b>INSTALLATION</b> .....	<b>17</b>
4.1.	Installation preparation Front installation ET-Pi Prime 7 .....	17
4.2.	Installation preparation for front installation ET-Pi Prime 10 .....	19
4.3.	Installation preparation Front installation ET-Pi Prime 15 .....	21
4.4.	Installation .....	23
<b>5.</b>	<b>CONNECTION</b> .....	<b>26</b>
5.1.	Power supply.....	26
	Installation.....	26
5.1.1.	Connecting the power supply.....	27

<b>5.2. Data connections.....</b>	<b>28</b>
5.2.1. Block diagram.....	28
5.2.2. Ethernet interface (X3) .....	29
5.2.3. USB .....	30
<b>6. OPERATION .....</b>	<b>31</b>
<b>6.1. Switching on and off .....</b>	<b>31</b>
Switching on .....	31
Switching off .....	31
<b>6.2. Initial startup network .....</b>	<b>32</b>
6.2.1. VNC client configuration .....	32
6.2.2. Web terminal configuration .....	35
6.2.3. Configuration via the web interface .....	36
6.2.4. Web interface: Configuration .....	38
6.2.4.1 "Network" menu item .....	38
6.2.4.2 "Time and Date" menu item.....	39
6.2.4.3 "Display" menu item .....	39
6.2.4.4 "VNC Client" menu item .....	40
6.2.4.5 Menu item "SSH Server" .....	40
6.2.4.6 "Modbus Server" menu item.....	40
6.2.4.7 Menu item "Web server" .....	40
6.2.4.8 "Users" menu item.....	41
6.2.4.9 "Operating Mode" menu item .....	41
6.2.4.10 "Web browser" menu item .....	41
6.2.4.11 "Config protection" menu item .....	42
6.2.5. Web interface: System .....	43
6.2.5.1 Menu item "Info" .....	43
6.2.5.2 "Update" menu item.....	43
6.2.5.3 "Reboot" menu item.....	44
6.2.6. Web interface: Diagnostics .....	45
6.2.6.1 "System Log" menu item .....	45
6.2.6.2 "Ethernet" menu item.....	45
6.2.6.3 "Storage" menu item.....	45
6.2.6.4 "System Dump" menu item.....	45
<b>6.3. Operation.....</b>	<b>46</b>
6.3.1. Status indicators .....	46
6.3.2. Real-time clock with voltage buffer .....	47
Set date/clock.....	47
6.3.3. Function button S1 .....	48
Maintenance mode.....	48
<b>6.4. Troubleshooting .....</b>	<b>49</b>
6.4.1. No network connection .....	49
6.4.2. IP address unknown .....	49
<b>7. MAINTENANCE / SERVICING .....</b>	<b>50</b>
<b>7.1. Maintenance.....</b>	<b>50</b>
<b>7.2. Cleaning .....</b>	<b>50</b>
<b>8. DISASSEMBLY .....</b>	<b>51</b>

<b>9.</b>	<b>DISPOSAL</b> .....	<b>54</b>
<b>10.</b>	<b>INFORMATION AND OPTIONS</b> .....	<b>55</b>
<b>10.1.</b>	<b>Nameplate</b> .....	<b>58</b>
<b>10.2.</b>	<b>Device variants and identification</b> .....	<b>59</b>
<b>10.3.</b>	<b>Options and extensions</b> .....	<b>60</b>
<b>11.</b>	<b>STANDARDS AND CERTIFICATES</b> .....	<b>61</b>
<b>11.1.</b>	<b>Standards</b> .....	<b>61</b>
	Applied EU directives.....	61
	Applied EU standards .....	61
	Applied UKCA directives .....	61
	Applied UKCA- Standards .....	61
<b>11.2.</b>	<b>Declaration of conformity</b> .....	<b>62</b>
<b>12.</b>	<b>CUSTOMER SERVICE / ADDRESSES</b> .....	<b>63</b>
<b>12.1.</b>	<b>Customer service</b> .....	<b>63</b>
<b>12.2.</b>	<b>Repair Service</b> .....	<b>63</b>
<b>12.3.</b>	<b>Addresses</b> .....	<b>64</b>
<b>13.</b>	<b>APPENDIX</b> .....	<b>65</b>
<b>13.1.</b>	<b>Information on copyright and software license</b> .....	<b>65</b>
<b>13.2.</b>	<b>List of figures</b> .....	<b>65</b>

# 1. General information

Please read this user manual carefully before starting operation. Failure to do so may result in damage to the device and injury to operating personnel.

Safety-related information and its classifications are explained in the section “Hazard categories and signal words” (see 1.3). These instructions must be observed in all cases!

## 1.1. Notes on the manual

This manual is part of the product and applies to the following devices:

- B-Primis ET-Pi Prime 7
- B-Primis ET-Pi Prime 10
- B-Primis ET-Pi Prime 15

## 1.2. Symbols and illustrations sm

The following symbols and presentation methods are used in this user manual:

Symbol	Meaning
→ ...	List entry
▶ ...	Individual instruction or list of instructions that can be executed in any order.
1. ... 2. ...	List of instructions that must be carried out in the specified order.
	Further information about the product

Structure of the warning notices:

## 1.3. Hazard categories and signal words

The signal words described below are used for warnings that you must observe for your personal safety and to avoid damage to property.

The signal words have the following meanings:

### **DANGER**

#### **Serious injury or death**

Failure to observe the safety measures will result in death or serious injury.

- ▶ Observe the measures for prevention.

### **WARNING**

#### **Potential for serious injury or death**

Failure to observe the safety measures may result in death or serious injury.

- ▶ Observe the precautions.

### **CAUTION**

#### **Possible minor injury**

Failure to observe safety measures may result in minor injury.

- ▶ Observe the measures for prevention.

## NOTE

### **Possible property damage**

Failure to observe safety measures may result in damage to property.

- ▶ Observe the measures for prevention.

## 1.4. Qualified personnel

Installation, commissioning, and maintenance of the device requires qualified personnel.

Qualified personnel as defined in this documentation and the safety instructions contained therein are trained specialists who are familiar with the safety concepts of automation technology and who are authorized to assemble, install, commission, ground, and label devices, systems, and electrical circuits in accordance with safety engineering standards.

## 1.5. Duty of care

### 1.5.1. General

The operator or further processor (OEM) must ensure the following:

- The device is only used for its intended purpose.
- The device is only operated in perfect, functional condition.
- The user manual is always legible and available in its entirety.
- Only sufficiently qualified and authorized specialists carry out assembly, installation, commissioning, and maintenance of the device.
- These specialists are regularly instructed in all relevant aspects of occupational safety and environmental protection, and they are familiar with the contents of the user manual, in particular the safety instructions contained therein.
- The device markings and identifications as well as safety and warning notices affixed to the device are not removed and are always kept in a legible condition.
- The national and international regulations for the control of machines and systems applicable at the respective place of use of the device are observed.
- Users must always have access to all current information relevant to their needs regarding the device and its application and operation.
- The user is responsible for coordinating the use of safety-related control components with the relevant authorities and complying with their specifications.

## 1.6. Intended use

The device is part of a modular automation system for industrial control applications in the medium to high performance range.

It expands the automation system with a display and input system.

The device is designed for use in systems of overvoltage category I (IEC 60364-4-44) for the control and regulation of machines and industrial processes in low-voltage installations with the following conditions:

- Maximum rated supply voltage, 1000 V AC (50/60 Hz) or 1500 V DC
- Environment with maximum pollution degree 2 (EN 61010-1)
- Altitude up to 2000 m above sea level
- Only indoors without direct UV radiation
- Max. ambient temperature according to the technical specifications (see "Technical Data," p.54 )

Proper and safe operation of the device requires qualified project planning, proper transport, storage, installation, and use, as well as careful maintenance.

The device may only be used within the scope of the data and applications specified in this documentation and the associated user manuals.

Only use the device as follows:

- For its intended purpose
  - In technically perfect condition
  - Without unauthorized modifications
  - Exclusively by qualified users
- 
- ▶ Observe the regulations of the employers' liability insurance associations, the Technical Inspection Association, the VDE regulations, or corresponding national regulations.
  - ▶ The device is intended for installation in a suitable mounting cutout on industrial machines and systems indoors.
  - ▶ When installing, ensure that the existing sealing profiles are undamaged.
  - ▶ Observe the environmental conditions applicable to operation (see "Technical Data," p.54 )



The device is optionally available with UL certification.

This complies with UL Enclosure Type 1. Suitable installation must be ensured.

## 1.7. Transport and storage

The device is sensitive to shocks, strong vibrations, moisture, and extreme temperatures.

### Transport and storage

- ▶ Protect the device from heavy mechanical stress during transport.
- ▶ Always transport the device in its original packaging.
- ▶ Observe the environmental conditions applicable to storage (see "Technical Data," p.54 ).
- ▶ Protect the device from precipitation and moisture.

### Operation

- ▶ After storage or transport, only start up the device once it has reached the permissible operating conditions.
- ▶ After condensation, wait at least 12 hours before putting the device into operation .

## 1.8. Unpacking

Upon receipt of the delivery, ensure that the device is undamaged and complete.

- ▶ Check the packaging for external damage.
- ▶ If the packaging is severely damaged or if damage to the contents is apparent: Do not open the packaging further and inform the carrier and your supplier immediately.
- ▶ Remove the packaging and keep it for return transport.
- ▶ Check the contents for visible transport damage.
- ▶ Check the contents against the order for completeness and be sure to keep all documentation supplied. The documentation supplied contains important information about the device and is part of the product.
- ▶ If you notice any transport damage or discrepancies between the order and the delivered contents: Inform the supplier immediately.

## 2. Safety

### 2.1. Safety-related systems

The use of the device in safety-related systems requires special measures. If the device is to be used in a safety-related system, the user must seek detailed advice from the manufacturer in addition to any available standards or guidelines for safety-related installations.

- ▶ Before working on the devices, switch off all power supplies, including those of connected peripherals.
- ▶ Keep all ventilation openings clear.

In an electronic control system, the failure of certain components can lead to unregulated and/or unpredictable operation.

- ▶ Consider all types of failure at the system level and the associated safeguards.
- ▶ If necessary, consult the manufacturer of the automation system.

### 2.2. Safety instructions

#### CAUTION

##### **Minor injuries and burns to the skin surface**

Failure to observe the safety measures may result in minor injuries/burns to the skin surface!

The device may only be operated in perfect condition. Visible sharp edges or broken glass pose a risk of injury.

- ▶ If you notice damage to the front glass of the device, do not continue to operate the device and disconnect it from the power supply immediately.

The device housing can become very hot, especially at elevated ambient temperatures, due to the passive cooling of the internal components. The surface temperature may exceed the burn threshold depending on the duration of contact.

- ▶ Avoid touching the rear panel of the device during operation if possible.
- ▶ If you plan to work on the device, such as installing or removing it from the control cabinet or connecting or disconnecting a cable, switch off the device and allow it to cool down for a while.
- ▶ It is recommended to wear personal protective equipment such as gloves when handling the heated device.

**Working on the device**

Work may only be carried out on the device once all necessary safety measures have been taken. Unpredictable functions and movements of the system must be avoided.

- ▶ Bring the system to a safe state.
- ▶ Switch off the system and the device.
- ▶ Secure the system against being switched back on.
- ▶ Disconnect the device from the system.

The housing of the device must not be opened!

- ▶ If work is required inside the device or you suspect a defect, contact the manufacturer (see "Addresses").

## 2.3. Cyber security

- ▶ Never connect the device to the Internet without additional protective mechanisms; this product is not designed for this purpose.
- ▶ Change the default passwords specified on delivery.
- ▶ Always use an upstream external firewall to prevent external access to the internal network.
- ▶ Always use https instead of http.
- ▶ Deactivate all unnecessary services (e.g., FTP/SSH/web server).

Contact for cyber security of Berghof products:

**Berghof Product Security Incident Response Team**

[psirt.automation@berghof.com](mailto:psirt.automation@berghof.com)

### **3. Product description**

The devices in the B-Primis ET-Pi Prime family are high-quality input devices with displays for connection to a control system for machines or systems. These devices display the CODESYS web visualization or CODESYS target visualization, regardless of whether the source of the visualization is a Berghof PLC controller or another CODESYS controller.

The connection level of the devices for all external connections is located on the underside. These devices are intended for installation in a prepared mounting cutout in a flat surface. All connections are pluggable.

### 3.1. Overview ET-Pi Prime 7/10/15

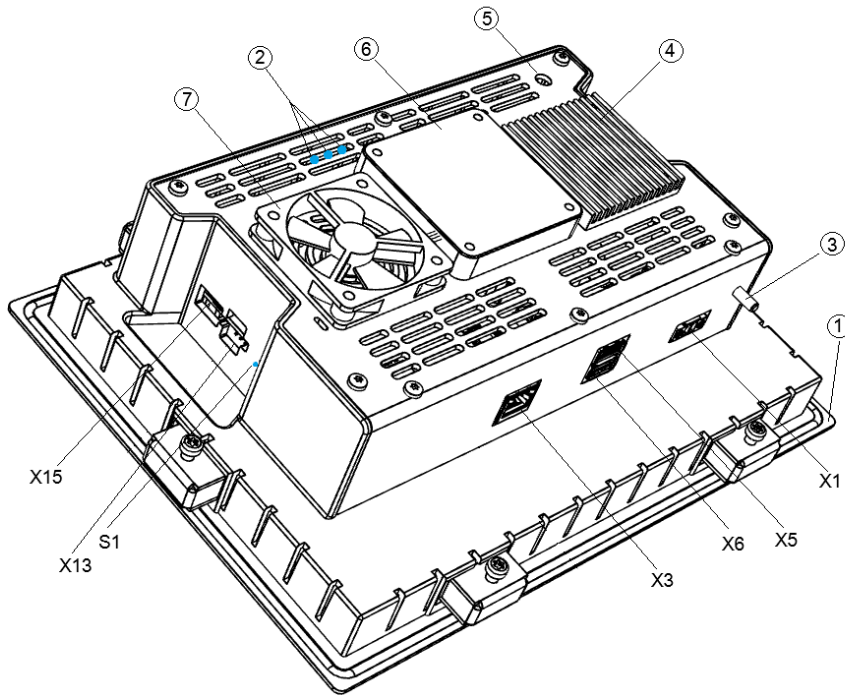

1 : Overview of B-Primis ET-Pi Prime 7/10/15 (rear view)

Item	Designation	Item	Description
1	Display	X3	Ethernet (ETH0)
2	LEDs: Power, Run/Stop, Error	X5	USB host
3	Ground connection	X6	USB host
4	Cooler (optional)	X13	Debug interface (do not use - for Berghof service technicians only)
6	VESA mount (optional)	X15	USB device (do not use – for Berghof service personnel only)
7	Fan (optional)	S	Function key Maintenance Mode
X	Power supply		

## 3.2. Scope of delivery and accessories

### Scope of delivery

- B-Primis ET-Pi Prime
- 2-pin power supply connector
- Securing clips:
  - ET-Pi Prime 7"/10": 6 pieces
  - ET-Pi Prime 15: 10 pieces

### Accessories

The following accessories can be ordered via the device options (for further information, see chapter 10.3):

- Securing clip, order no. S-02060201-0100

## 3.3. Product features

### Performance features at a glance

- Raspberry PI CM4 (1.5 GHz quad core)
- Data storage (RAM): 1 GB to 8 GB RAM
- Program memory (flash): 8 GB to 32 GB eMMC flash
- 1 Ethernet 10/100/1000 Base-T interface
- 2 USB host interfaces
- Real-time clock

### Mounting

The device is designed for installation in a front panel or control cabinet in an industrial environment.

### Processor

The basic configuration of the device includes a Raspberry Pi Compute Module 4 (1.5 GHz Broadcom BCM2711, Quad Core Cortex-A72 (ARM v8) 64-bit SoC)

### Ethernet

An Ethernet interface with 10/100/1000 Mbit/s is available. The TCP/IP and UDP/IP protocols enable a very flexible connection to visualization software, higher-level control units, or the IT infrastructure.

### USB

The USB 2.0 host interface provides a widely used peripheral interface. This allows expansion with compatible USB devices (keyboard, mouse).



For support of other USB devices, please contact our technical support team.

### Real-time clock

A capacitor-buffered, maintenance-free real-time clock can be set to the current time via a software interface. The buffer time is 30 days.

## 4. Installation

### 4.1. Installation preparation Front installation ET-Pi Prime 7

The device is designed for front installation in a rectangular mounting cutout. The mounting material must be dimensionally stable and have a thickness of 1 to 3 mm.

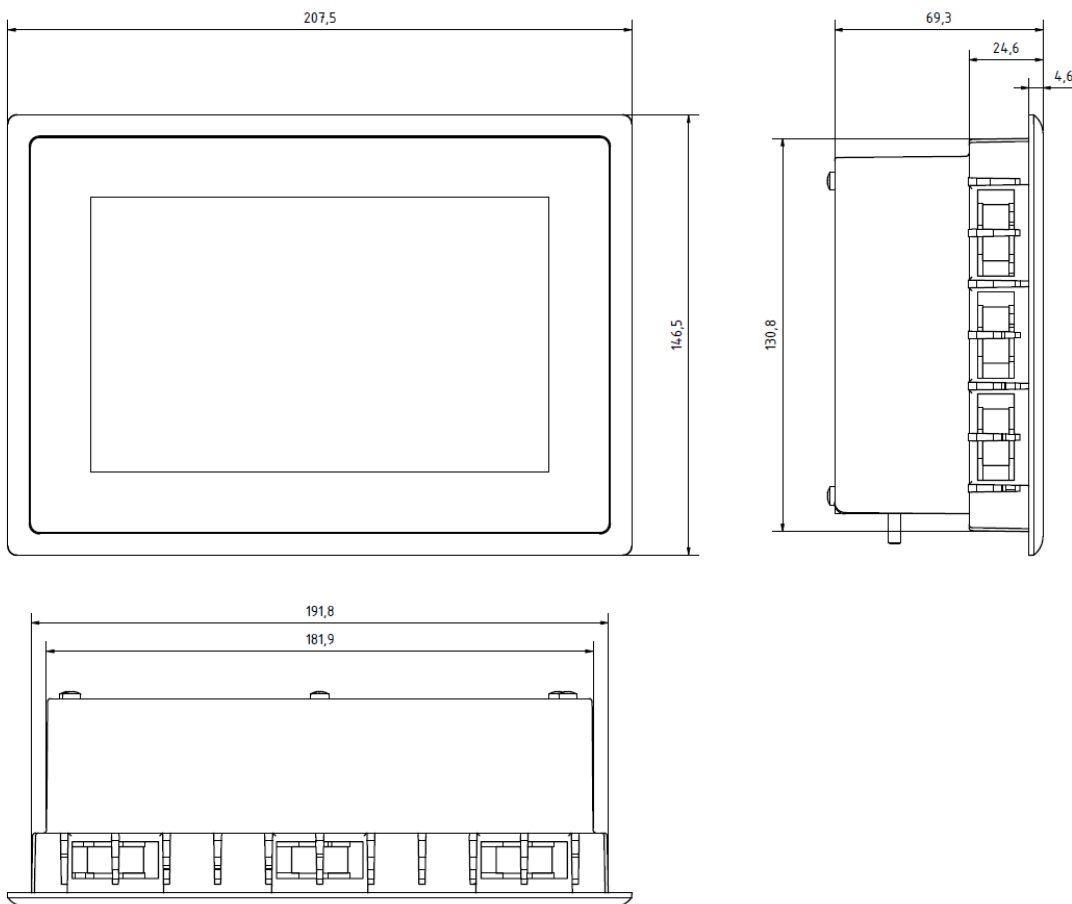

Fig.2 : Dimensions ET-Pi Prime 7

#### Requirements:

- The device must have at least 20 mm of free space around the rear of the installation site to ensure sufficient air circulation.
- The substrate for the mounting cutout must be sufficiently thick, level, and stable.

## NOTE

### Damage to the device!

Installation on an uneven surface can lead to mechanical stress and cracks in the front panel or to incorrect operation of the touch surface.

- ▶ Ensure that all contact points of the device are on the same level and deviate from each other by no more than  $\pm 0.5$  mm.



Fig.3 : Installation cutout ET-Pi Prime 7

- ▶ Cut a rectangular mounting cutout from the substrate material:  
 Height: 132.5 mm  
 Width: 193 mm  
 Max. corner radius: 1.5 mm



Optimal thickness of the substrate: 1.0 to 3.0 mm

## 4.2. Installation preparation for front installation ET-Pi Prime 10

The device is designed for front installation in a rectangular mounting cutout. The substrate must be dimensionally stable and have a thickness of 1 to 3 mm.

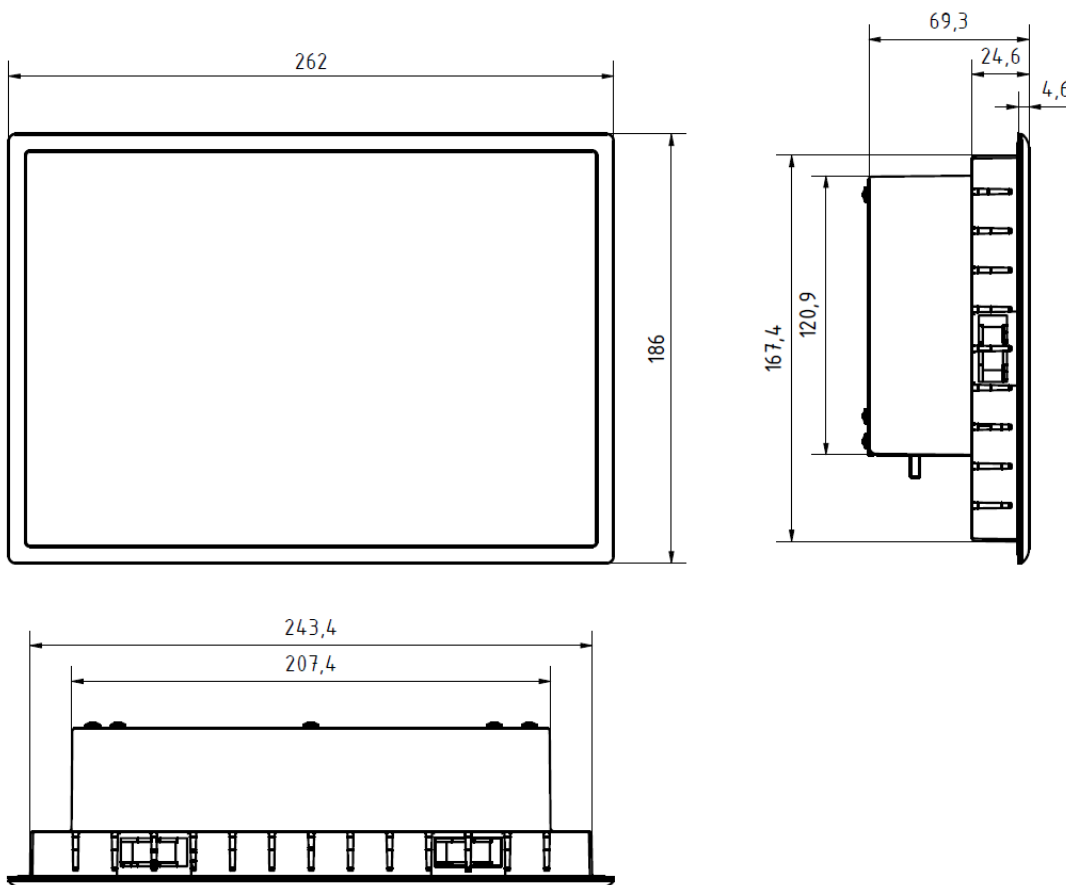

Fig.4 : Dimensions ET-Pi Prime 10

### Requirements:

- The device must have at least 20 mm of free space around the rear of the installation site to ensure sufficient air circulation.
- The substrate for the mounting cutout must be sufficiently thick, level, and stable.

## NOTE

### Damage to the device!

Installation on an uneven surface can lead to mechanical stress and cracks in the front panel or to incorrect operation of the touch surface.

- ▶ Ensure that all contact points of the device are on the same level and deviate from each other by no more than  $\pm 0.5$  mm.

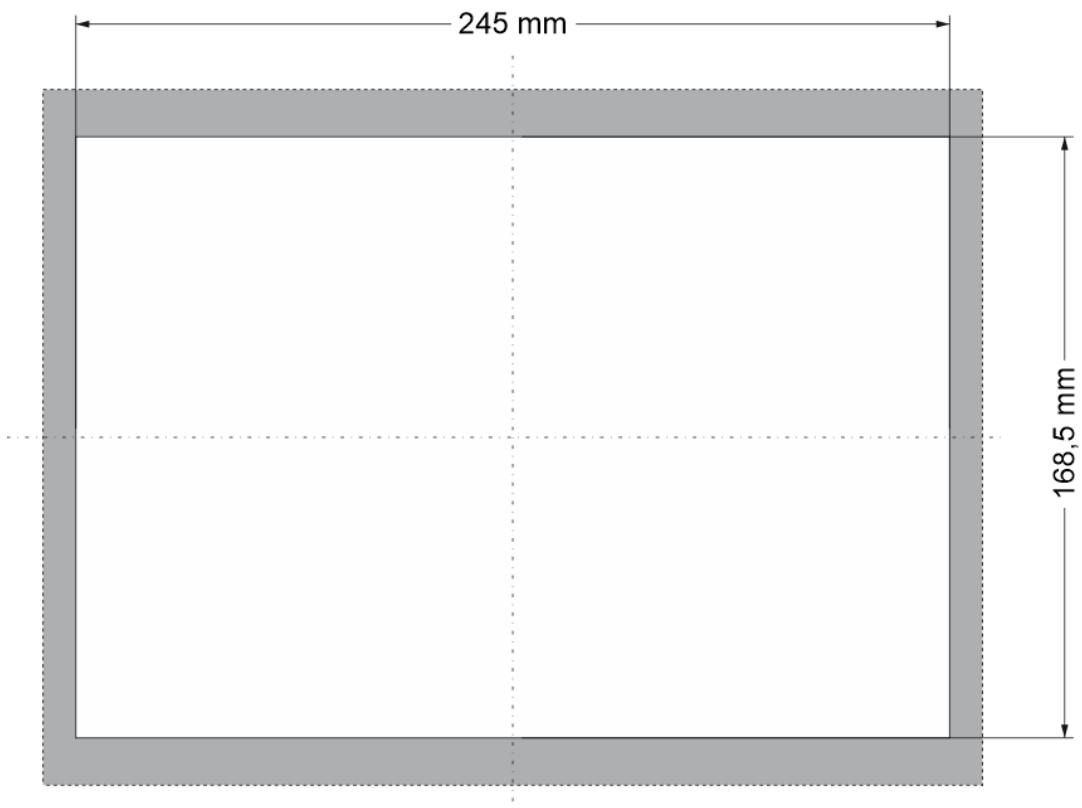

5 : Mounting cutout ET-Pi Prime 10

- ▶ Cut a rectangular mounting cutout from the mounting material:  
 Height: 168.5 mm  
 Width: 245 mm  
 Max. corner radius: 1.5 mm



Optimal thickness of the substrate: 1.0 to 3.0 mm

### 4.3. Installation preparation Front installation ET-Pi Prime 15

The device is designed for front installation in a rectangular mounting cutout. The substrate must be dimensionally stable and have a thickness of 1 to 3 mm.

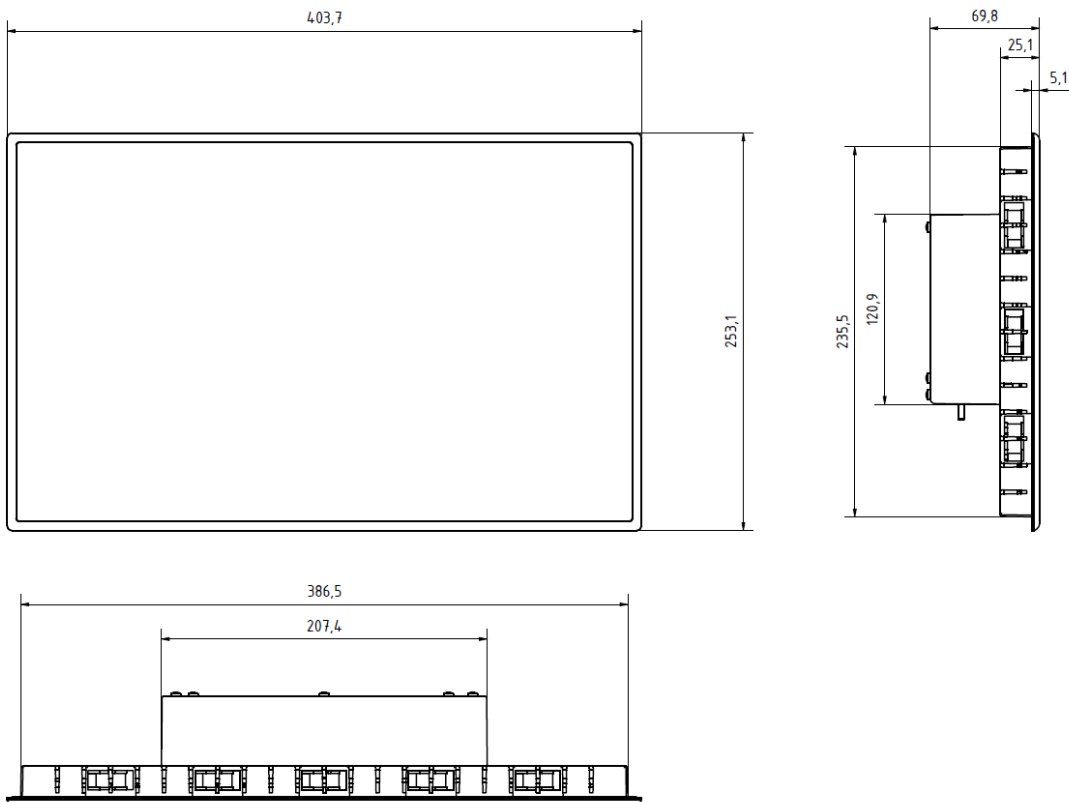

Fig.6 : Dimensions ET-Pi Prime 15

#### Requirements:

- The device must have at least 20 mm of free space around the back at the installation site to ensure sufficient air circulation.
- The substrate for the mounting cutout must be sufficiently thick, level, and stable.

#### NOTE

##### Damage to the device!

Installation on an uneven surface can lead to mechanical stress and cracks in the front panel or to incorrect operation of the touch surface.

- ▶ Ensure that all contact points of the device are on the same level and deviate from each other by no more than  $\pm 0.5$  mm.

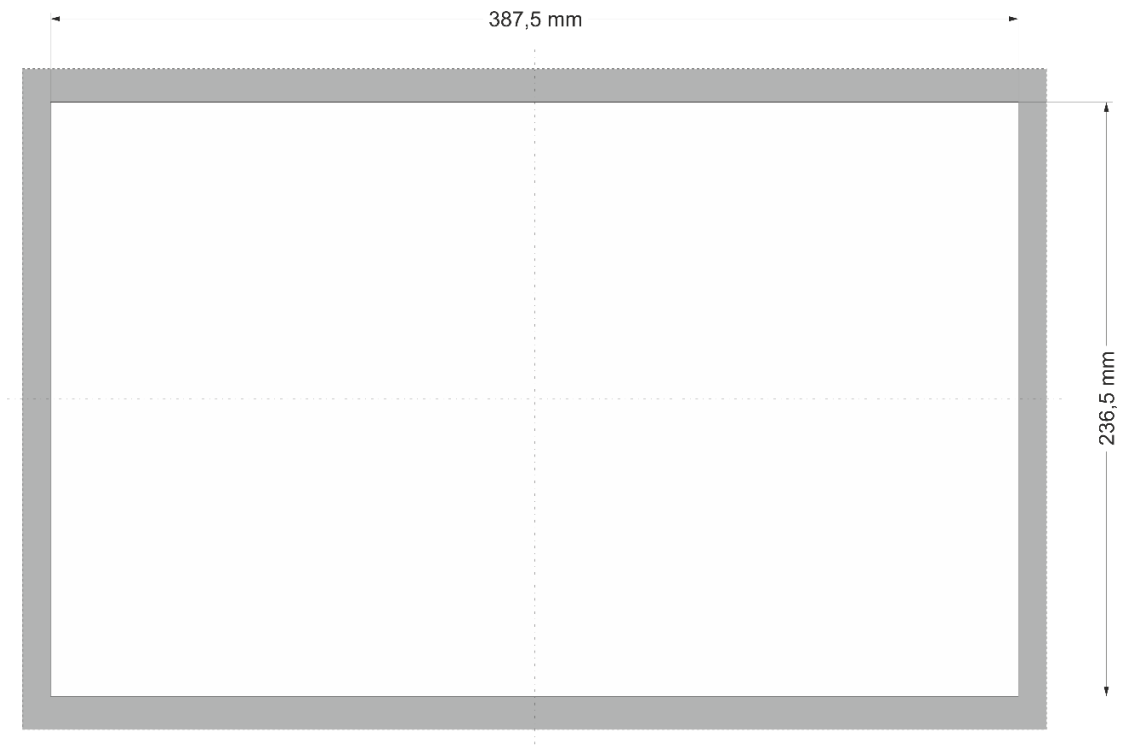

Fig.7 : Mounting cutout ET-Pi Prime 15

- ▶ Cut a rectangular mounting cutout from the mounting material:  
Height: 236.5 mm  
Width: 38 7.5 mm  
Max. corner radius: 1.5 mm



Optimal thickness of the substrate: 1.0 to 3.0 mm

## 4.4. Installation

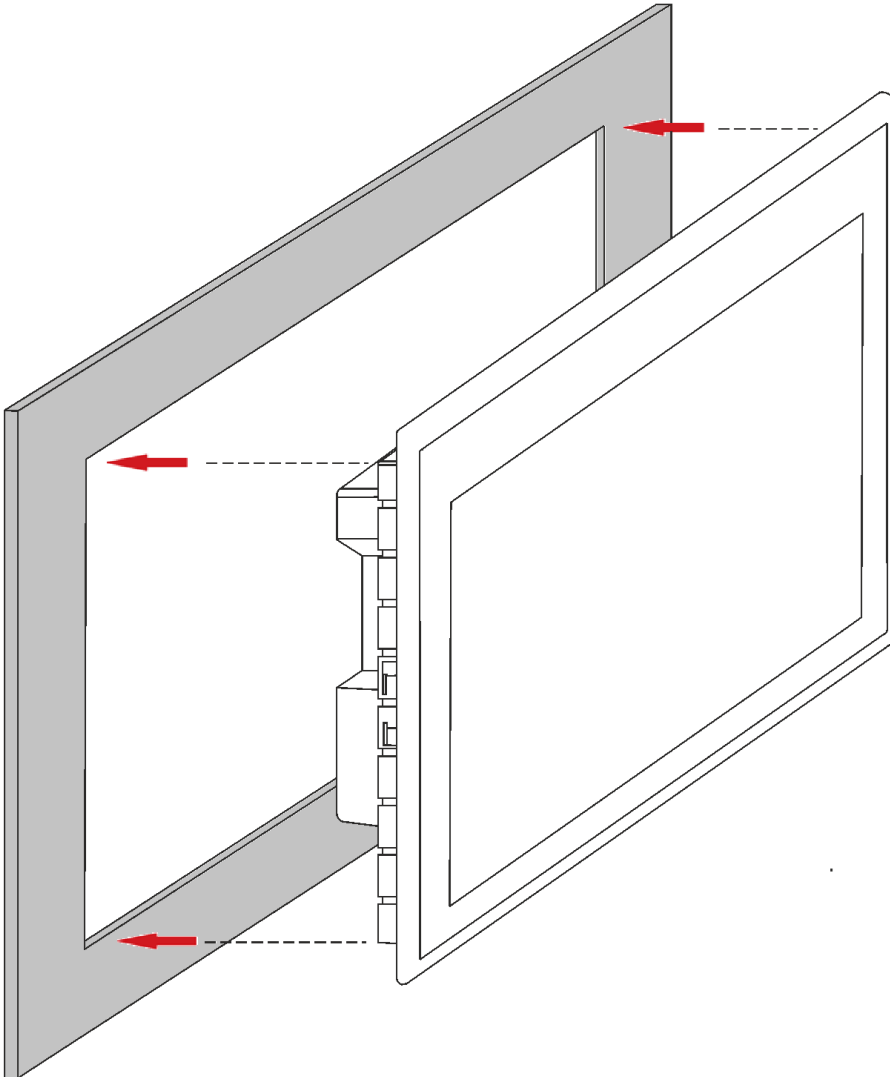

Fig.8 : Insertion into mounting cutout

### Requirements:

→ The securing clips must not be attached to the device.

1st Observe the alignment and press the device evenly into the mounting cutout.

## NOTE

### Damage to the device!

The device may fall out of the mounting cutout or be damaged if installed carelessly.

- ▶ Do not tilt the device.
- ▶ Secure the device against falling until the clamps are fastened.

2nd Ensure that the device fits snugly all around.

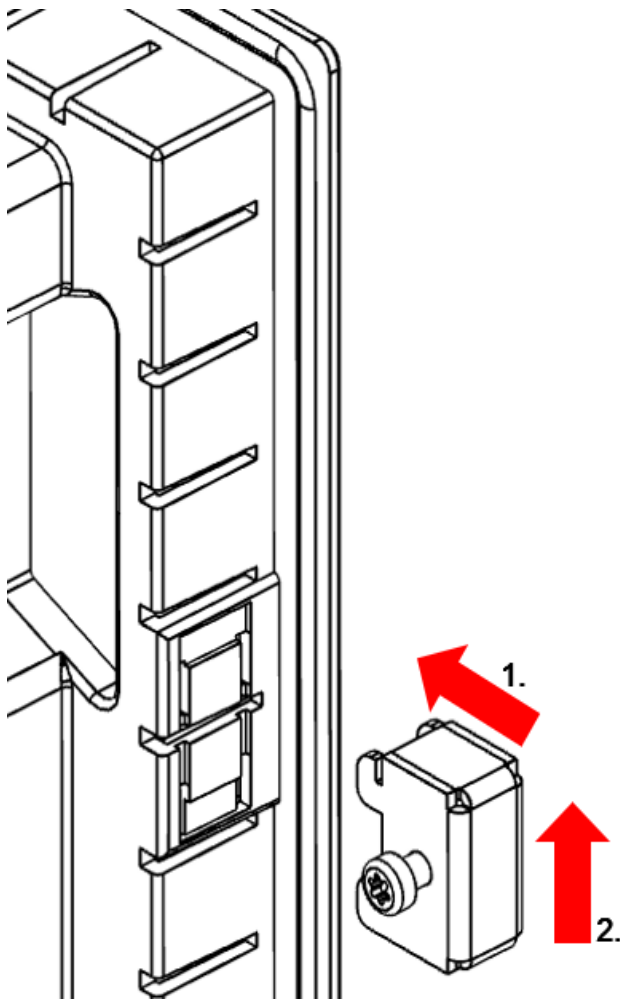
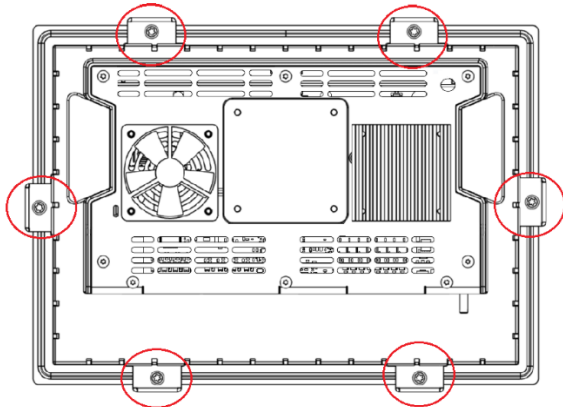
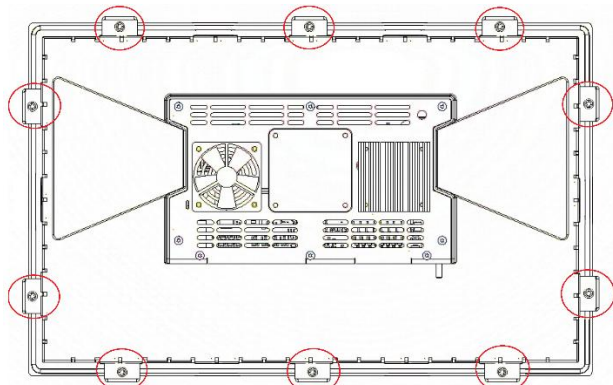

Fig. 9 : Mounting the securing clips

3rd Secure the device with 2 securing clips: Hook the securing clips diagonally opposite into the cover and tighten the screws slightly.



B-Primis ET-Pi Prime 7 / 10



B-Primis ET-Pi Prime 15

IP54: 10 securing clips,  
standard features

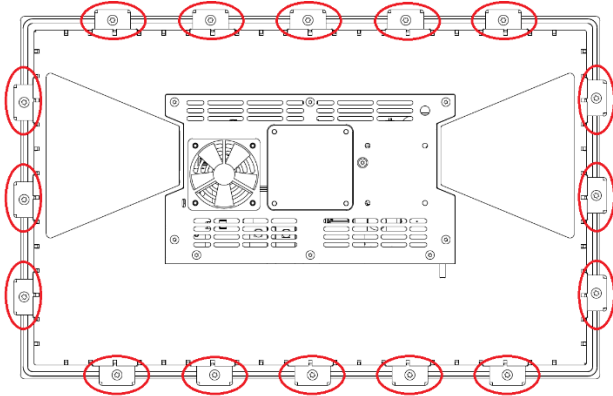

IP65: 16 securing clips,  
expansion pack required:  
order no. S-02060201-0100

Fig. 10 : Fully tightening the securing clips

4. Attach the remaining clamps and tighten the screws on all clamps evenly (max. 0.4 Nm).  
 ET-Pi Prime 7" / 10": 6x securing clip  
 ET-Pi Prime 15": 10x securing clip for IP54 / 16x securing clip for IP65

## 5. Connection

### WARNING

#### Unregulated, unpredictable operation!

Failure of certain components in electronic control systems can lead to unregulated and unpredictable operation.

- ▶ Take into account all types of failure at the system level and the associated safety measures.
- ▶ Observe the specifications of the automation system manufacturer.

### 5.1. Power supply

The device is powered by an external 24 V DC power supply.

- ▶ Before connecting, check that the specifications required for the external power supply are met (type K according to DIN EN 61131-2).

#### External power supply (24 V DC)

Supply voltage	+24 V DC SELV (-15% / +20%)
AC voltage component	Max. 5 The DC voltage level must not fall below 20.4 V.
Power consumption	ET-Pi Prime 7: Total max. 0.25 A at +24 V DC ET-Pi Prime 10: Total max. 0.55 A at +24 V DC ET-Pi Prime 15: Total max. 1.2 A at +24 V DC

#### Installation

- ▶ All connections and cables must be routed in such a way that no interference is caused by inductive and capacitive interference on the device.
- ▶ Ensure that the supply cables have sufficient current and voltage resistance.

### 5.1.1. Connecting the power supply

#### **⚠ CAUTION**

##### Live parts!

- ▶ Before working on the device, switch off all power supplies, including those of connected peripherals.

##### ET-Pi Prime

- ▶ Connect the power supply to connector X1 according to the following table.

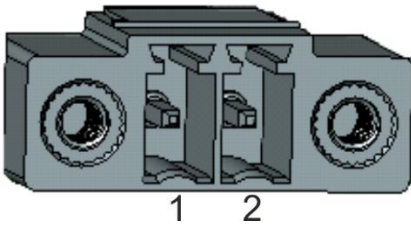

Fig. 11: Power supply X1

#### Power supply connector X1

Pin	Ref.	Assignment
1	L0+ 24 V	24 V DC power supply (-20%/+25%)
2	L0-	GND 0 V DC

The following counterparts have been tested for the 15EDGRM-THR-3.5-02P-13-10Z (DEGSON) series connector and may be used with the device:

- **15EDGKNM-3.5-02P-13-1000Z (DEGSON)**

## 5.2. Data connections

### 5.2.1. Block diagram

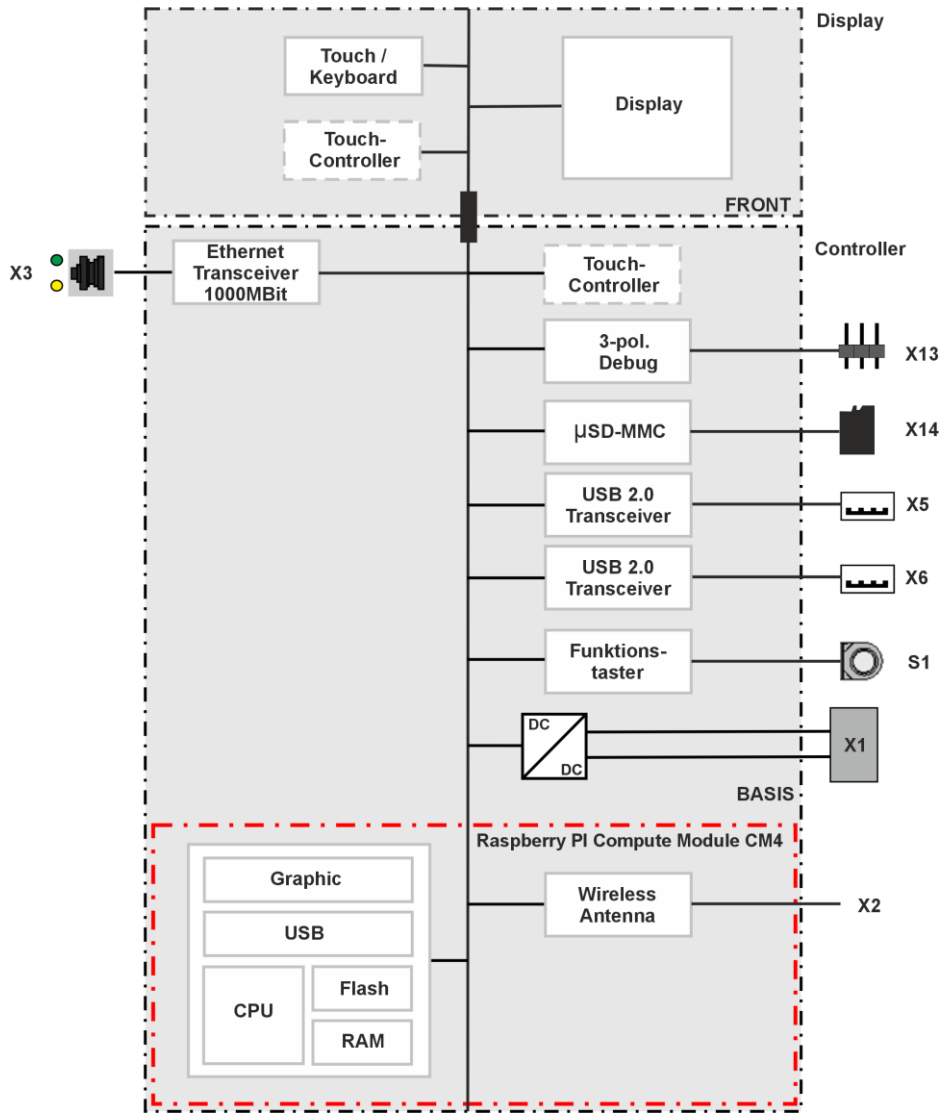

Fig. 12: Block diagram ET-Pi Prime

### 5.2.2. Ethernet interface (X3)

The onboard Ethernet adapter has a 1000/100/10 Base-T with RJ-45 connectors for the X3 network connection.

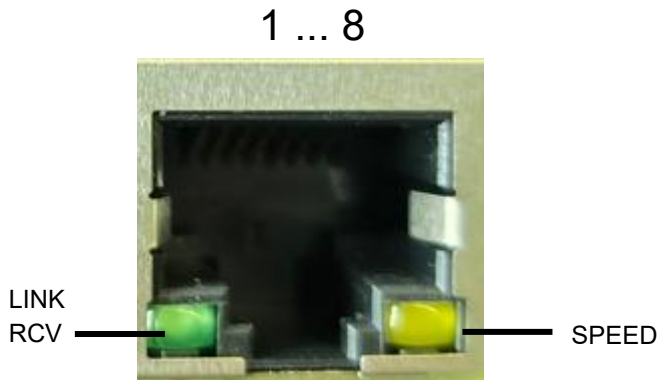

Fig. 13: Ethernet interface X3

Assignment of Ethernet interface connector X3			
Pin	Assignment	Pin	Assignment
1	BI_DA+ Bi-directional pair A+	5	BI_DB- Bi-directional pair B-
2	BI_DA- Bi-directional pair A-	6	BI_DC- Bi-directional pair C-
3	BI_DB+ Bi-directional pair B+	7	BI_DD+ Bi-directional pair D+
4	BI_DC+ Bi-directional pair C+	8	BI_DD- Bi-directional pair D-

LEDs		
LED	Color	Meaning according to IEEE 802.3 clause 25
LNK/RCV	Green	Link, data receive Flashing: Connection is active, data transfer in progress Off: No connection established
SPEED	Yellow	On = 1000 Mbit/s On = 100 Mbit/s Off = 10 Mbit/s

### 5.2.3. USB

Devices with a USB interface can be connected to the USB host port.

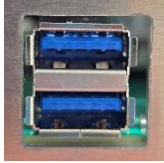

Fig.14 : USB interfaces X5 and X6

#### NOTE

##### **Damage to the USB stick and malfunctions due to data loss!**

Removing a USB stick during operation while file operations are still running can render the USB stick unusable. Open files that a program can no longer access when the USB stick is removed can block the device.

- ▶ Before removing the USB stick, make sure that all data operations have been completed.

#### NOTE

##### **Property damage and malfunctions due to data loss!**

The USB interface is protected against overload (see USB interfaces max. current → p.54 ). In the event of a short circuit during operation, a reset of the device may be triggered.

This can result in significant property damage and damage to the USB device.

- ▶ Check the power consumption of a USB device before use.

#### NOTE

##### **Failures and malfunctions may occur when connected directly to the signal ground!**

- ▶ Only use USB devices that do not have a direct connection between the signal ground and the housing.



The mechanical design of the USB interface is rated for up to 1000 mating cycles.

## 6. Operation

### 6.1. Switching on and off

#### NOTE

##### Damage or malfunction!

- ▶ Do not plug in, connect, disconnect, or touch any connections during operation.
- ▶ Before working on the device, switch off all power supplies, including those of connected peripherals (externally powered encoders, programming devices, etc.).

#### NOTE

##### Property damage!

- ▶ Before applying the supply voltage, check that all connections are correctly wired and that the polarity is correct.

##### Switching on

The device does not have its own power switch. The device is started when the system is switched on or when the power supply is connected.

##### Switching off

The device is switched off when the system is switched off or disconnected from its own power supply.

## 6.2. Initial startup network

### 6.2.1. VNC client configuration

The device must be connected to the network with the correct settings before it can be used.

#### NOTE

##### Property damage!

- ▶ Before applying the supply voltage, check that all connections are correctly wired and that the polarity is correct.

1. Supply the device with power (24 V).  
After startup, the current network settings are displayed (server IP, IP address, and network mask).

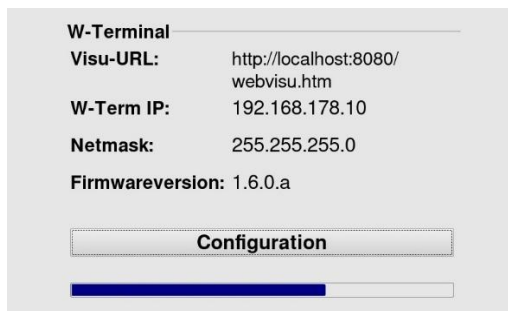

Fig. 15: Home page with network settings

2. Press "Configuration."  
A page with further information will appear.

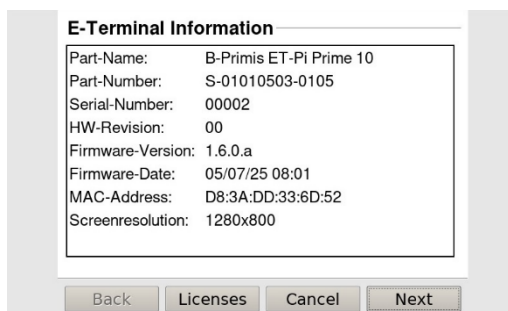

Fig. 16: Information page

- Press the "Next" button.  
The network mode of the device is displayed. Here you can choose between "Static" and "DHCP."

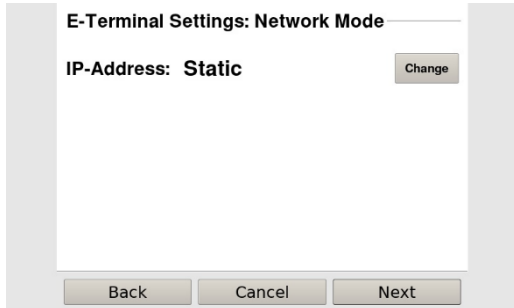

Fig. 17: Network mode of the device

- Press the "Next" button.  
The pages with the device's network settings are displayed.

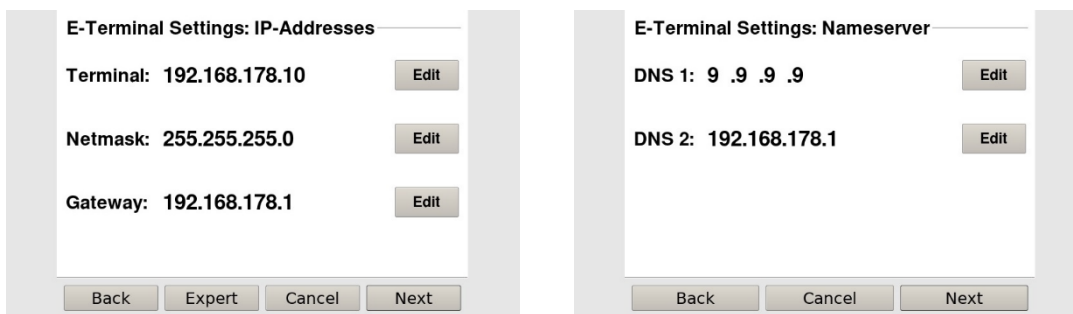

Fig. 18: Network settings of the device

If necessary, press the "Edit" button and change the network settings as desired (IP address, network mask, gateway, and name server). Only possible in "Static" mode.

- Press the "Next" button.  
The page with the settings for the Network Time Protocol (NTP) appears. These settings are optional.



Fig. 19: NTP settings of the device

6. Press the "Next" button.  
The page with the settings for the server IP and Lifeguard appears.

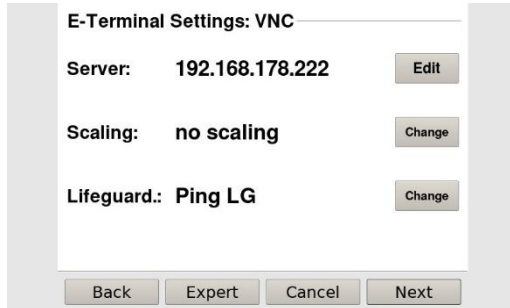

Fig. 20: Setting the server IP

7. If necessary, press the "Change" button and change the server IP as required.
8. Press the "Expert" button to change the "Lifeguard" setting.  
The page with the expert settings is displayed.  
- or -  
Press the "Next" button and proceed to the next page.

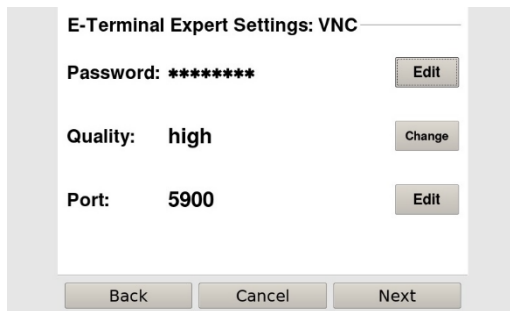

Fig. 21: Changing the Lifeguard setting

9. Depending on the controller version, press the "Change" button to change the Lifeguard setting:  
CODESYS V2: "BERGHOF VNC LG"  
CODESYS V3: "Ping LG"
10. Press the "Next" button to skip the following pages until the page with the summary of the network settings appears.

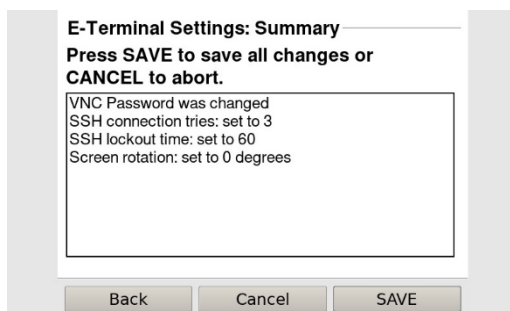

Fig. 22: Summary of network settings

11. If no settings have been changed, press the "OKAY" button.  
The main screen of the device will be displayed.  
- or -  
Press the "Save" button.  
The settings will be saved and the device will restart automatically.
12. Connect the device to the controller using the network cable.

The device is now configured and ready for use.

## 6.2.2. Web terminal configuration

Before the device can be used in web terminal mode, it must be connected to the network with the correct settings. Please refer to Chapter 6.2.3 Configuration.

1. Supply the device with power (24 V).
2. After startup, the current network settings are displayed (server IP, IP address, and network mask).
3. Press the "Configuration" button and then the "Next" button.
4. The page with the device's network settings is displayed.
5. Press the "Expert" button and then the "Change" button to convert the device into a web terminal.

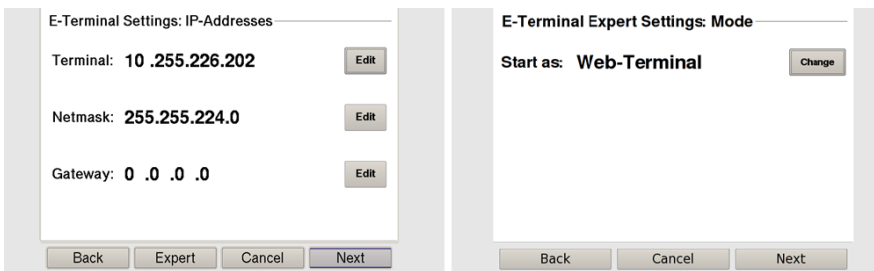

23 : Switching to web terminal mode

6. Press the "Next" button to skip the following pages until the page with the summary of the existing settings appears.
7. Press the "Save" button. The settings are saved and the device restarts automatically.

After restarting, the device will be in web terminal mode.



The "Configuration" button is only accessible for a short time after power-up. After a few seconds, the device starts its integrated browser and blocks the "Configuration" button.

Once this has happened, the "Configuration" button can only be accessed by restarting the device.

8. Press the "Configuration" button immediately after startup.
9. Press the "Next" button to skip the IP settings until the page with the Visu URL appears.
10. Press the "Change" button.
11. Enter the desired URL and confirm with the "OK" button.

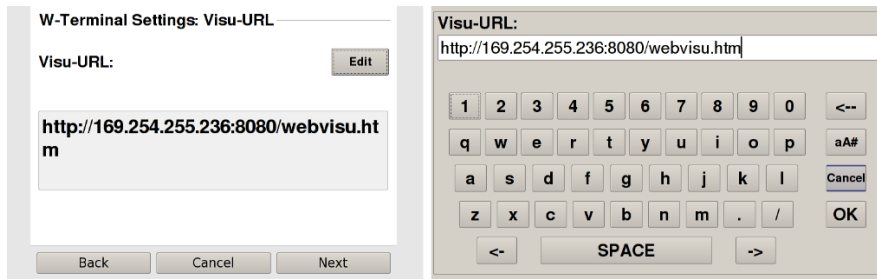

Fig. 24: Setting the Visu URL

12. Press the "Next" button to skip the following pages until the page with the summary of the existing settings appears.
13. Press the "Save" button.

The settings are saved and the device is automatically restarted.

After restarting, the device launches its integrated browser and automatically loads the configured URL setting for the visualization.

### 6.2.3. Configuration via the web interface

The device must be connected to the network with the correct settings before it can be used.

## NOTE

#### Property damage!

- ▶ Before applying the supply voltage, check that all connections are correctly wired and that the polarity is correct.

- 1st Supply power to the device (+24 V DC).  
After startup, the current IP address and netmask of the device are shown at the bottom right of the display.
- 2nd Connect the device to a programming computer via a network cable (X3) and network switch.
- 3rd Open the web browser on the programming computer.
- 4th `https://` Enter the IP address of the device in the web browser.

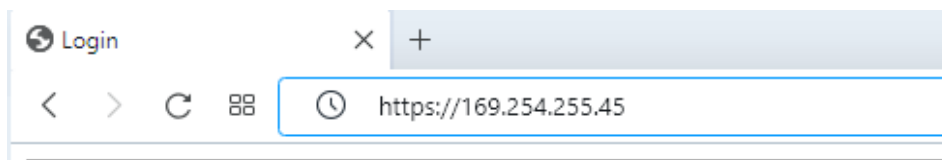

Depending on the browser used, a warning about an unknown connection may be displayed. This connection must be manually trusted in the browser.

The login window appears.



### User Login:

Name:

Password:

Fig. 25: Login window

2nd Name: admin

The default password printed on the device label is used as the password.

## 6.2.4. Web interface: Configuration

### 6.2.4.1 "Network" menu item

Various network settings for the device can be configured on this page.

#### **i** NOTE

- ▶ The network settings are always activated after restarting the device.

#### **Host**

The hostname is a unique name for the device. The hostname is used as **the device name**. Hostnames consist of one or more labels separated by a period. A label consists of one or more characters.

Labels can be up to 24 characters long and may only consist of ASCII characters:

- a-z or A-Z (upper and lower case letters are not distinguished),
- numbers 0-9
- hyphen / minus sign -

Other characters are not permitted according to RFC952 and may cause problems. The host name can also be a fully qualified domain name (FQDN), such as *plc24.mycompany.de*.

#### **i** NOTE

- ▶ Please note that no DNS or WINS services are running on the device, so the device cannot be addressed via the host name without additional configuration (e.g., entry in the network's DNS server).

#### **DNS server**

If the device is to have access to the Domain Name System (DNS), i.e. if other hosts are to be addressed by their name instead of their IP address, at least one valid DNS server must be entered here. The second DNS server serves as a fallback if the first server is not available. If no DNS is to be used, both entries can be set to 0.0.0.0 (default setting).

#### **ETH0**

In Linux, eth0 is the device name of the device's network interface. The interfaces can be freely configured. In the default state, the network interface eth0 is configured with a static IP address (mode: static).

#### **Network mode: inactive**

In this mode, the network interface is completely disabled.

#### **Network mode: static**

In this mode, a static IP address can be configured. The static IP address and the netmask (also called NetMask or subnet mask) are required.

#### **Network mode: dhcp**

In this mode, the network interface can be automatically assigned an IP address from a DHCP server when the device is started. The IP address and netmask fields can be set to 0.0.0.0 (default setting).

#### 6.2.4.2 "Time and Date" menu item

On this page, you can set the time for the device's real-time clock (RTC) and specify time zones. By default, the time zone for Berghof devices is set to Coordinated Universal Time (UTC). The special feature of this setting is that the UTC time zone is the RTC of the controller. Changing the UTC time value also changes the RTC. Upon delivery, the RTC of the controller is set to the current German time.

It is also possible to set the system time via the Network Time Protocol (NTP).

It is possible to define up to three NTP servers.

If this option is enabled, the device searches for an NTP server at the configured IP address when it boots up and synchronizes the time. After the initial synchronization, the PLC updates the time once every 24 hours.

#### 6.2.4.3 "Display" menu item

Various settings relating to the display can be changed on this page.

Setting	Description
<b>Brightness level</b>	The brightness of the display can be adjusted in eight different levels.
<b>Screen rotation</b>	Rotate the displayed image counterclockwise to the set degrees.
<b>Touch calibration</b>	The previous calibration data for the touchscreen can be deleted.
<b>Show cursor timeout</b>	Timeout in seconds until the mouse pointer becomes invisible
<b>Screensaver timeout</b>	Timeout until the screensaver is activated on the display interface
<b>Splash screen</b>	An image in PNG format can be uploaded, which is displayed on the screen when the controller is started.

#### 6.2.4.4 "VNC Client" menu item

On this page, you can configure the connection settings to a VNC server when an e-terminal device is in VNC client mode.

Setting	Description
<b>VNC server</b>	IP address of the VNC server to which the ET should connect.
<b>Port</b>	Network port of the VNC server to which the ET should connect.
<b>Quality</b>	Image quality settings for the displayed VNC connection. Lower quality settings reduce bandwidth and the load on the ET.
<b>Screen scaling</b>	Option to reduce the resolution of the VNC server to match the ET. No scaling: displays the VNC server in native resolution Keep aspect ratio: scales the VNC server image down to the ET resolution and maintains the native aspect ratio Scale to screen: Scales the VNC server image to the ET resolution in full-screen mode, ignoring the original aspect ratio
<b>Lifeguarding</b>	Lifeguarding mode for checking the VNC server connection Ping LG: Standard lifeguarding via a network ping Berghof VNC LG: Legacy lifeguarding mode that can only be used with older Berghof CODESYS V2.3 controllers

It is also possible to set a password for a VNC server that has active password protection.

#### 6.2.4.5 Menu item "SSH Server"

On this page, the device's internal SSH server can be enabled or disabled.

In addition, it is possible to activate brute force detection and configure the connection attempts and the lockout time in seconds after the configured attempts have been reached.

Only the root user can access the controller via SSH.

#### 6.2.4.6 "Modbus Server" menu item

Activates an optional Modbus TCP server on ET devices, which enables remote control of screen brightness and signal tone via controllers that support Modbus TCP client.

The control values can be set via a Modbus TCP client - function code 16 (write multiple registers) with start address 0x0000 and length 4

0x0000 - Brightness of the screen in active mode - Valid values: 0 (off) - 9

0x0001 - Brightness of the screen in passive mode (screen saver) - Valid values: 0 (off) - 9

0x0002 - Timeout until the screen switches to passive mode, in seconds. - Valid values: 0 (off) - 7200

0x0003 - Volume of the integrated beeper - Valid values 0 (off) - 4

It is also possible to read the set values via a Modbus TCP client - function code 04 (read input registers) with start address 0x0000 and length 4; the settings are in the same order as when writing the values.

#### 6.2.4.7 Menu item "Web server"

The device's internal web interface can be enabled or disabled in the Settings submenu.

**⚠ CAUTION**

**If you deactivate the web interface, you will lose access to the configuration menu!**

- ▶ To regain access to the web interface after deactivation, you can use the maintenance mode.

Additional settings include changing the default ports for https.

**i NOTE**

- ▶ Unencrypted access to the web interface is not possible; requests to the web interface via http:// are not automatically redirected to https://.
- ▶ All controllers always have a (self-signed) default certificate that must be manually trusted when the web interface is first loaded by a browser.

In the Certificate (self-signed) submenu, the controller can create a self-signed certificate with various login details. The self-created certificate can be downloaded and imported into the browser used to display the web interface, or you can trust the certificate again the next time you call up the web interface.

On the Certificate (ext. CA) page, the controller can create a certificate request with various login details. You can then download this request and have it signed by an external certification authority (CA). Once you have received the externally signed certificate, you can upload it to the controller via the sub-item "Upload certificate to this device".

After restarting the controller and opening the web interface for the first time, the browser should then recognize the externally signed certificate itself and automatically trust it.

Each self-signed or externally signed certificate process must be performed with each device.

**6.2.4.8 "Users" menu item**

On this page, you can change the passwords of the users on the device.

Change the passwords of all users before using the controller in a productive environment, or ensure that no physical access to the controller or the network connected to the controller is possible.

User name	FTP/Web	FTP rights	Web rights
root	Yes / Yes	Read/Write	Read/Write
admin	No / Yes	None	Read/Write

**6.2.4.9 "Operating Mode" menu item**

On this page, the operating mode of the ET devices can be set to either E-Terminal (VNC client) or Web Terminal (web client).

**6.2.4.10 "Web browser" menu item**

The web browser menu consists of two submenus for "Settings" and "Certificates."

In the "Settings" submenu, you can specify a "Destination URL:" that will be loaded when the controller starts up.

Setting	Description
---------	-------------

<b>Browser decorated mode</b>	By default, the integrated web browser starts in kiosk mode without a browser GUI. With this option, the browser is loaded with its full user interface.
<b>URL connectivity check</b>	Enables a loading page that displays information while attempting to load the "Destination URL".
<b>Onscreen keyboard</b>	Enables the use of an automatic pop-up keyboard when using the ET in web mode.
<b>Browser remote debugging (expert setting)</b>	Expert setting, enables remote debugging with the browser development tools.
<b>Pinch-to-zoom (expert setting)</b>	Expert setting, activates the "pinch to zoom" gesture for zooming in and out.

The "Certificates" submenu shows an overview of all installed certificates used by the internal web browser; this certificate submenu is not related to the certificates for the web server. There are options for deleting selected certificates or the entire list, as well as an upload option for loading external certificates into the internal web browser.

#### **6.2.4.11 "Config protection" menu item**

In this menu, you can set a password for the configuration button in the service menu of the screen.

## 6.2.5. Web interface: System

### 6.2.5.1 Menu item "Info"

This page contains all important information about the device.

Option	Example	Explanation
Part name	B-Primis ET-Pi Prime 7	Product name of the device.
Device ID	S-01010503-0104- 00025	Combined product and serial number
Firmware version	1.5	Version of the firmware currently installed on the device.
Installed options / Licenses	(S502) DISPLAY ROTATION (S503) CONFIG PROTECTION	All licenses installed on the device. Some functions, such as display rotation, require additional licenses that may need to be installed.
System operation time	1612 hours 0 min	Total operating time of the device since it was first put into operation.
System Uptime	0 day 0 hour 19 min	Operating time of the device since the last start of the operating system.
CPU Temperature	Cur: 49.7°C, Ti- mestamp: 05/25/23 : 10:09:37	Displays the current, maximum, and minimum temperatures measured directly at the CPU.
Sensor Temperature	Cur: 50.1°C, Ti- mestamp: 05/25/23 : 11:00:51	Displays the current, maximum, and minimum temperatures measured inside the device housing.
Memory	total: 1860 MB available: 1536 MB	Total and available RAM memory of the device
Flash memory state	MLC: 20 - 30% de- vice lifetime used preEOL: normal (1, consumed less than 80% of reserved blocks)	Total number of complete write cycles on the available flash memory and information on the memory status

### 6.2.5.2 "Update" menu item

On this page, you can upload various files to the device to install firmware updates or additional licenses.

First, select the desired file (e.g., firmware\_et-pi\_x.x.x.tgz) using the "Browse..." button and upload it using the "Submit data" button. Depending on the size of the file and the quality of the connection, uploading the file may take several minutes. After uploading, the web interface displays a description and version of the uploaded file, which you can check. You can now start the update process by clicking the "Start" button; the update may take up to two minutes, depending on the size of the .tgz file.

 **CAUTION**

- ▶ Once an update has started, it cannot be interrupted. The power supply must not be disconnected from the device during an update process. Premature termination of an update will render the device in need of repair!
- 

 **NOTE**

- ▶ During the firmware update, the connection to the web interface may be interrupted.
  - ▶ In this case, try reloading the web browser. If a connection cannot be reestablished, watch the flashing sequence of the Run/Stop LEDs until they indicate a restart (2 flashes, 2-second pause).
- 

 **CAUTION**

- ▶ The device must be restarted after the update. No applications or user data on the control unit will be deleted during the update.
- 

**6.2.5.3 "Reboot" menu item**

The device can be restarted on this page. Some changes to the device settings require a subsequent restart.

## 6.2.6. Web interface: Diagnostics

### 6.2.6.1 "System Log" menu item

This page is divided into two sections:

- The "System Log" section displays the system log, which can be found in the file system under `/var/log/messages`. It contains general information about the operating system and the running services and programs. For example, accesses to the web interface by the `lighttpd` web server are recorded.
- The "System Diag" section records system interactions. Entries contain information about changes to the working memory, boot times, and power failures, for example.

### 6.2.6.2 "Ethernet" menu item

This page provides information about the device's network interfaces. Unlike the "Network" menu item, no settings can be made here. However, detailed information such as MAC address, set IP, received and sent packets, and data volumes is available.

### 6.2.6.3 "Storage" menu item

This page displays information about the device's storage status. The most important information for the user is the flash memory usage (marked in green here).

If one or more USB memory sticks are connected via a hub, these can be identified in the "Mounted on" column under the entry `/media/usbx` (marked orange here).

The x stands for the order of mounting (usually number 1 for a stick).

By plugging in a USB drive during operation, it is easy to check whether the USB drive is properly recognized and integrated by the system, which is important for functions such as USB updates.

### 6.2.6.4 "System Dump" menu item

On this page, you can create an image file of the entire diagnostic area of the device. This function is used to analyze the device in the event of a fault. It is recommended that you create the image file immediately after the fault occurs without restarting the device first. Creating the image file may take a few minutes. Once the file has been created, it will be offered for download by the browser. Save the file and send it to Berghof Support for analysis.

## 6.3. Operation

### 6.3.1. Status indicators

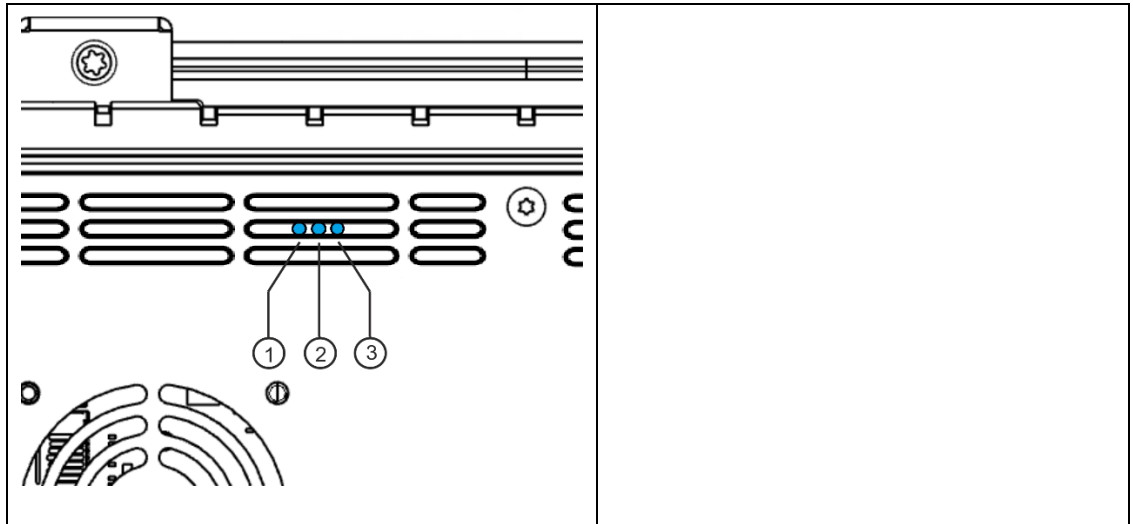

26 : Positions of the operating status LEDs

#### Status LEDs

Three operating status LEDs indicate the current status of the power supply, system, and error messages.

LED		Logical status
1	PWR (blue)	ON = correct supply voltage to the module electronics
2	Run/Stop	Indicates the system status
3	Error (red)	Indicates system error

#### RUN/STOP ERROR - LED signaling

There are 2 LEDs on the module for signaling the system status (RUN/STOP multicolor: red/green/yellow; ERROR single color red). The following system statuses are signaled via the LEDs:

System statuses	LED RUN/STOP	LED ERROR
Firmware, USB package update, or service mode active	Yellow flashing	Off
System error	Off	Red

Basic procedure for error stop:

- Determine the cause of the error (read out via web browser)
- Fix the cause of the error
- Reboot the device
- Restart the device

### 6.3.2. Real-time clock with voltage buffer

The ET-Pi series is equipped with a real-time clock. The buffer time is 30 days.

#### Set date/clock

The clock can be set via the web configuration.

### 6.3.3. Function button S1

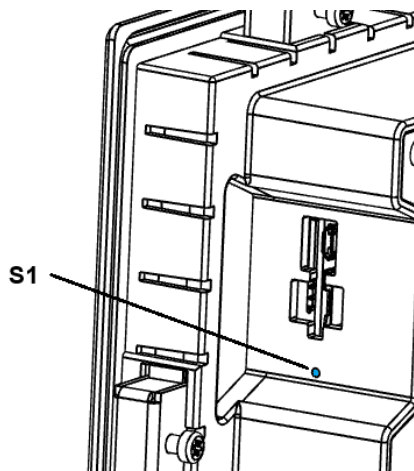

Fig. 27: Function button (S1)

Function button (S1)		
Operating status	Action	Command
Boot phase	Press and hold.	Boot in maintenance mode

The S1 button is located on the left side of the device.

To prevent accidental activation, the button can only be pressed with a pointed object (pen, screwdriver).

#### **Maintenance mode**

To enter maintenance mode, the device must be switched off. Then press and hold the button and switch the device back on. The button must be held down until the Run/Stop LED flashes yellow at 2-second intervals.

## 6.4. Troubleshooting

### 6.4.1. No network connection

- ▶ Check the wiring/plug.
- ▶ Check whether an IP address has been duplicated.
- ▶ Check the network settings on the PC: The settings for the subnet and subnet mask must match those of the device.
- ▶ Check the firewall and antivirus programs on the PC.
- ▶ Check the Lifeguard settings.

### 6.4.2. IP address unknown

If the IP address of the device is unknown, the device will display it on the screen when there is no connection. Alternatively, the device can also be reconfigured via a USB update.

5th Restart the device while holding down the S1 function button until the Run/Stop LED flashes yellow every 2 seconds.

The device is in maintenance mode and can be accessed via the factory-set IP address.

6th Access the device via the default IP address:

IP address: 169.254.255.XX

Netmask: 255.255.255.0

XX corresponds to the last 2 digits of the device's serial number. Exception: 00 becomes 100.

7th Adjust the network settings and make a note of them.

8. Restart the device.

Maintenance mode is automatically terminated.

The device is configured and ready for use.

## 7. Maintenance / Servicing

Repairs and maintenance may only be carried out by the manufacturer or authorized customer service.

### 7.1. Maintenance

#### **WARNING**

##### **Unregulated, unpredictable operation!**

Failure or malfunction can lead to unregulated and unpredictable operation.

- ▶ Do not plug in, connect, disconnect, or touch any connections during operation.
- ▶ Before working on the device, switch off all power supplies, including those of connected peripherals (externally powered encoders, programming devices, etc.).

---

The device is maintenance-free when used as intended.

- ▶ Ensure that all ventilation openings are unobstructed.
- ▶ Do not open the device. If work is necessary inside the device, contact service.

### 7.2. Cleaning

#### **NOTE**

##### **Damage to the front panel!**

The front panel is made of glass and must not be exposed to mechanical or chemical stress.

- ▶ Do not use high-pressure cleaners or steam jets.
  - ▶ Do not use corrosive cleaning agents, thinners, abrasives, or hard objects.
  - ▶ Do not apply excessive pressure to the front. Do not bend the device.
  - ▶ Do not place heavy, hard, or sharp objects on the device.
  - ▶ Do not disassemble the devices.
- 
- ▶ To prevent malfunctions due to accidental operation, switch off the device before cleaning the front panel.
  - ▶ Clean surfaces only with a dry, lint-free cloth.
  - ▶ Clean the display glass only with normal window cleaner or alcoholic solutions.

## 8. Disassembly

1. Disconnect the device and its peripheral devices from the power supply.
2. Disconnect all connectors and cables.

### NOTE

#### Damage to the device!

If you're not careful when taking it apart, the device could fall out of the mounting cutout or get damaged.

- ▶ Do not tilt the device.
- ▶ Secure the device against falling, especially when removing it from the mounting cutout.

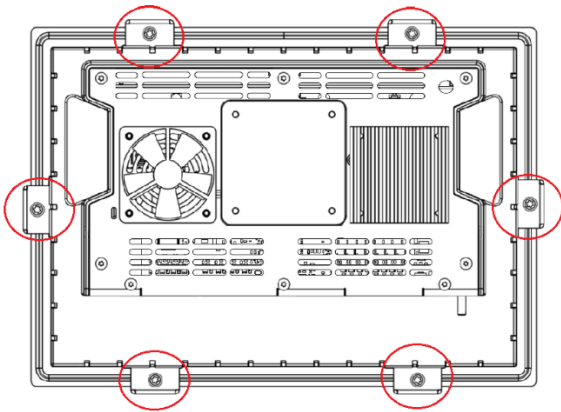

B-Primis ET-Pi Prime 7 / 10

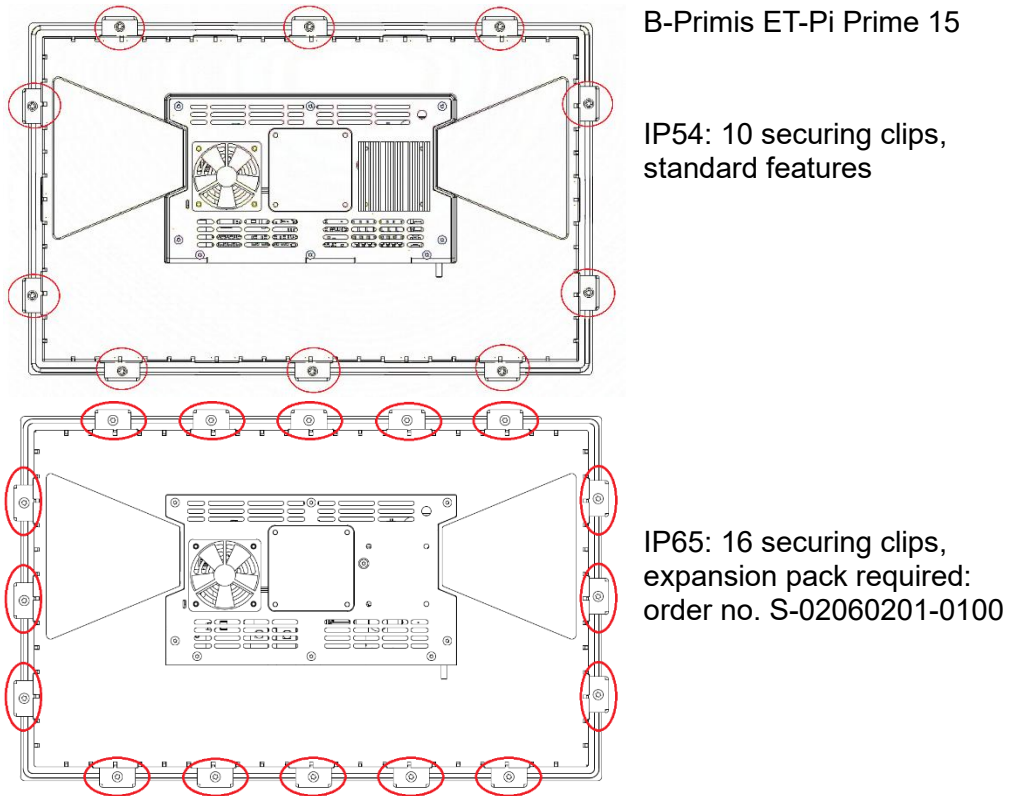

Fig. 28: Loosening screws

3. Loosen the screws on all securing clips evenly.  
ET-Pi Prime 7" / 10": 6x securing clip  
ET-Pi Prime 15": 10x securing clip for IP54 / 16x securing clip for IP65

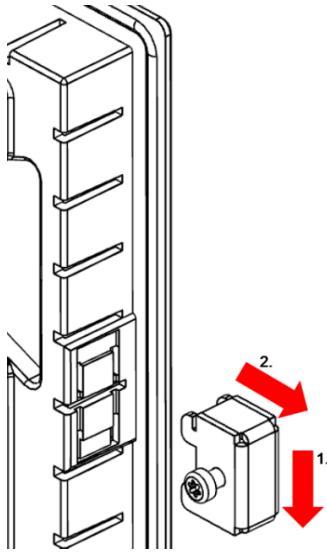

Fig. 29: Removing the securing clips

4. Removing the securing clips.

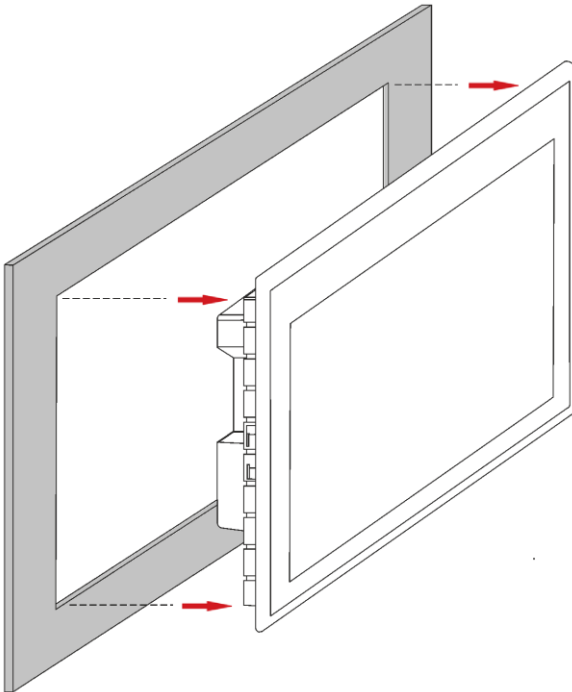

Fig.30 : Sliding the device out of the mounting cutout

5. Push the device evenly forward out of the mounting cutout.

## 9. Disposal

The device contains the following components, which must be disposed of separately:

- Metals
- Electronic components

The respective national regulations for the disposal of electrical appliances in B2B business apply.

The following options are available for disposing of the device:

### **Disposal by the manufacturer**

Unless otherwise agreed, the devices can be returned for disposal.

### **Disposal in accordance with regional regulations**

- ▶ Disassemble the device and completely dismantle it into its individual parts.
- ▶ Send metal parts for metal recycling.
- ▶ Sort electronic parts (circuit boards, drives, etc.).
- ▶ Dispose of electronic scrap in accordance with national regulations and laws.

## 10. Information and options

Ethernet Terminal	ET-Pi Prime 15	ET-Pi Prime 10	ET-Pi Prime 7
<b>Display</b>			
Display	Full HD	WXGA	WVGA
Display diagonal	15.6	10.1	7
Item no.	S-01010503-0108	S-01010503-0105	S-01010503-0104
Resolution	1920 x 1080 pixels	1280 x 800 pixels	800 x 480 pixels
Colors	TFT: 16.7 M (24 bits/pixel)		
Brightness	0–800 cd/m <sup>3</sup> adjustable		
<b>CPU, user memory</b>			
CPU	Raspberry Pi CM4 (1.5GHz quad core)		
Data storage (RAM/Flash)	1 GB RAM / 8 GB eMMC: scalable up to 8 GB RAM/ 32 GB eMMC with H-Option (H 500, H501,H502)		
<b>Dimensions and weight</b>			
Dimensions (WxHxD)	403.7 x 253.1 x 69.8 mm	262 x 186 x 69.3 mm	207.5 x 146.5 x 69.3 mm
Weight	2.18 kg	1.04 kg	0.82 kg
<b>Operating conditions</b>			
Ambient temperature	Front and rear of the device; in accordance with the installation instructions		
Operation			
Passively cooled	-10 °C to 55 °C	-10 °C to 60 °C	-10 °C to 60 °C
With fan	-10 °C to 60 °C	-10 °C to 65 °C	-10 °C to 65 °C
Relative humidity	max. 85%, non-condensing		
<b>Transport, storage</b>			
Ambient temperature	-20 °C to +70 °C		
Relative humidity	max. 85%, non-condensing		
<b>Operation</b>			
Installation	Control cabinet installation using securing clip Optional VESA mount		
Certifications	CE, UKCA, optionally available: UL, in preparation: FCC		
Touch operation	Capacitive, single touch		

Ethernet Terminal	ET-Pi Prime 15	ET-Pi Prime 10	ET-Pi Prime 7
Visualization	VNC client, web client (HTML5)		
Real-time clock	Yes, (buffer time > 30 days), accuracy +- 7ppm		
<b>Vibration resistance</b>			
Vibration	Sine wave (EN 60068-2-6) test: Fc 10...150 Hz, 1G (operation mode)		
Shock	15 G (approx. 150 m/s <sup>2</sup> ), 10 ms duration, half sine (EN 60068-2-27) Test: Ea		
<b>EMC, protection class</b>			
EMC Emission	EN IEC 61000-6-3:2022-06, residential area		
EMC Immunity	EN IEC 61000-6-2:2019-11, industrial area		
Protection class	III		
Insulation resistance	SELV (Ue < 30V) according to EN 61131-2; 500 VDC test voltage		
Protection category	Rear IP20 (not evaluated by UL), Front IP54 (not evaluated by UL) with 10 securing clips, Front IP65 (not evaluated by UL) with 16 securing clips	Rear IP20 (not evaluated by UL), Front IP65 (not evaluated by UL) 6 securing clips	Rear IP20 (not evaluated by UL), Front IP65 (not evaluated by UL) 6 securing clips
UL Enclosure Type	Type 1		
<b>Power supply (24 V power supply unit)</b>			
Supply voltage	+24 V DC (-15% / +20%) SELV max. AC voltage component 5%		
Current consumption	max. 1.2 A at +24 V DC	max. 0.55 A at +24 V DC	max. 0.25 A at +24 V DC
Reverse polarity protection	Integrated		
<b>Ethernet interface</b>			
Number/type of interface	1x 10/100/1000 Base T		
Connection technology	RJ45		
<b>USB interface</b>			
Number/type of interface	2x host USB 2.0 / USB connector type A		

Ethernet Terminal	ET-Pi Prime 15	ET-Pi Prime 10	ET-Pi Prime 7
Number of insertion and removal cycles	max. 1000		

---

## 10.1. Nameplate

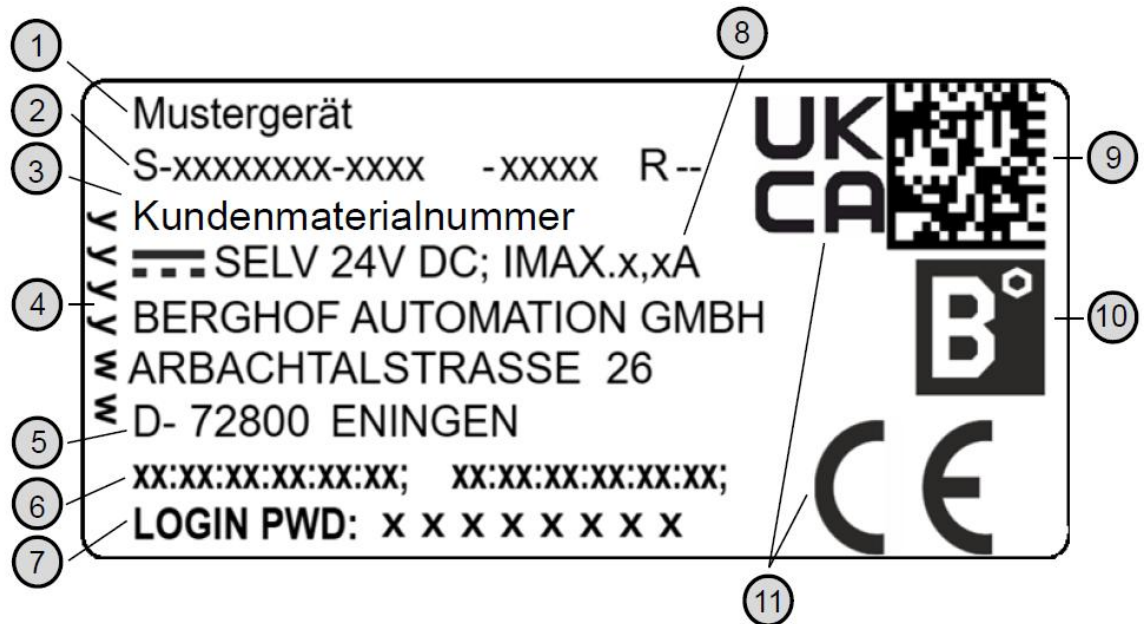

Fig. 31: Nameplate

Item	Designation	Item	Designation
1	Product name	7	Default password
2	Order no. / Serial no. / Revision	8	Supply voltage and maximum current
3	customer material number	9	QR code (identification no.)
4	Production date (year/week)	10	Manufacturer's logo
5	Manufacturer (manufacturer's address)	11	Conformity marking
6	MAC addresses of the device		

## 10.2. Device variants and identification

Designation	Order number
B-Primis ET-Pi Prime 7	S-01010503-0104
B-Primis ET-Pi Prime 10	S-01010503-0105
B-Primis ET-Pi Prime 15	S-01010503-0108

The following H-Options are available:

H003:	fan
H004:	vesa adapter
H300:	extended warranty 1 year
H301:	extended warranty 2 year
H500:	CM4 with 2GB RAM / 8 GB eMMC
H501:	CM4 with 4GB RAM / 32GB eMMC
H502:	CM4 with 8GB RAM/ 32 GB eMMC

## 10.3. Options and extensions

Options are ordered using the following format  
 "Order number Option1 Option2 ..."

e.g.: **S-01010503-0108 S001 S003 S004**

In addition to the order number, additional extensions in the form of hardware, software, and customer-specific options are identified as follows:

Option code	Option type
S000-S999	Software options e.g.: Display rotation
H000-H999	Hardware options e.g., plug set, certifications
C000-C999	Custom options e.g., customer-specific front panel

For more information about the options available for this device, please refer to the product catalog or website.

The additional features included or installed in the respective device are listed in the options label. This label can be found on the device and/or on the packaging.



Fig. 32: Option label

# 11. Standards and certificates

## 11.1. Standards

### Applied EU directives

- EMC Directive 2014/30/EU
- RoHS Directive 2011/65/EU (also 2015/863/EU)

### Applied EU standards

- Technical documentation for the assessment of electrical and electronic equipment with regard to the restriction of hazardous substances  
EN IEC 63000:2018
- Programmable logic controllers – Part 2: Equipment requirements and tests  
EN 61131-2:2007
- Electromagnetic compatibility (EMC) – Part 6-3: Generic standards – Emission standard for residential areas (IEC 61000-6-3: 2020)  
EN IEC 61000-6-3:2021
- Electromagnetic compatibility (EMC) – Part 6-2: Generic standards – Immunity for industrial environments (IEC 61000-6-2: 2016)  
EN IEC 61000-6-2:2019

### Applied UKCA directives

- EMC Directive of 2012  
UK S.I. 2016 No. 1091
- RoHS Directive 2016  
UK S.I. 2012 No. 3032

### Applied UKCA- Standards

- Technical documentation for assessing electrical and electronic equipment with regard to the restriction of hazardous substances  
BS EN IEC 63000:2018-12-10
- Programmable logic controllers - Operational requirements and tests  
BS EN 61131-2:2007
- Electromagnetic compatibility (EMC) - Part 6-3: Generic standards - Emission standard for residential environments  
BS EN IEC 61000-6-3:2021-03-30
- Electromagnetic compatibility (EMC) - Part 6-2: Generic standards - Immunity for industrial environments  
BS EN IEC 61000-6-2:2019-02-25

## 11.2. Declaration of conformity

The declarations of conformity, technical data, and further information can be found on our website at:  
<https://www.berghof-automation.com/downloads/>

Select the relevant section (automation technology) and fill out the form. Information on data protection can also be found on the page.

## 12. Customer service / Addresses

Repairs and maintenance work may only be carried out by the manufacturer or authorized customer service centers.

### 12.1. Customer service

Berghof Automation GmbH  
Arbachtalstrasse 26  
72800 Eningen  
Germany  
T  
E-mail: [support-controls@berghof.com](mailto:support-controls@berghof.com)  
[www.berghof-automation.com](http://www.berghof-automation.com)

### 12.2. Repair Service

Please send the goods for repair to the Berghof repair service, quoting the RMA number and providing a detailed description of the fault.

Berghof Automation GmbH  
BU Automation Technology  
Repair Service  
Arbachtalstrasse 26  
72800 Eningen

You can request the RMA number at:  
[www.berghof-reparaturservice.com](http://www.berghof-reparaturservice.com)

## 12.3. Addresses

DIN Media Verlag GmbH, 10787 Berlin

or

VDE-Verlag GmbH, 10625 Berlin

or

Search via the Internet: [www.iec.ch](http://www.iec.ch)

# 13. Appendix

## 13.1. Information on copyright and software license

The firmware of the devices contains free software. Parts of this software are subject to the following and other open source licenses:

- GNU General Public License (GPL)
- GNU Lesser General Public License (LGPL)
- Mozilla Public License (MPL)
- FreeType License (FTL)

The source code for the free software can be requested from Berghof customer service at cost price within three years of delivery of the device.

## 13.2. List of figures

1 : Overview of B-Primis ET-Pi Prime 7/10/15 (rear view) .....	15
Fig.2 : Dimensions ET-Pi Prime 7 .....	17
Fig.3 : Installation cutout ET-Pi Prime 7 .....	18
Fig.4 : Dimensions ET-Pi Prime 10 .....	19
5 : Mounting cutout ET-Pi Prime 10 .....	20
Fig.6 : Dimensions ET-Pi Prime 15 .....	21
Fig.7 : Mounting cutout ET-Pi Prime 15 .....	22
Fig.8 : Insertion into mounting cutout .....	23
Fig. 9 : Mounting the securing clips .....	24
Fig. 10 : Fully tightening the securing clips .....	25
Fig. 11: Power supply X1 .....	27
Fig. 12: Block diagram ET-Pi Prime .....	28
Fig. 13: Ethernet interface X3 .....	29
Fig.14 : USB interfaces X5 and X6 .....	30
Fig. 15: Home page with network settings .....	32
Fig. 16: Information page .....	32
Fig. 17: Network mode of the device .....	33
Fig. 18: Network settings of the device .....	33
Fig. 19: NTP settings of the device .....	33
Fig. 20: Setting the server IP .....	34
Fig. 21: Changing the Lifeguard setting .....	34
Fig. 22: Summary of network settings .....	34
23 : Switching to web terminal mode .....	35
Fig. 24: Setting the Visu URL .....	36
Fig. 25: Login window .....	37
26 : Positions of the operating status LEDs .....	46
Fig. 27: Function button (S1) .....	48
Fig. 28: Loosening screws .....	52
Fig. 29: Removing the securing clips .....	52
Fig.30 : Sliding the device out of the mounting cutout .....	53
Fig. 31: Nameplate .....	58
Fig. 32: Option label .....	60